

International Energy Agency

# IEA District Heating and Cooling

Programme of Research, Development and  
Demonstration on District Heating and Cooling

## GUIDELINE TO PLANNING AND BUILDING OF DISTRICT HEATING NETWORKS

Published by

**Novem**

*Netherlands agency for energy and the environment*



Acting as operating agent for  
the IEA District Heating and Cooling project

1996: N 3.1

**International Energy Agency**

Programme of Research, Development and Demonstration on District Heating

**Guideline to  
Planning and Building  
of District Heating Networks**

Dealing with the subject:

**GEF Ingenieurgesellschaft für Energietechnik und Fernwärme mbH  
Ferdinand-Porsche-Straße 4a, 69181 Leimen. Germany**

Leimen, May 31, 1995

## 1. Preface

### 1.1 The IEA-Project "District Heating and Cooling"

The International Energy Agency (IEA) was established in order to strengthen the cooperation between member countries. As one element of the International Energy Program, the participating countries undertake cooperative activities in energy research, development and demonstration.

District Heating and Cooling is seen by the IEA as a means by which countries may reduce their dependence on oil and improve their energy efficiency. It involves the increased use of indigenous or abundant fuels, the utilisation of waste energy and combined heat and power production.

IEA's "Programme of Research, Development and Demonstration on District Heating" was established at the end of 1983. Ten countries participated in the programme.

In May 1993 decisions were taken concerning an Annex IV, in which the participants will continue their cooperation for another three-year period. Items of the fourth phase are:

- (1) CHP/Cooling Guidelines
- (2) Advanced Transmission Fluids
- (3) Heat Distribution Technology
- (4) Network Supervision
- (5) Efficient Subutilities & Installations
- (6) Manual on District Heating Piping
- (7) Development of long term cooperation

General information about the IEA District Heating Project can be obtained from:

IEA Secretariat	Phone:	+33-1-45249975
Mrs. Gudrun Maass	Fax:	+33-1-45249988
2 Rue Andri-Pascal		
F - 75775 Paris Cedex 16, France		

or

NOVEM	
Netherlands Agency for Energy and the Environment	
Mr. F. van Bussel	Phone: +31-46-595332
P.O. Box 17	Fax: +31-46-528260

NL - 6130 AA Sittard, The Netherlands

NOVEM, The Netherlands is the Operating Agent for the programme since 1987. The Operating Agent operates the task under its supervision and responsibility.

## 1.2 The handbook: Planning and Building of District Heating Networks

District heating networks fulfill an important service role and construction of these calls for large-scale investment. Consequently, network systems must meet special criteria in terms of network operating life, reliability of supply and cost-effectiveness. A body of specialized knowledge has been assembled from the development of numerous heat and distribution services in northern and central Europe, some of them large, and this will be passed on here. Heating distribution systems of considerable size have also been built in Eastern Europe, albeit under different economic circumstances.

This handbook is intended for the trained engineer and contains information on particular aspects of building heat distribution lines. It is not a textbook for teaching the basics to engineers. It discusses only the fundamental aspects involved in design and construction but does not touch on specialized products or on specific construction alternatives.

This publication has been put together with the collaboration of experts from nearly ten countries. It is written in everyday engineering terms as well as those of routine planning for district heating systems. The text details many important situations and difficulties. This is not intended to intimidate the reader with the numerous interrelationships and problems but rather to make those less experienced aware of the hidden pitfalls.

Most of the manuscript was written in Germany. Correspondingly, the majority of the illustrated material has also been drawn from German sources. It should be said in this regard that cost considerations alone restricted the use of illustrated material from outside Germany. Scandinavian engineers have had no less success in developing the heat distribution systems in their own countries.

This work looks at the problems primarily from the standpoint of the engineer. The business background is discussed to the extent necessary for proper understanding. Even technically discussion is confined to the planning and construction of pipelines for hot water and not for steam. The issues involved in thermal generation or customer's service installations are touched on only as they affect network planning.

The present handbook is intended to provide engineers with stimulus for their everyday planning work. It will have achieved its purpose if it saves them from having to acquire some costly knowledge or other on their own.

As far as the organization of the contents is concerned, the handbook discusses the basic aspects required for network planning in the initial sections (up to and including Section 5). In Section 6 the reader is given a look at the technical and economic parameters which most affect network engineering. This is intended to provide a sufficient overview from which to recognize the most troublesome factors in the welter of interrelated aspects.

Section 7 deals with the process of network planning itself. The first general part discusses the various stages in the engineering aspects of planning while also describing the business situation and its implications on construction costs. Other technical discussions involve a detailed look at system hydraulics as well as issues relating to structural engineering, thermal insulation and even operating costs.

Lastly, Section 8 discusses pipeline engineering focussing on the laying of plastic-sheathed pipe. Other pipelaying techniques are discussed only as an adjunct. There is also discussion of special components involved in district heating lines such as compensators, inspection chambers, thermal insulation etc.

The case study in Section 9 is designed to illustrate the preceding theoretical sections. The handbook concludes with the requisite bibliographical data and editorial information.

## **2. Contents**

### **1. Foreword**

1.1 The IEA Project on District Heating and Cooling

1.2 The Handbook: Planning and Building of District Heating Networks

### **2. Contents**

### **3. General**

3.1 The Organization of a District Heating System

3.2 The Distribution of Thermal Energy

### **4. Demand for Thermal Energy**

4.1 Standard Load Duration Curve, Plant Utilization Period

4.2 Diurnal Variation, Annual Variation

4.3 Availability

4.4 Heat Density and Development Structure

### **5. Supplying Thermal Energy**

5.1 Generation of Heat

5.2 Separation of Base Load and Peak Load

5.3 Thermal Energy Storage

5.4 Network Loss

### **6. Principles of Network Design and Cost Factors**

6.1 Engineering

6.1.1 Minimum Operating Life

6.1.2 Outgoing Temperature

- 6.1.3 Regulation of Output
- 6.1.4 Pressure Control
- 6.2 Economic Viability
  - 6.2.1 The Cost Impact of Generation
  - 6.2. Energy Prices, Rates
  - 6.2.3 Network System Investment
  - 6.2.4 Cost Impact of the Operating Parameters
- 6.3 Network/Customer Interchange
- 6.4 Early Financial Problems in Developing A District Heating Service

## **7. Planning Heat Distribution Networks**

- 7.1 General Aspects
  - 7.1.1 Planning Stages
  - 7.1.2 Facility Size and Structure
  - 7.1.3 Project Management
- 7.2 Network Hydraulics
  - 7.2.1 Circulation
  - 7.2.2 Pressure Control
  - 7.2.3 Pump Design
  - 7.2.4 Booster Stations
- 7.3 Structural Aspects
  - 7.3.1 Design against Fatigue Failure
  - 7.3.2 Friction in Pipe Bearings
- 7.4 Economic Insulation Thickness

## **8. Pipeline Laying Methods**

### 8.1 Plastic Jacket Pipe

#### 8.1.1. Description, Function, Statics

#### 8.1.2 Range of Application

#### 8.1.3 Connection Technique

#### 8.1.4 System Monitoring and Leak Location

#### 8.1.5 Special Types of Plastic Jacket Pipe Systems

##### 8.1.5.1 Aquawarm

##### 8.1.5.2 Jacket Pipe Systems with Plastic Medium Pipes

### 8.2 Other Laying Methods

#### 8.2.1 Steel in Steel Pipes

#### 8.2.2 Above-Ground Lines

#### 8.2.3 Ducts

### 8.3 Special Components of District Heating Lines

#### 8.3.1 Pipe Restraint

#### 8.3.2 Compensation

#### 8.3.3 Valves

#### 8.3.4 Shafts

#### 8.3.5 Tracing Cable

### 8.4 Thermal Insulation

### 8.5 Tests, Commissioning

## **9. Typical Sequence for Implementing Construction Work associated with a District Heating Project**

### 9.1 Planning

### 9.2 Permits and Approvals



9.3 Preparing the Contract Award

9.4 General and Specific Contractual Conditions

9.5 Liability

9.6 Warranty

9.7 Project Manager

**10. Literature**

10.1 Books, reports, publications

10.2 Periodicals

10.3 Standards, Guidelines

**11. Editorial Staff, Participants, Acknowledgements**

### **3. General**

District heating networks provide private and public consumers with heat from a central generating facility. Businesses and industrial concerns may also be supplied at appropriate temperature levels. Heat is mostly produced in heat-and-power utilities with their effective fuel utilization. Waste heat from the incineration of garbage and industrial plants is also supplied to district heating networks. The heat component needed to meet peak-load requirements is obtained from heating plants.

A major problem for heat distribution services is the need to keep the entire system available for maximum heat output which is only required on very cold winter days. The rest of the time only a much lower output of heat is required, down to as little as roughly one-tenth during the summer.

#### **3.1 The Organization of a District Heating System**

A district heating system includes facilities for heat generation, heat distribution and customer service (cf. Fig. 3.1-1). Accordingly the present text deals with all parts of the heat distribution system found between the heat-and-power utility and the heating utility on the one hand and the customer service installations on the other. Hence, in the case of generating facilities located outside the area being served, heat distribution involves the transporting of heat to the utilities network, transfer from the transporting system to the distribution system, all trunk lines, utilities lines and the customer service lines. Heat distribution also involves pressure control, provision for expansion and water circulation, even when these may be contained wholly or in part in the heat-and-power utility or the heating utility.

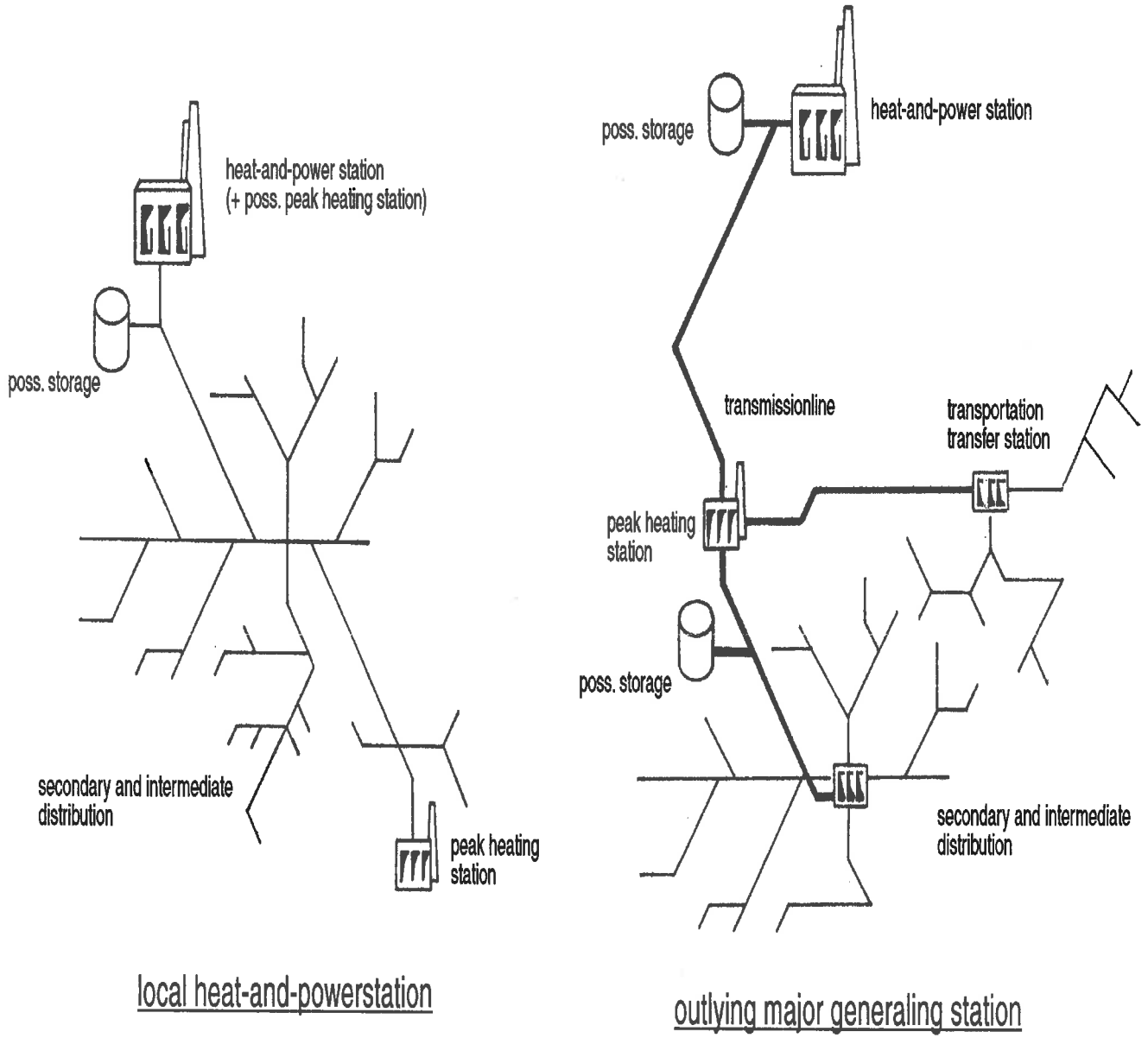

Fig. 3.1 - 1 Schematic organization of district heating systems

Today water is used as the heat carrier in district heating networks. In addition to technical operating advantages, water distribution systems as opposed to steam are able to operate with heating-water temperatures below 100°C which is more economical in energy terms. This handbook confines itself to description of modern systems and hence to heat distribution using water.

The large-scale distribution of heat had its beginnings around the turn of the century. Today, for energy-policy and environmental reasons, increased use of heat distribution systems is of great public interest. Due to the variety of ways they evolve, i.e. the time at which they are built, the geographic circumstances and the available thermal generating facilities, individual distribution networks may differ widely in their design. They differ in peak temperatures, operating techniques, operating pressures, customer servicing, hydraulic systems and in the engineering of the pipelines involved. There are heat distribution systems at every output level. The largest European facilities (Eastern Europe excluded) produce heat outputs of as much as 2000 MW and serve several hundred thousand households.

### 3.2 The Distribution of Thermal Energy

Heat distribution networks are built to connect residences with central heating systems to common thermal generating facilities. The supply and return temperatures encountered in domestic installations are usually 90°C and 70°C (or 80/60°C) for older systems and tend towards 70/40°C (or 60/40°C) for new systems. On the pressure side, domestic installations are designed up to 6 bar.

New district heating networks are set up to operate with hot water and are designed as two-line systems incorporating separate supply and return lines. District heating networks also include auxiliary systems such as pumping utilities, inspection chamber structures, pipe bridges and sag pipes.

Should the thermal generating facility not be located in the area where the heat is used, lengthy transmission lines are necessary.

These have a significant impact on the economic viability of a district heating system.

Customer systems are either serviced directly to allow hot water to flow directly through the domestic installation or indirectly via heat exchangers. In the case of direct service especially it is important to assure that the rated pressure in the residential system is not exceeded under any circumstances. Hot water is provided via heat exchanger. Fig. 3.2-1 shows examples of service installation layouts for direct and indirect customer service.

Service installations may involve considerable outlay in metering and regulating systems. These costs assume greater significance the smaller the consumption of the consumer. If distribution networks are operated at lower temperatures, the consumer utility can be reduced to the consumption meter, shut-off valve and sludge trap. This can produce considerable savings.

1.

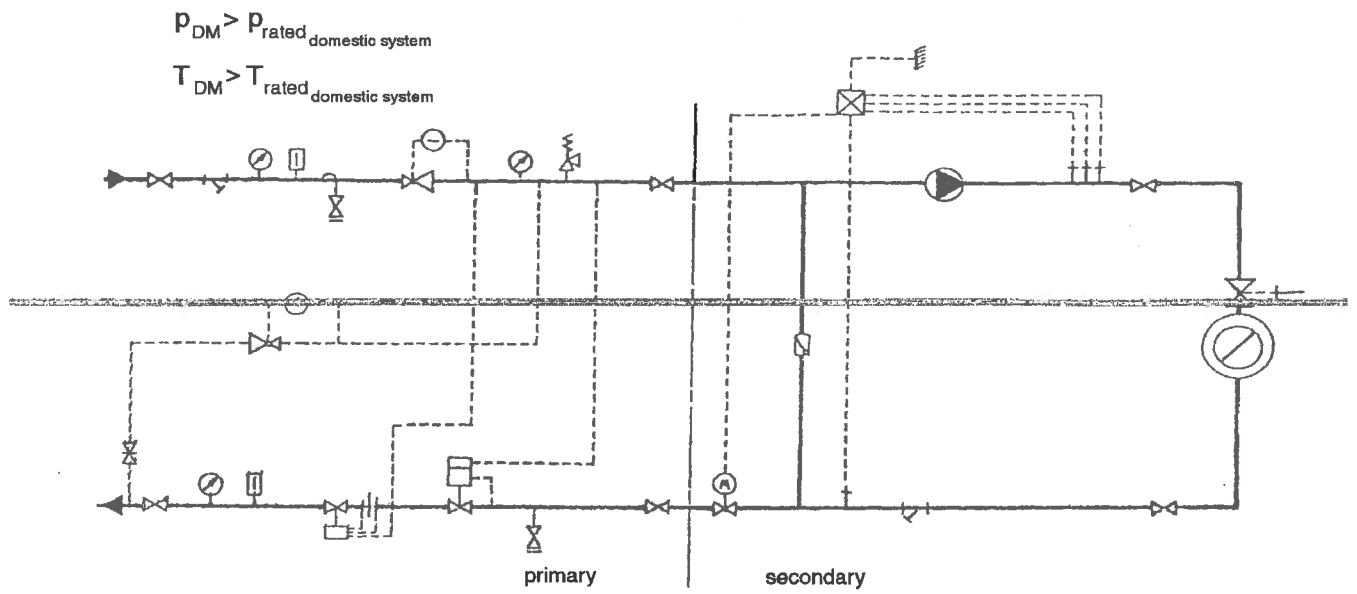

2.

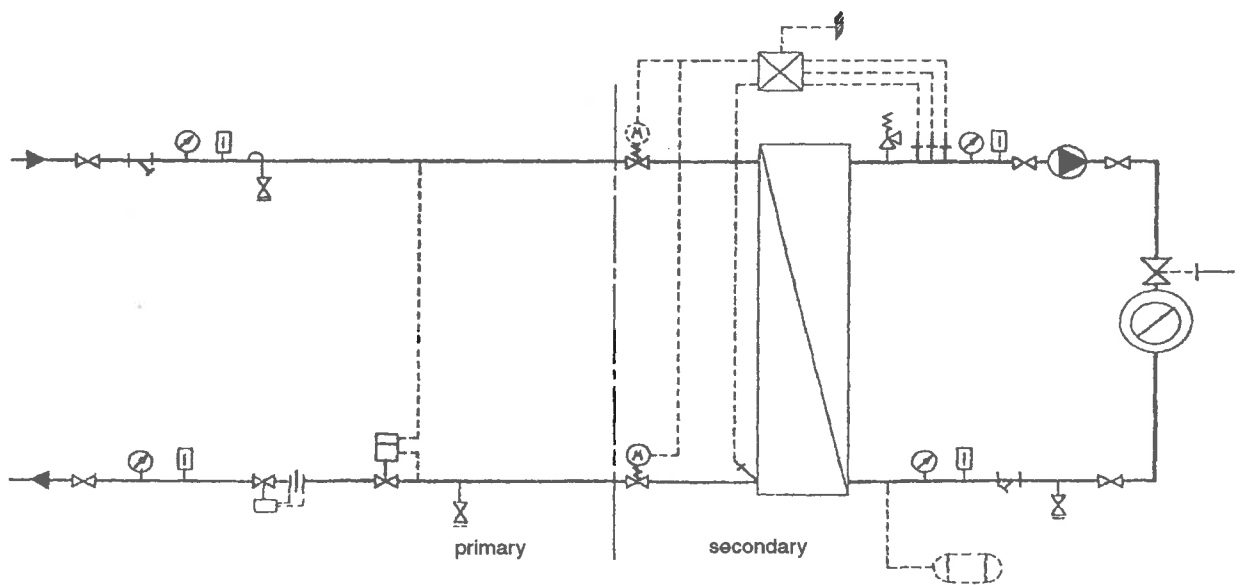

Fig. 3.2-1: Layouts for service installations

1. direct service
2. indirect service

## 4. Demand for Thermal Energy

The demand for thermal energy in a given service area consists of the energy demand for indoor heating, supply of hot water and industrial heating. The demand for indoor heat is determined by specific calculation for the subject being serviced. In practice, theoretical values for heat requirements are set liberally to assure that supply shortfalls do not occur.

The heat needed to provide hot water may be determined from the volume of hot water called for. It amounts to about 20% of the requirement for indoor heating. In the case of small-scale consumers the energy requirement for provision of hot water may considerably exceed that for indoor heating. In this case the distribution network situation may require provision of hot water in conjunction with storage. During summer operation the warming of water assures minimal consumption of heat.

Heat for industrial use is ordered under varying circumstances depending on the situation. Industrial heat is ordered selectively in the serviced area and often with only slight seasonal variations in energy requirement. Frequently it calls for separate pipelines.

The optimum output needed to supply a given area is considerably less than the theoretical sum of the energy requirements of all consumers. The discrepancy is accounted for by the fact that the various consumers do not require their peak energy at the same time and by the above mentioned departures from real energy requirements. To mathematically calculate the deviation a number of parameters and simplifications are used.

### 1. Load Condition

Load condition  $v$  is the quotient of peak heat output capacity and thermal energy requirement. It is calculated for individual customers, customer groups and for the entire area being serviced.

$$v = P_{\max} / P_{\text{req}}$$

Hence load condition is influenced by all uncertainties contained in the calculation of heat requirement. Load condition encompasses the reduced demand for peak output as a result of non-coincident consumption.

For the European countries, for example, the average value for load condition is  $v = 0.55$ . Fig. 4-1 shows the data for load condition for a major district heating network and an operating year in which optimum heat output was utilized.

## 2. Coincidence Factor

Coincidence factor is the quotient of simultaneous peak heat demand by a number of customers and the sum of the usually non-coincident individual peak demands for heat by these customers in the same period of time.

$$g = P_{\max} / \sum P_{\max i}$$

For service lines the coincidence factor can reach the value of 1; for all other lines it is below 1 and often near 0.5.

## 3. Alleviation Factor

To energy demand, which is an important figure in subscribing to a district heating network, there is applied an alleviation factor, e.g. 0.8.

## 4. Indoor Heating and Hot Water Supply

In practice, consumer's energy demand is usually derived solely from consumption for indoor heating. Of course, the method of providing hot water via the flow principle or in conjunction with storage facilities does have to be considered to avoid undesirable demand spikes.



In using one of the enumerated factors to determine peak demand for heat in a district heating system, the close interconnection with calculation of indoor heat requirements must always be kept in mind. If demand is calculated to within close tolerances as is the practice nowadays compared to older methods, the factors have to be set closer to 1. As much as possible every estimated value should be balanced by empirical values.

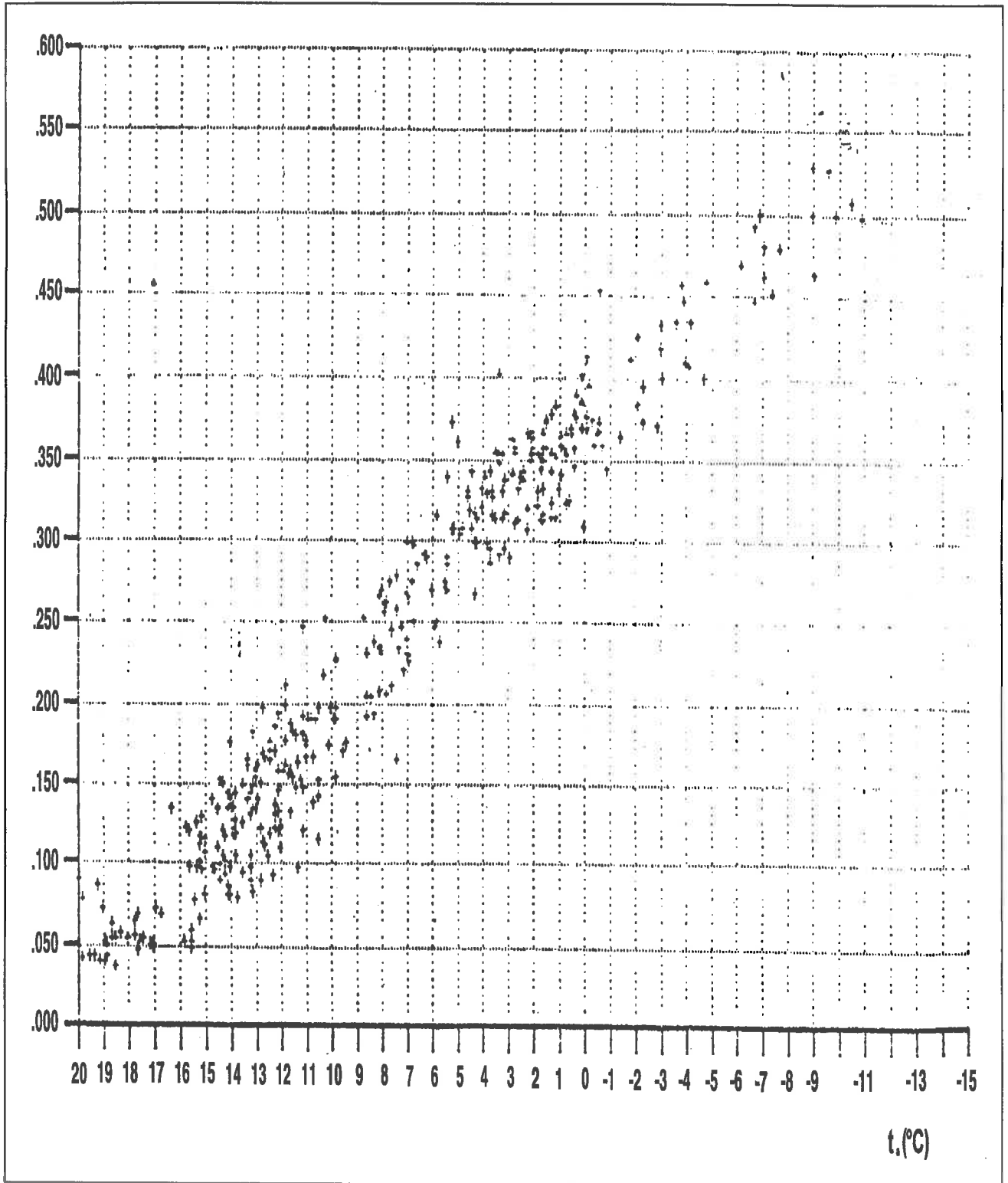

Fig. 4-1 Load condition of a major district heating network at various outdoor temperatures

#### 4.1 Standard Load Duration Curve, Plant Utilization Period

Demand for heat varies widely over the course of the calendar year. This may be shown in a variety of ways depending on whether we wish to show output against time, plot energy in a given period of time or tabulate the statistical data. An initial example is a diagram in which daily energy supplied is plotted chronologically for a year (Fig. 4.1-1). It can be seen from the figure that the energy is supplied from two generating utilities.

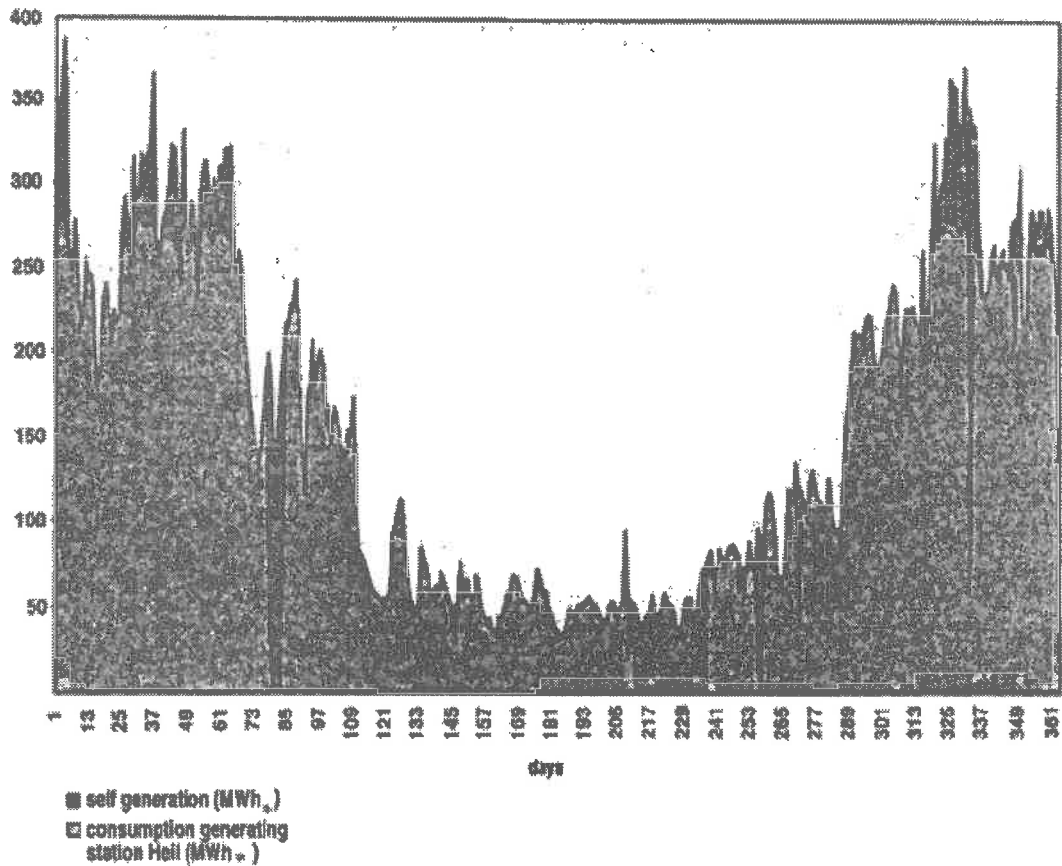

Fig. 4.1-1 Heat supplied from two generating utilities, chronologically

Widely used in energy management studies are diagrams which do not use chronological depiction but plot the variables in terms of their numerical value. If, for example, values for energy demand are plotted against the hours in the calendar year, the result is the annual load utilization curve, as shown by curve 1 in Fig. 4.1-2. Customary practice is to show it without dimensions, i.e. expressed in terms of maximum heat load. Also shown in this figure is a qualitative break-down of the energy demands for indoor heating, domestic water heating and industrial heat mentioned in the preceding section along with heat loss.

The shape of the annual load utilization curve is determined by climatic conditions, makeup of the consumer base and consumer behaviour. Important characteristics for economic analysis of utilization of the facilities and parts of them may be derived from the annual load utilization curve. Load utilization period is the quotient of annual energy output and maximum heat load.

The aim of an economically viable heat supply system must be to achieve large-scale supply of heat from the generating facilities. An important mechanism in this direction is reduction of load spikes.

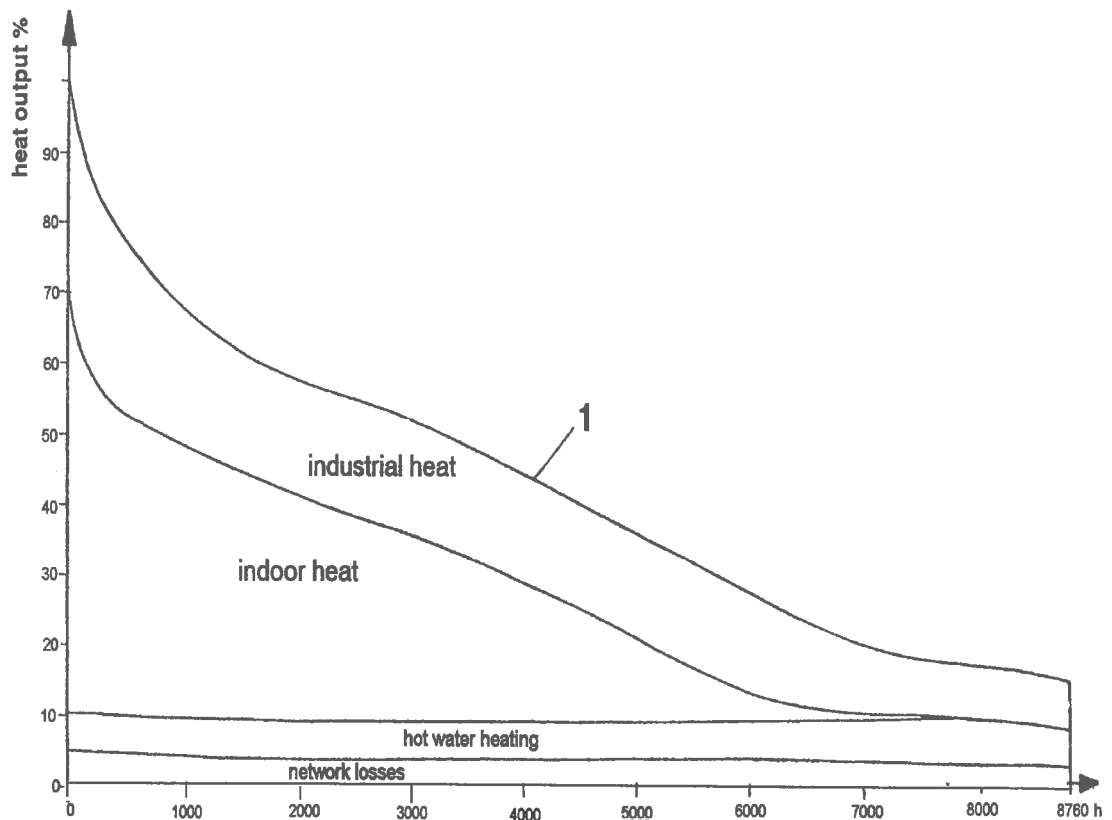

Fig. 4.1-2 Annual load utilization curve for a municipal heating system; schematic

Fig. 4.1-3 shows the load utilization curves of a number of suppliers for towns of medium and large size in the Federal Republic of Germany. Small towns show a similar curve shape. The diagrams are for various climatic situations and show varying consumer composition. By contrast, the geographic factors are eliminated in Fig. 4.1-4. This shows heating networks having varying consumer composition in the same city (cf. legend to figure).

In district heating networks, load utilization period based on maximum heat load is in the order of magnitude of 2500 to 3000 h/a for indoor heating and hot water supply. Load utilization period based on energy demand is around 1600 h/a. These values apply equally to Central Europe and Northern Europe although there are major differences in the design temperatures.

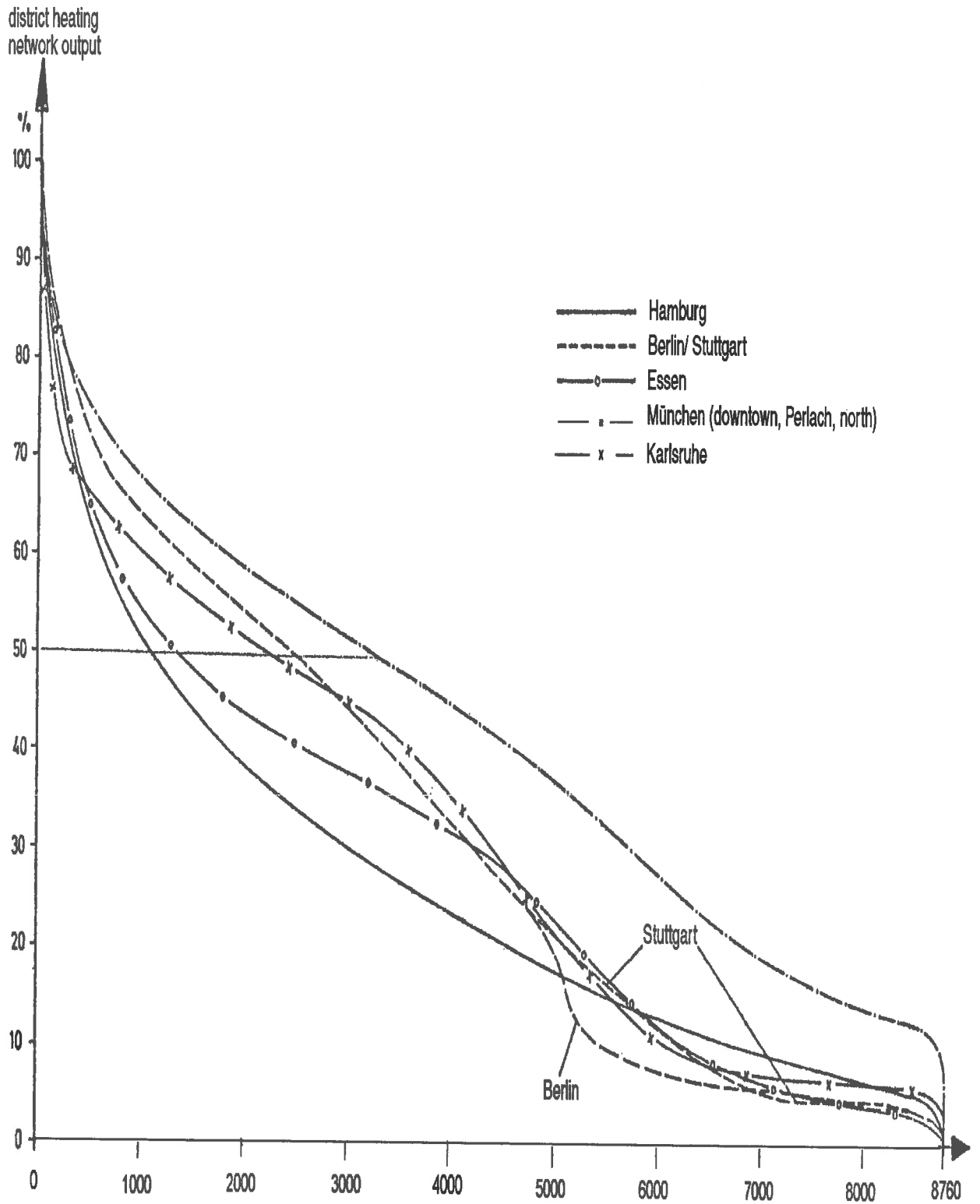

Fig. 4.1-3 Annual load utilization curves for various district heating network systems

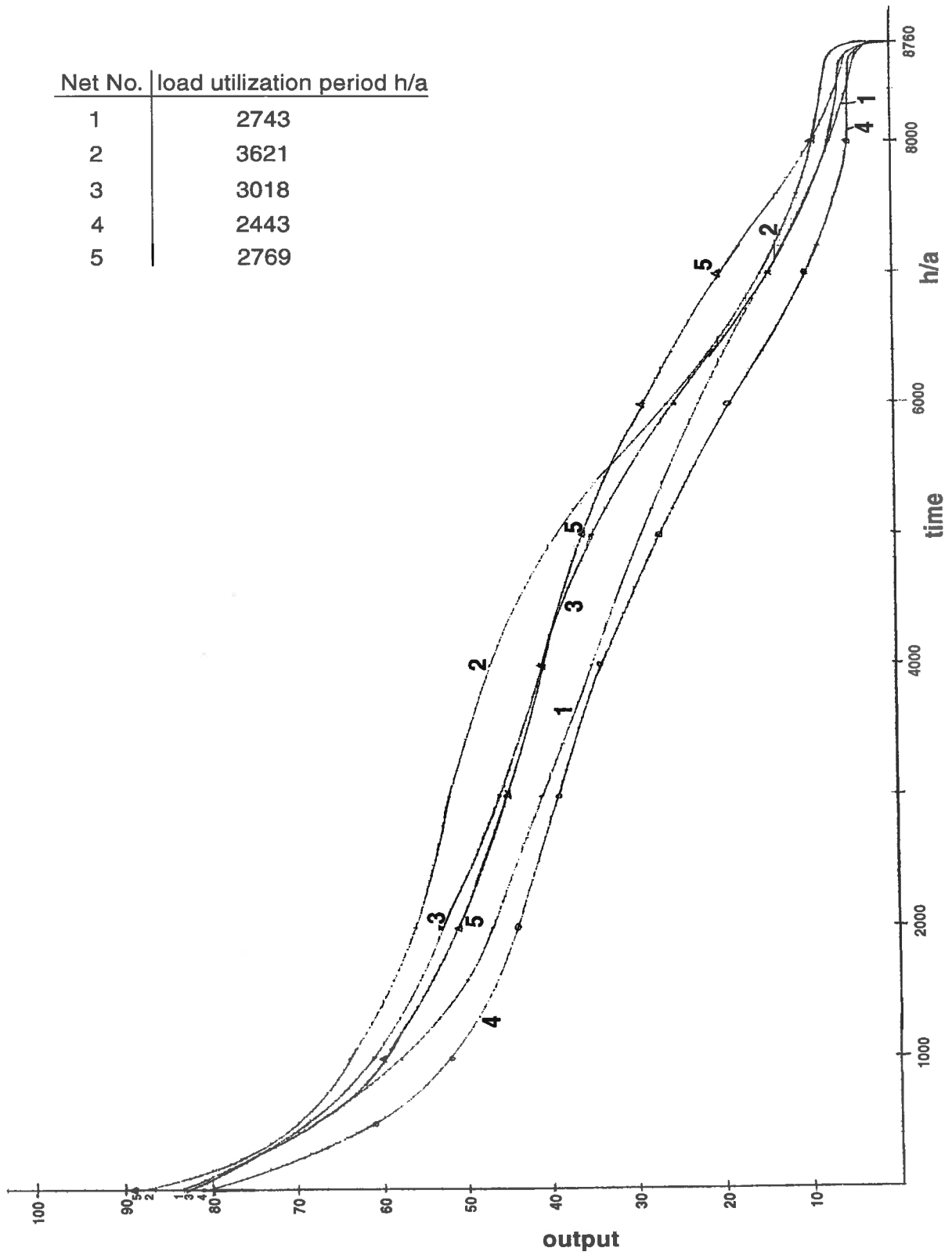

Fig. 4.1-4 Annual load utilization curve for similar climatic conditions but differing consumer structures, operating data

Standard values on utilization by various heat consumers relative to energy requirement are:

	utilization (h/yr)
single family dwelling, central operation	1700
multi-family dwelling	1800
office building	1700
hospital	1950
school, single storey	1450
school, two storey	1550
<hr/>	
air conditioned buildings	2000 to 3000

These values give only a rough idea.

#### 4.2 Diurnal Variation, Annual Variation

The demands made on central heat distribution systems vary from one time of day to another as illustrated in the diurnal variation curve (Fig. 4.2-1).

Because generation of heat is usually connected with the generation of power, the chart also shows diurnal variation in demand for power. Only use of heat storage makes it possible to move the two variation curves somewhat closer together. The variation curves for provision of heat in summer and winter differ markedly.



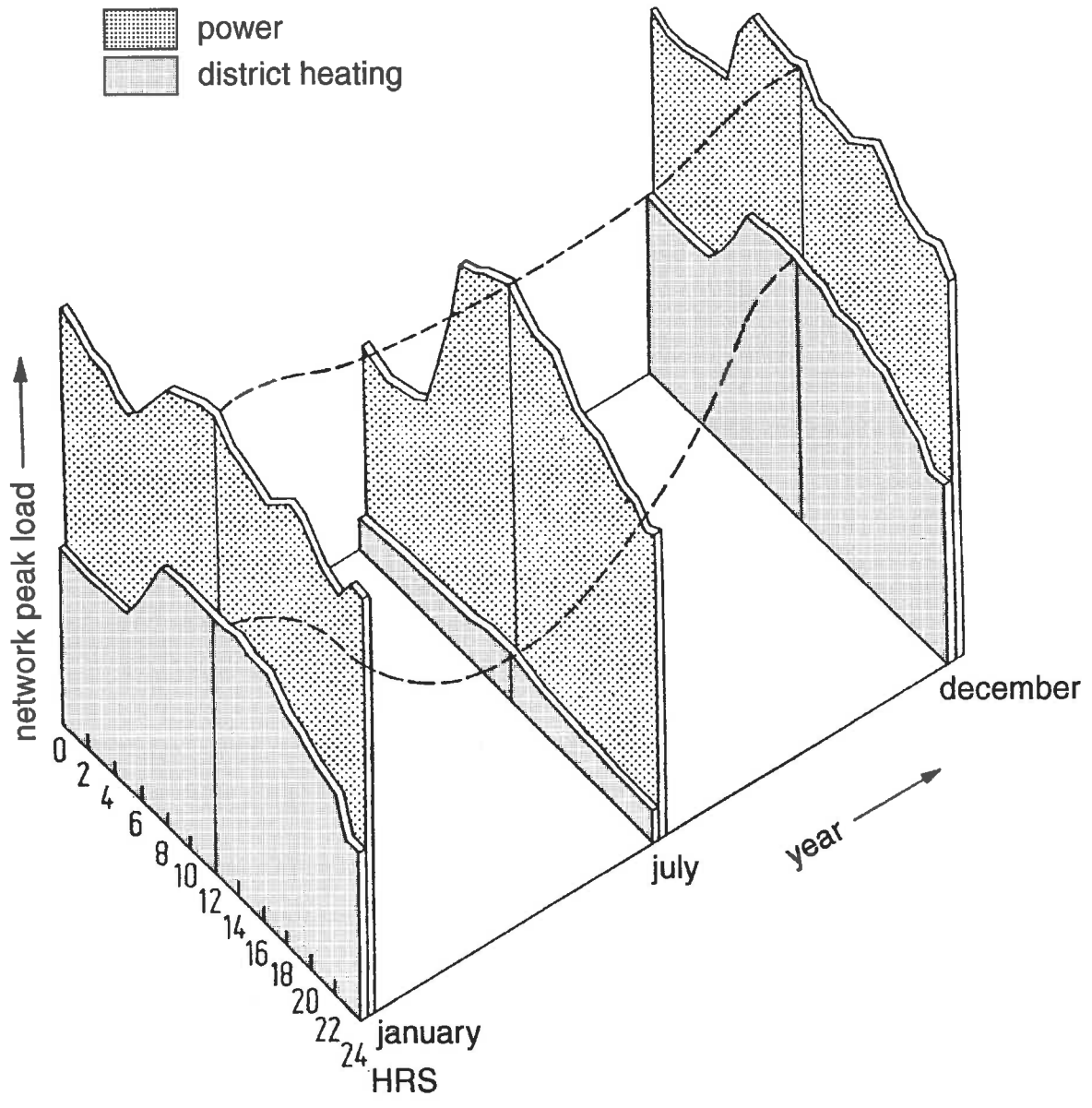

Fig. 4.2-1 Diurnal variation curves for the power and heat loads of a municipal utility over the course of a year

### 4.3 Availability

In the operation of district heating systems, disruptions are bound to occur. Because installations operate under only partial load except for a few hours a year, these disruptions can usually be readily managed.

In the case of generating facilities, provision is made for reserve output capacity; there being various approaches to apportioning reserve capacity, e.g:

- a reserve capacity of 20 % is installed, or
- in the event of breakdown of the largest generating unit, 100 % of maximum capacity (for Europe) must still be available or similar to this.

System design must also include provision for supply of the reserve capacity.

No provision is made for reserve transmission capacity in pipeline systems, 100% availability is assumed. Groups of pumps are arranged in such a way that in the event of breakdown in one pump, 100% circulation capacity will still be available.

District heating networks develop from service lines or from a fan-shaped network system. Large-scale network systems are sometimes linked together later to increase reliability of service.

Occasionally pipelines will suffer damage and have to be shut down. For problems of this nature, utilities must organize trouble-shooting teams. Disruption of operation can be limited to a few hours. Even on major lines, outages should be kept to five hours maximum.

In Finland, standards exist for maximum permissible outages. They are laid down according to type of consumer, time of day and outside temperature. The figures are shown in Tab. 4.3-1.

## Outdoor temperature (approximate)

-20°C

-5°C

	<i>hours</i> <i>07-16</i>	<i>hours</i> <i>16-21</i>	<i>hours</i> <i>21-07</i>	<i>hours</i> <i>07-16</i>	<i>hours</i> <i>16-21</i>	<i>hours</i> <i>21-07</i>
Nationally important building	1	3	5	3	5	5
Hospitals	3	3	5	3	3	5
Other asylum	3	3	5	3	3	8
Zoos, greenhouses	2	2	2	5	4	4
Important industry	2	2	3	3	5	5
Industry, offices	3	5	5	3	5	8
Apartment houses	7	5	7	8	5	10
Small houses	8	5	10	9	5	10

Table 4.3-1: Maximum Allowed Distribution Outages [9]

#### 4.4 Heat Density and Development Structure

It has already been pointed out in Section 4.1 that optimal utilization of installations is required over a large part of the operating year. To some extent this can be influenced by the makeup of the customer base. However because the greatest part of district heating goes to indoor heating, there are relatively narrow margins within which this factor can have an effect.

The heat requirements of an area depend greatly on the actual nature of local development. Industrial plants, hospitals, schools, major hotels, etc. usually have special consuming characteristics which have to be addressed in a specific manner. In residential areas there is a great variety in the types of buildings, with differing requirements for servicing as far as district heating is concerned. It is true in general that the higher the heat density in the service area, i.e. the higher the energy demand relative to the size of the area to be serviced, the more feasible the organization of a system. On the other hand it is not possible to quote a critical value for heat output density above which a district heating system is financially viable since there are still other factors affecting economic viability. These include potential revenues from the sale of heat and construction costs for pipelines.

There have been repeated efforts to categorize types of development. The most graphic of these may be the findings of a Swiss study [28], the recommendations of which are summarized in Fig. 4.4-1. It characterizes 11 types of development. Following is a brief discussion of which types of development present what circumstances for a district heating system.

Types 1 to 5 are not normally considered relevant to district energy systems. The most economic types are 6, 7 and 8. Types 9, 10 and 11 always require special handling.

Whether it is possible to extend heat distribution systems to include development types such as 1, 2 and 3 is viewed differently from country to country and even city to city. In Central Europe, it is thought that economically viable servicing with district heating does not extend beyond types 5 and 4 roughly. In Scandinavia, even type 3 and type 2 areas are readily serviced with district heating as well. In Finland, service is even extended to areas of scattered development of type 1.

The discussions presented here will illustrate that programs relating to energy management and energy policy which exist in various countries greatly affect the limitations of district heating. However, categorizing various types of development cannot serve as a substitute for analysis of economic viability. Day to day working with planning for district heating shows again and again that special circumstances can cause the limits of economic viability to shift sharply, e.g. if a potentially serviceable area is situated close to a trunk line or if construction of a distribution system can be readily carried out etc. A specific analysis of economic viability for a potential area of service is indispensable.

ST 1 patchwork				open, irregular development usually with small buildings, chiefly peripheral to cities and towns or in suburban areas, occasionally as strip-developed villages
ST 2 detached residential, newer				subdivisions of single-family dwellings on the peripheries of urban areas and in suburbs often with services laid out in tight geometric patterns, higher density than type 1
ST 3 village centre				high density development with small low buildings, villages in rural settings, also often concentrated along a village thoroughfare, in cities former village centres, frequently with original place name
ST 4 row-houses				row-house developments, almost always with concentrated geometrically laid-out provision of services, at edges of towns and cities and in suburban areas
ST 5 apartment buildings 3-5 storeys				mostly medium-sized apartment buildings, the individual buildings are larger than in types 1 to 4, relatively small spacing between buildings, services not so close together relatively speaking
ST 6 high-rise buildings				high-rises and large row-buildings characterized by broad spacing between buildings, service layout not tightly concentrated, and peripheral to urban areas (satellite towns)
ST 7 urban development, peripheral				urban multi-family dwellings, almost exclusively in large centres in areas bordering the downtown area, monolithic structures, enclosed inner areas regular grid layout of streets and roads
ST 8 downtown high density				downtown buildings from the turn of century, closely related to type 7, inner courtyards mostly built-up, very high density, in downtown area, often adjacent to old historic town-centre
ST 9 historic town-centre				town-centre from Middle Ages, fully built-up crooked streets, numerous churches
ST 10 large complexes				large separate complexes, unusual configurations mostly free-standing, often with signage (e.g. university medical centre), chiefly found in large urban centres
ST 11 industrial buildings				industrial and warehouse buildings, large often irregular configuration, usually readily accessible (rail, freeway, interchange, yards)

Fig. 4.4-1 Types of development

## 5. Supplying Thermal Energy

In the planning process and the operation of systems there are a great many terms relating to capacity in use, so that it is necessary here to start by defining the most important of these. Fig. 5-1 shows in schematic form how capacities in the areas of generation, distribution and consumption are used in the present text.

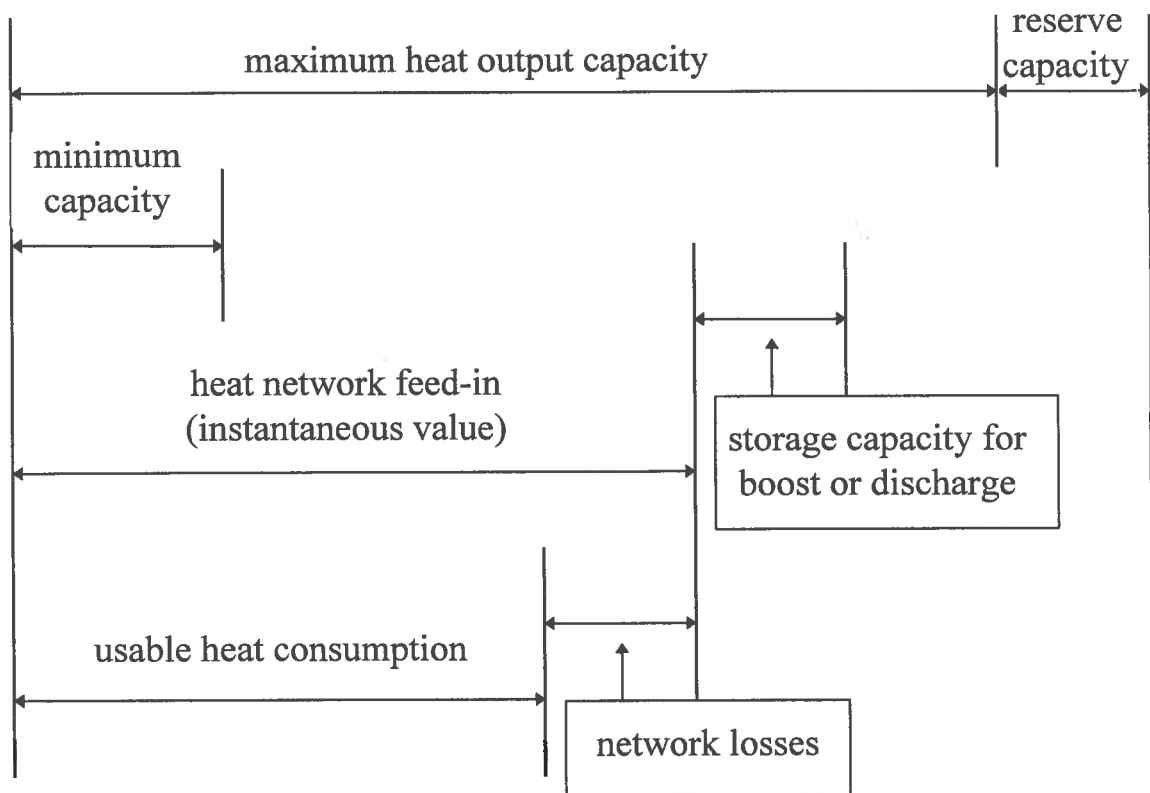

Fig. 5-1 Explanation of capacity-related terms

Moreover, in the district heating field definitions are necessary for:

- describing instantaneous values which change rapidly,
- taking into account the serviceability of units and components,
- describing either the demand or the supply side.

## 5.1 Generation of Heat

The principal facilities available for the generation of heat may be divided into three groups:

- combined heat-and-power utilities,
- heating plants, and
- industrial sources.

There are also special situations (geothermal energy, solar facilities, low temperature sources with heat pumps, etc.) which are very definitely of practical importance but which are not touched on here in the framework of a general discussion. The facilities at which heat is generated are not described here; simply their characteristics to the extent they have a bearing on the operation and economic viability of network systems.

Heat-and-power utilities simultaneously generate electricity and heat for large distribution systems. They may involve back-pressure or extraction condensing systems, gas turbines, engine-operated or gas and steam combination systems. These may be for a wide variety of output levels, characteristic power values (ratio of power-to-heat capacity) and fuels. The most commonly occurring types of heat-and-power utilities are mentioned in Fig. 5.1-1. Heat-and-power utilities require heavy capital investment, meaning that high utilization is vital for economically viable operation. The costs of thermal generation are mostly dependent on the supply temperature of the heat being distributed since higher temperature results in a high power loss in power-heat combination. Only in the open gas turbine and reciprocating engine are the heat costs independent of supply temperature since all heat is available at a high temperature level.

Heating plants are operated almost exclusively with oil or gas fuels. They require modest capital investment vis-a-vis heat-and- power utilities but involve high fuel costs. The preference therefore is to build heating plants to cover peak loading and for holding reserve capacity. Heat generation costs are independent of the supply temperature.

Industrial heat sources always have their idiosyncracies since they are connected with industrial production processes. Outgoing temperature can be limited to a narrow range, and the curve of network supply with time may show numerous irregularities. The daily



and weekly rhythm of supply may also be overshadowed by long-term economic influences. Often procurement of industrial waste heat is uncertain so that utilities have to hold reserves somewhere else. It has happened that waste heat has been supplied with such extreme energy fluctuations that storage heat has had to be cut in to offset dips in output. Idiosyncracies of this kind have to be taken into consideration when evaluating industrial waste heat.

Type of heat & power utility	fuel used	el. net. crit. output from .. to MW	dsitr. heat crit. output from power-heat combination from ... to MW	note
gas engine block heat & power utility	natural gas	0.05 ... 4.5	0.09 ... 8	three-way catalysts to maintain pollutant critical values
gas turbine heat & power utility with unfired hot water waste-heat boiler	natural gas fuel oil extra light	2 ... 60	3 ... 90	
gas and steam facility with unfired waste-heat boiler	natural gas fuel oil extra light	20 ... 300	23 ... 350	steam turbine type: back pressure system
gas and steam facility with unfired waste-heat boiler	natural gas fuel oil extra light	20 ... 330	20 ... 320	steam turbine type: bleeder condensing system
coal operated heat & power utility with fluidized bed combustion	soft coal	30 ... 100	42 ... 140	steam turbine type: bleeder condensing system
conventional coal operated heat & power utility	soft coal	100 ... 300	140 ... 420	coal dust fired boiler with added REA and DENOX system, steam turbine type: bleeder condensing system

Table 5.1-1 The most common types of heat-and-power utilities

## 5.2 Separation of Base Load and Peak Load

Demand for district heat output with time follows the annual load utilization curve already discussed. Peak load is only required for a few hours over the course of the year with the result that the system as a whole is usually operated at only partial load. Because of this the district heat business separates output into base load and peak load as do other parts of the utilities sector. Base load operates with a high degree of utilization, peak load with a low one: cf. Fig. 5.2-1. Minimal overall costs are incurred for separation of output by using, for generation of base load, facilities operating with lower fuel costs and higher capital investment. For peak load higher fuel costs may be accepted but the capital investment has to be low.

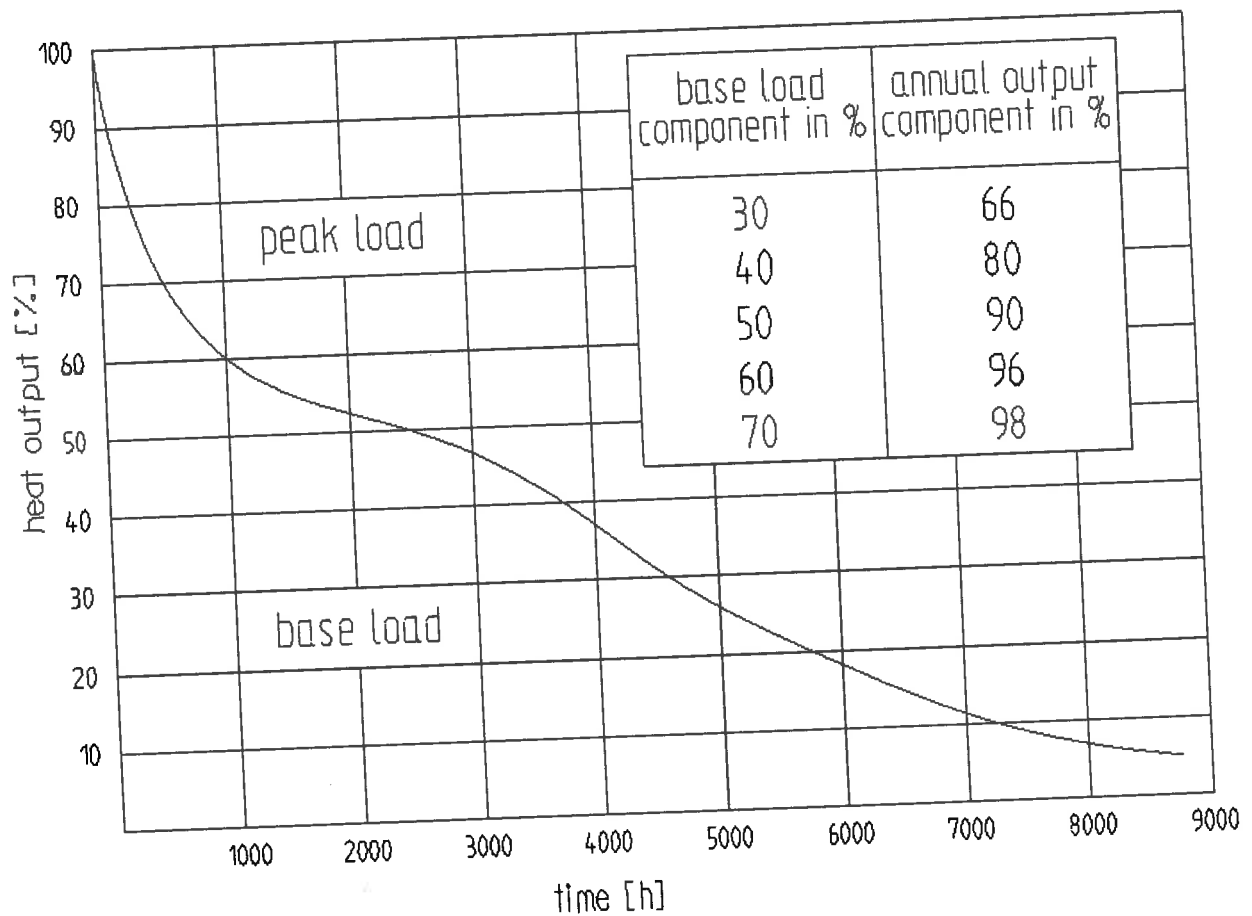

Fig. 5.2-1 Separation of output: base load vs peak load.

This fundamental relationship is shown in Fig. 5.2-1. The small sidebar shows how separation of output between two facilities can influence their proportion of annual energy generated. In practice the proportion of base load in the power-heat combination in the business of supplying district heat has tended to be from 30% to 50% of the peak load. From this results a proportion of energy between 66 and 90 % of annual energy. Proportions of base load more than 50 % are unusual. The lower value applies more for smaller systems, operating, for example, with an engine-driven heat-and-power utility.

An actual illustration of energy supply from a geothermal facility is shown in Fig. 5.2-2. Hot water for the distribution system is preheated by direct heat exchange with geothermal water, component 1. When heat demand increases, the first thing used is waste heat from an engine-driven block heat-and-power utility (component 2) before further generating capacity from heat pumps is brought on. Area 4 represents the component of the peak load boiler.

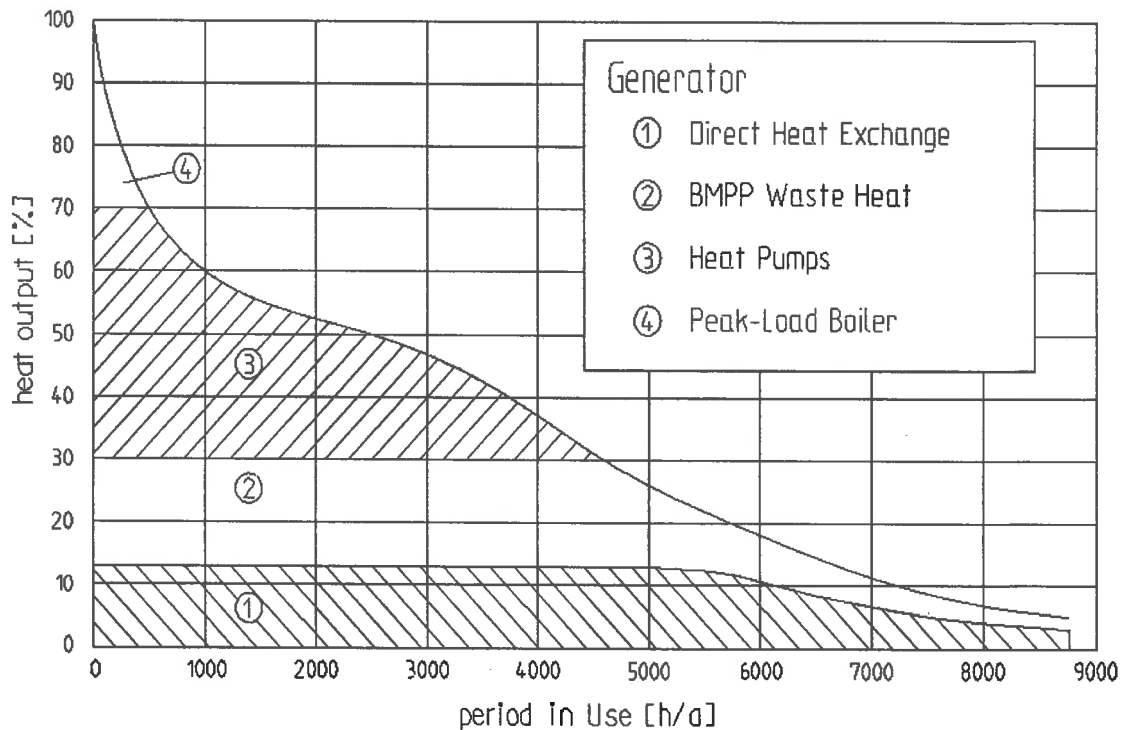

Fig 5.2-2 Composition of the heat energy in a geothermal facility

The separation of output initially described in principle is very closely regulated in major facilities and finely tuned according to the economic data of each individual plant. Big systems may contain thirty or more generating units. As an illustration Fig. 5.2-3 shows a daily operating plan for heat generation to serve the city of Hamburg. Of the existing generating facilities, only five are in operation on the day shown here.

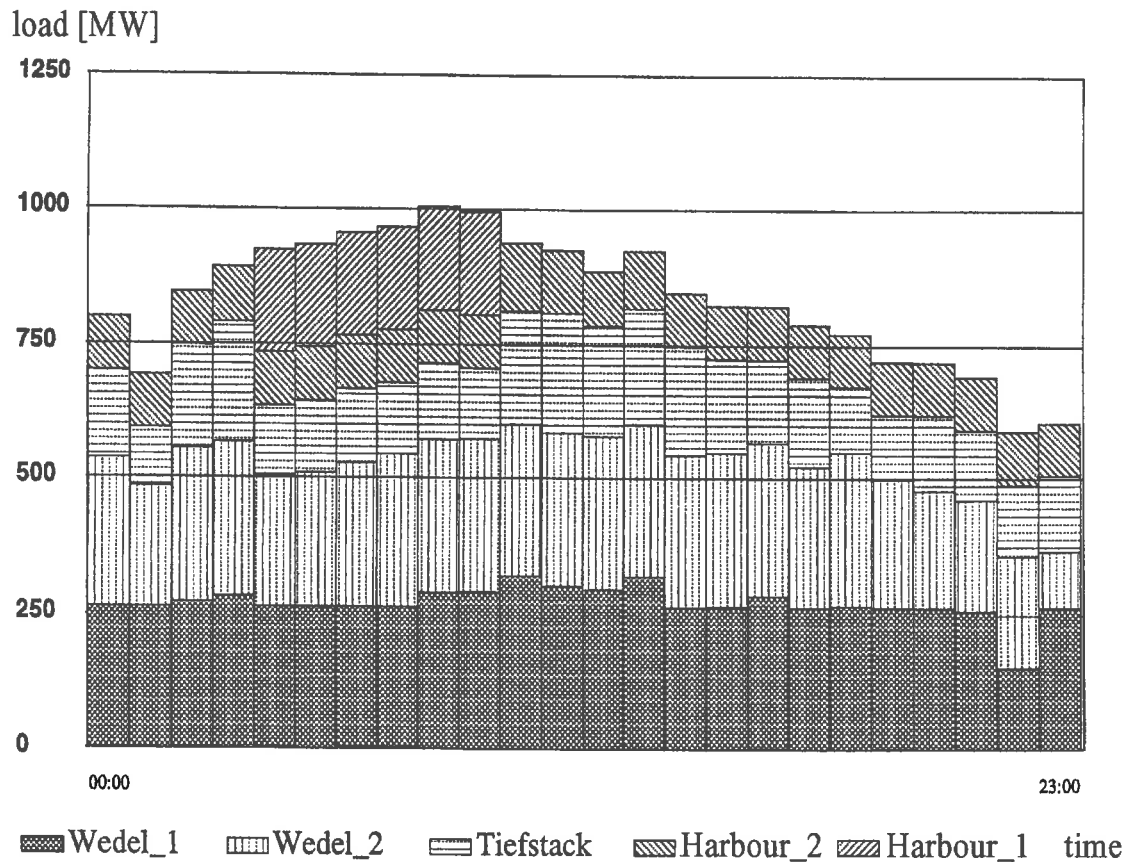

Fig. 5.2-3 Daily operating plan for district heat

Output separation plays a critical role in thermal generation in heat-and-power utilities and heating plants and is of great importance for heat transmission lines. If transmission lines are designed only for the base load component, good utilization can be achieved. Peak-load generation then has to be installed in the serviced area. However, secondary and intermediate distribution must always be designed for full peak output.

### **5.3 Thermal Energy Storage**

Aside from the storage of energy, heat storage facilities allow separation of load for power and heat in combined production or shifting of quantities of energy into different rate periods, e.g. day/night rates for power consumption.

The storage medium in heat storage facilities is water. In the main, storage tanks are built for operation at normal pressure and below 100°C. However, there are pressure-type reservoirs up to about 160°C which may be set up in a battery of as many as thirty cylindrical pressure tanks. Fig. 5.3-1 shows a non-pressurized reservoir tank and Fig. 5.3-2 a reservoir tank for up to 32 bar and 180/60°C.

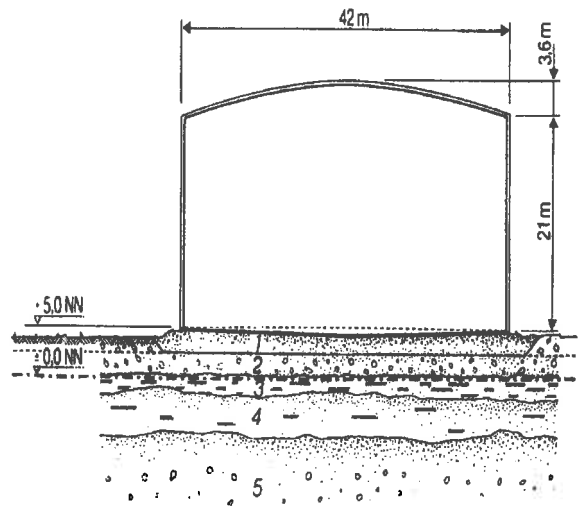
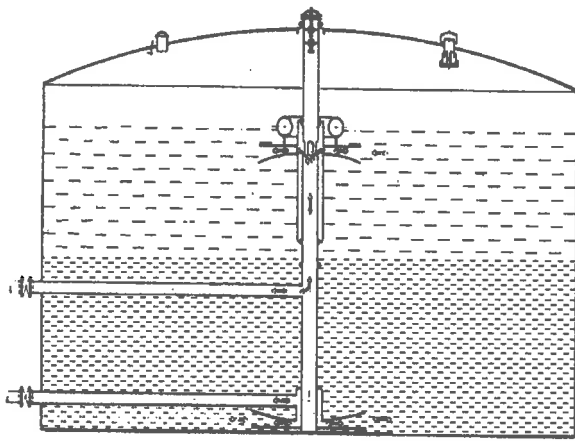
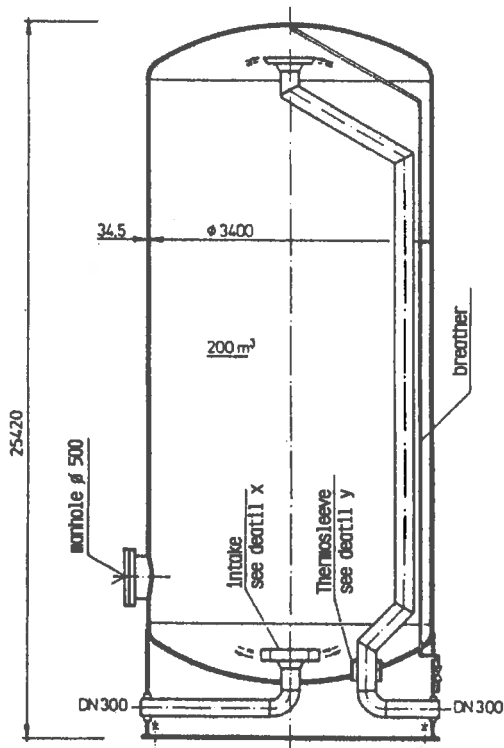
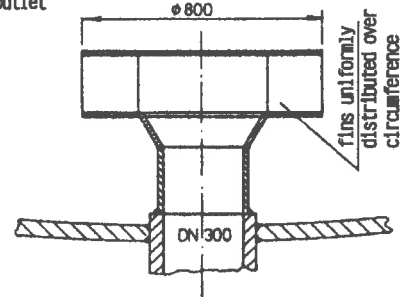

Fig. 5.3-1 Non-pressurized reservoir tanks



Detail X  
Intake/outlet



Detail Y  
Thermosleeve

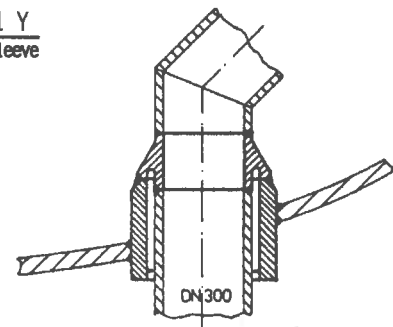

Fig. 5.3-2 Pressurized reservoir element for 32 bar and 180/60°C

The utilization and hence the economic viability of heat reservoirs is determined by the frequency of the charging cycles. Experience has shown that only reservoirs having several charging cycles per week are economically viable. Once in a while however reservoirs are built not for economic but for operating reasons.

For example, there may be a need to keep engine systems operating for certain minimum periods yet this may not be possible through network supply during periods of low demand. Reservoir tanks may also be used to store network supply water.

Efforts are also made for economic reasons to use the water circulated in the system for storage. This is made possible by raising the temperatures in the supply or return pipes. This storage technique differs for pipeline systems under DN 400 and distribution networks as opposed to major trunk lines. In distribution networks this practice has not proven effective in regular operation. Experienced operating personnel do indeed use this option on rare occasions but not as a regular practice. The volumes of heat which can be stored are small and storage has undesirable side-effects for operation: the raising of supply temperature produces a steady decline in throughflow since the volume regulators of the suppliers service installations are activated one after the other.

More promising is heat storage in major pipeline systems over roughly DN 400 since these lines hold relatively large volumes of water. Even here there are operating problems although it seems they may be managed using central process control engineering. Developments in this area are proceeding, although as far as their present status is concerned it has to be said that network storage still does not contribute significantly to the economic viability of the system as a whole.

#### **5.4 Network Loss**

Network loss is defined as the difference between the annual volume of heat put into a district heating network and the annual volume of heat delivered to all of the consuming parties. In engineering practice for modern district heating networks using composite plastic-sheathed pipe, losses are assumed to be 6 to 8% of input. Older network systems often show higher loss since they were designed on the basis of earlier energy costs and are poorly insulated. Heat loss is in the area of 3% in winter at peak output and perhaps around 20% in the summer when the entire system is kept in operation solely to supply hot water.



Heat loss as a proportion of network input represents a rough definition. A proper view in terms of physics would take into account the energy added by water circulation involving pump energy in the form of heat of friction being added to the water of the network system. According to the law of cooling, the magnitude of heat loss is proportional to the difference between the supply temperature and the ambient temperature.

In actual practice, heat losses are only recorded statistically on the basis of system input and heat billed at the customer end. It is interesting to notice that, in comparison to electricity, transmission losses for district heating are not greatly different from those of power transmission losses - about 5%.

For trunk lines it is mandatory that thickness of insulation be given special consideration. In this regard, cost and benefit have to be balanced against one another. For more on this aspect, cf. Section 7.4.2.

But heat loss means not only energy loss but loss of temperature as well. At peak load, temperature loss from generation to final consumer has been shown to be markedly under 5 K. This drop may however increase considerably at low output and adverse flow conditions. Should supply problems be anticipated for individual consumers, this may be specifically addressed by installing a bypass, possibly thermostatically controlled. However, bypasses are not desirable from an energy management standpoint.

## 6. Principles of Network Design and Cost Factors

The planning of a district heat distribution system is an interactive process involving engineering studies, business forecasts and the construction work itself. Engineering design, actual construction and economic viability are mutually interrelated. Design is a process of closely-interrelated optimization.

Discussed in this section to begin with are the most important design principles, followed by explanation of economic aspects.

Because the relationships are more readily appreciated once their economic background is understood, following is a rough idea of the cost structure involved in district heating.

Supplying buildings with heat involves costs on the part of the heat utilities as well as costs on the part of the building owner for installation and operation of his facilities. The boundary of property of the heat utility and therefore the boundary of costs to the building owner depends from the special heat utility and differs from country to country. The individual cost components are shown as orders of magnitude in Fig. 6-1 as an example for a standard case involving long-distance heat transmission. The figure shows the separation of total costs in components of investment costs, operating costs and heat generation costs. It can be seen, that investment costs are the most important cost component (s. also figure 6.2-1).

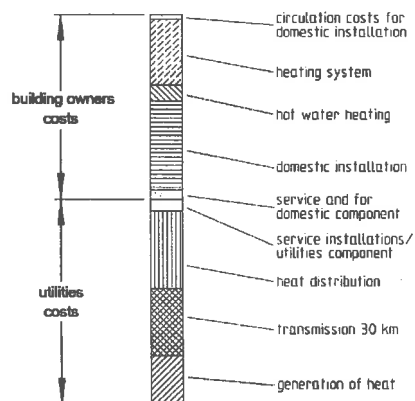

Fig. 6-1 The cost structure of district heating - shown are cost components for the district heating system and the domestic system

In present-day district heating utilities, the key cost components are in heat distribution and heat generation. Heat transmission systems are built within the bounds of economic resources; in Denmark over distances of up to about 50 km. Heat distribution costs frequently account for something in the area of 60% of total costs.

## 6.1 Engineering

The design of district heating systems calls for extensive experience in the field and is carried out either by consultants independent of the producers or by the utility and/or suppliers also. It is usually not difficult to set up a system to operate properly but it does require special expertise to:

- set up an economically optimized system which meets the numerous technical and economic criteria,
- assure the requisite operating safety, and
- provide long operating life with low maintenance.

It is desirable that there be continuous exchange of information among planners, construction supervisors and operating personnel.

### 6.1.1 Minimum Operating Life

The terms *operating life* and *depreciation period* are used to describe the life span of district heating systems. Operating life refers to physical life span whereas depreciation period relates to the business and tax aspects of operation. The two are defined separately from one another and are important because of the high value of distribution facilities.

The operating life of a district heating system is the time during which the facility is maintained in an operating state. Should the cost of maintaining a line as it ages exceed the annual costs of a new line, the old line has reached the end of its physical operating life and is replaced. Of course a line may reach the end of its operating life for reasons relating to reliability of supply or operating safety.

By contrast, depreciation period is a unit of time defined in terms of business considerations. It sets out the period of time over which the system may be depreciated for wear and tear for such things as tax purposes. No further investigation of depreciation is given here since this depends largely on individual approaches.

The annual expenditures for a system or network, especially the costs of servicing the capital investment, represent a major cost element for a utility. Servicing costs, which naturally depend on the size of the capital investment involved, are also dependent on interest rates and physical operating life. Following are some explanatory remarks from an annuity perspective. If, at a constant interest rate of, say 8% as in the example, annuities are plotted as a function of operating life, the result is a curve as shown in Fig. 6.1.1-1 (annual annuities, supplementary). In the short term, the annual costs are very high but these drop over a lengthy operating life of about 50 years to values in the order of magnitude of the interest rate. This situation shows why minimum operating life values of about thirty years are necessary for district heating lines. On the other hand it also indicates that it makes no sense to demand much higher operating life for district heating lines, especially if this would increase construction costs.

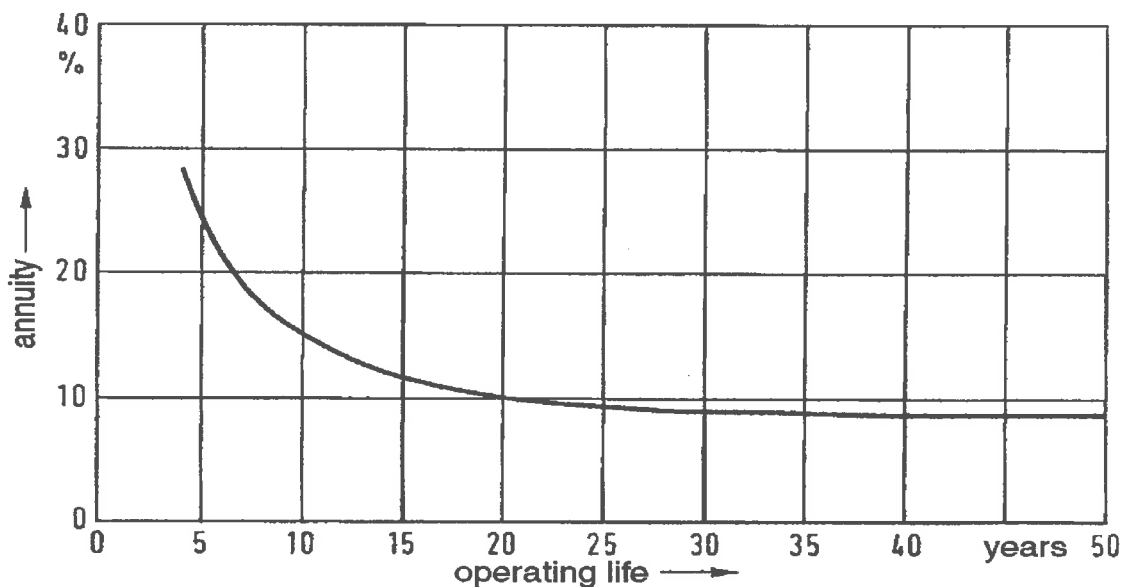

Fig. 6.1.1-1 Annual supplementary annuities of an investment as a function of operating life, rate of interest 8%

The graph also illustrates the considerable losses an investor can suffer when his district heating network does not last for the projected operating life. If operation lasts only a short time, the annual costs increase drastically.

Figures for operating life customarily used by the utilities are shown in Table 6.1.1-1.

Table 6.1.1-1 Table of common operating-life figures for district heating lines

Pipeline system	Utility-specified operating life in years
1. Plastic-sheathed pipe	20 to 40
2. Above-ground	20 to 50
3. Trenched lines	20 to 50
4. Steel-in-steel pipe	20 to 40
5. Condensate pipework	20 to 30

The operating life specified in this instance is high compared to other industrial installations. This means especially high criteria for the planning and construction of the systems, but also as far as builders' guarantees are concerned. These guarantees usually cover two years. Frequently supply contracts will extend the period to five years for district heating components. Occasionally a ten year guarantee will even be negotiated. In all cases a considerable gap looms between guarantee and required minimum life span in which lies the investment risk of the utilities.

The suppliers are therefore obliged to plan carefully and must be mindful of producing high quality construction. Careful planning means reliance on practices which have proven themselves over the long-term, accepting only proven low-maintenance components, using

only reliable characteristic material values for analyses, etc. It should be noted here that the stresses and strains from continuous operation with hot water are constantly underestimated by neophytes in the field. On the supplier's side as well these are naturally downplayed. However the planner must not become so cautious and conservative that he ignores new developments which would lower costs and represent advancement.

### 6.1.2 Supply Temperature

Because district heating service is developed for the most part within existing urban areas and since the servicing of recently built areas accounts for only a smaller portion of output, the temperature specifications of already existing indoor heating installations have to be complied with. These are mostly designed for the supply/return temperature range of 90/70°C for old and 70/40°C for new systems. Because existing secondary systems are usually oversized they can almost always also be operated at 80/60°C or even lower. Hence the minimum requirement from the consumer side for supply temperature in the district heating system is 80° to 90°C or 60° to 70° C in new systems.

The question of the supply temperature to select is not much easier to answer from the generating side. High supply temperature increases the transmission capacity of the network and reduces the requirement for capital investment. On the other hand, a higher supply temperature raises the cost of generating heat in combined power-and-heat operation. It also increases construction costs for pipeline systems. A figure cannot be quoted here since it has to be determined from specific analyses of economic viability. Following however are some broad points of information regarding supply temperatures used in various district heating networks in Europe.

As a rule district heat distribution networks are operated with varying supply temperatures. Specific to the country the maximum supply temperature is between 90°C (typical for instance to Denmark) and 140°C (typical for instance to Germany). This is discussed further in Section 6.1.3.

In addition to lower thermal generating costs (power-and-heat utilities, industrial waste heat), constant operation with lower supply temperature also offers important benefits from an engineering standpoint: the service life of polymer materials in general and plastic-sheathed pipe in particular increases sharply. Plastics may be used as a pipeline material,

heat compensation can be designed smaller or indeed dispensed with, etc. The advantages of operating with varying temperatures on the other hand are primarily better utilization of the transmission capacity of the network and lower volumes of water circulation.

Comparing the two approaches, there is a noticeable trend even in central Europe toward lower supply temperatures.

As to distribution, the situation regarding the transport of heat over large distances of more than 20 km say, presents a different picture. Here pipe systems of greater bore for high pressures are required. Their optimization may result in higher supply temperature. The transmission lines and the distribution network systems are then linked by appropriate converter utilities where pressure and temperature are regulated (cf. also Section 7).

### 6.1.3 Regulation of Output

In district heating networks output may be regulated by adjusting supply temperature or by altering the volumetric flow of hot water. There are two extremities as far as operating is concerned:

1. Temperature-only regulation  
The mass flow remains constant; output is increased only by raising the supply temperature.
2. Volume-only regulation  
Supply temperature is kept constant while output is regulated solely by means of mass flow.

In practice a combination of the two techniques is used allowing for a broad spectrum of options between the two extremes. To compare trends in this regard in various countries it must first be observed that the regulatory approach in Denmark comes closer to the volume-only extremity whereas for the most part Germany has implemented a temperature-control regulatory approach. German network systems are frequently operated with variable supply temperatures up to 130°C and occasionally as much as 140°C, with supply temperature not lowered below 70°C in summer because of the need for hot water supply.

supply temperature is raised with decreasing outside temperature, the maximum mass flow is reduced.

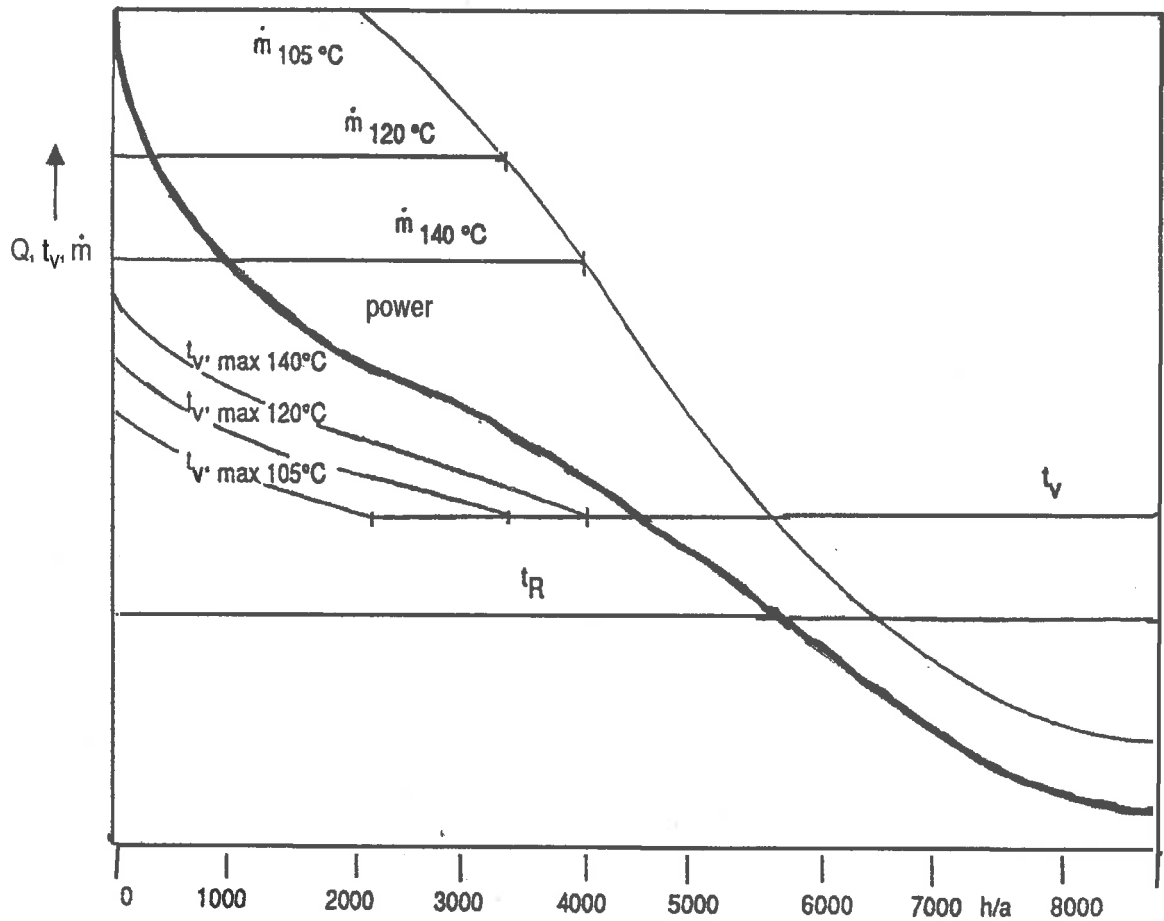

Fig. 6.1.3-1 Explanatory illustration of temperature and volume regulation in district heating networks [27]

As far as the actual regulation process is concerned there is a major difference between the two principles in terms of inertia. Using variation of mass, the requirement for heat output at constant supply temperature is regulated by altering the rate of mass flow in the circulating system. Using this technique even demand spikes can be dealt with at once via mass flow rate. Temperature regulation on the other hand is unsuited to accommodating sudden swings in demand. Travel time for the heat medium to reach the most-distant



customer may amount to as much as several hours in extensive networks, especially at low output.

The main advantages of temperature regulation lie in the fact that not only is heat loss lower but the energy required for water circulation is smaller as well.

The regulatory process has an influence on operating costs, primarily in terms of:

- pump power requirement,
- heat loss and
- utilization of the various generating facilities.

#### 6.1.4 Pressure Control

Pressure control establishes pressure level and allows pressure to be maintained (what is known as static pressure) following shut-down of the circulating pumps to prevent hot water evaporation. Static pressure must be high enough so that it remains above the saturated vapour pressure of the hot water. This also applies to the operating pressure which develops when the circulating pumps are on. Static pressure and operating pressure are equal only at the start-point of pressure control. The pressures are different at all other points on the distribution network.

The various mechanisms for pressure control are discussed in Section 7.2.2.

## 6.2 Economic Viability

Heat from large distribution systems is only to be sold at prices which are competitive with other heating systems (mostly gas or oil). This represents the so called investment price. For consumers the comparison of total heat costs is difficult, because cost structures of district heating and gas or oil generated heat are quite different. Total costs of a gas or oil heating system include besides energy costs the costs of servicing the capital investment.

Additional to these costs for servicing, maintenance and costs for the used room are to be considered. Therefore it is the task of the supplier to make the interrelations transparent to the consumer.

From the view of the supplier, heat from large distribution systems must be sold at prices which cover the costs incurred by the utilities plus an acceptable profit.

The maximum distance that heat can be transported is primarily a function of obtainable price, the costs of thermal generating and the network system costs.

From an economic standpoint a large heating utility can only be extended to the extent that the costs of heat generation and/or transmission of heat, heat distribution and delivery of heat remain below the investment price of the heat. This connection is shown in Fig. 6.2-1. The left column of the illustration shows that the sum of the costs from generation, distribution and miscellaneous (billing, insurance, administration, taxes, etc) must be below the investment price of heat. The boundary between generation and distribution is shown as variable: when heat generation is expensive there is only small scope for heat distribution.

The right-hand column of the figure further divides costs due to heat distribution into two parts: investment costs (fixed costs) and operating costs (variable costs). The height of the column is almost exclusively determined by the servicing costs on the investment.

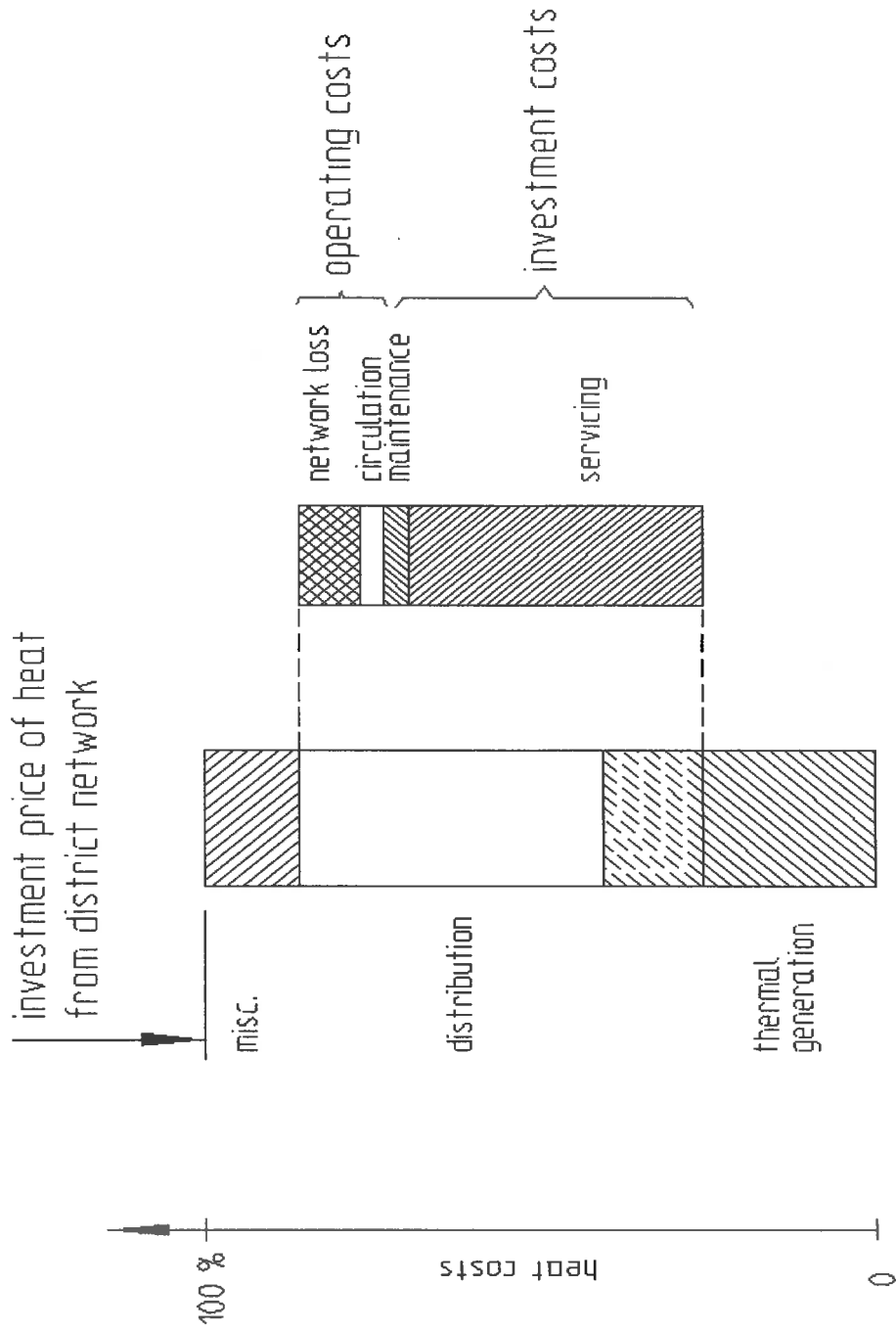

Fig. 6.2-1 Cost structure for district heating, qualitative

Of course the investment price of heat is not a fixed quantity but evolves with the behaviour of the marketplace. Accordingly the options and limitations for district heating services are constantly changing. These must be constantly monitored and forecasted for utilities planning.

Setting up a district heating system is capital intensive. In absolute terms, investment in heat-and-power utility is dominant for operating a combined power-and-heat system. These are used to provide simultaneous generation of power and heat for district heating systems. It is generally accepted that expensive systems are absolutely necessary for the generation of power. This then relativizes the costs of generating district heat since power is being generated as well as heat in the same system.

The relative cost components mentioned in Fig.6.2-1 are determined from specialized analyses of economic viability. These analyses usually follow a format as shown in Table 6.2-1. First, the necessary investment costs are determined and from these the annual capital costs. To these are added the annual operating costs. The sum of the annual costs is expressed relative to the amount of heat sold, yielding the costs per unit of heat. An important part is played by the credit entry for the power also produced from combined operation. It can dramatically lower heat costs under the right conditions.

In the following sections, reference will occasionally be made to this analysis format or the cost components from Fig. 6.2-1.

Lastly it should be stated, before the details of cost factors are discussed, that in the present book every effort is made to avoid citing absolute figures for costs. Although this may initially disappoint some readers, it is dictated by the requirement that the statements made here continue to be valid beyond national borders. Those in the industry are aware that costs and prices cannot simply be converted on the basis of exchange rates, not even among countries of the European Economic Community. For example, in the various countries considered here:

- fuel prices for coal and natural gas may differ by a factor of as much as 4,
- construction costs for district heating pipelines may differ by a factor of 3,
- in exceptional circumstances, differences in power prices may amount to as much as 400%, etc.

Consequently in a comparative look from one country to another it is not meaningful to quote absolute cost figures.

Because of this the present text tends to use cost relationships which are objectively valid.

No.	Type of cost	costs	annual costs	heat costs
<b>1.</b>	<b>Investments-Generation</b> (H & P utilities + heating plants)	\$		
1.1	capital costs - generation		\$/yr	
1.2	fuel costs		\$/yr	
1.3	operating costs		\$/yr	
1.4	less power credit		less \$/yr	
1.5	heat generation costs (1.1 to 1.4)			\$/MWh
<b>2.</b>	<b>Investments - Distribution</b>	\$		
2.1	capital costs of distribution		\$/yr	
2.2	operating costs - distribution		\$/yr	
2.3	heat distribution costs (2.1 + 2.2)			\$/MWh
<b>3.</b>	<b>Miscellaneous Costs</b>  heat billing charges, administration, insurance etc.		\$/yr	\$/MWh
<b>4.</b>	<b>Total Costs</b>			<u>\$/MWh</u>

Table 6.2-1 Format for determining the costs of long-distance thermal energy

### 6.2.1 The Cost Impact of Generation

The majority of the heat for district heating systems is generated in base-load heat-and-power utilities and the peak load portion in a heating utility. A heat-and-power utility produces high capital costs and low fuel costs. The situation is reversed for heating utilities. Generally speaking, the heat from a heat-and-power utility is more expensive when put out with higher supply temperature than with lower since in that situation the power loss in the heat-and-power utility is greater. Only in the open gas turbine process does this relationship not exist.

The supply temperature for a district heating network can be influenced by switching peak-load generation. The two may be switched in series or parallel so that heat is added to the base-load heat in the peak-load boiler.

A significant item in optimizing district heating systems is whether or not the costs of thermal generation are dependent on supply temperature or not. One should also determine if peak-load generation can be installed close to the main area of consumption. For the heat transmission installations this means that they can be operated under much more favourable economic conditions.

### 6.2.2 Energy Prices, Rates

In the energy marketplace, energy prices do not always find their own level since in a number of countries they are affected by energy policy. They influence the economic viability of long-distance thermal energy in a variety of ways. They have a direct effect through fuel costs but may also have an indirect impact via the competition situation in the energy market. Following is a discussion of three very different aspects relating to energy prices.

Fuel prices have a direct effect on the costs of thermal generation. The main alternative energies include coal, oil, gas, electricity and other.

At world market prices, coal is usually the least expensive form of energy. Because firing plants for coal also call for high outlay in terms of plant systems and operation, coal is favoured for base-load generation. Oil and natural gas generally have the same price level which is markedly above that of coal.

They are preferred in small heat-and-power facilities and peak-load installations. Under certain circumstances, power too plays a part in generation, e.g. night power from nuclear generating utilities or hydroelectric power in summer. If the price of power is sufficiently low, electricity may be used to generate heat, e.g. to drive heat pump installations or in electrically heated storage heating utilities. Garbage or waste is not looked on here as a fuel, since garbage incineration facilities are primarily built for waste disposal, with the resulting heat a by-product.

The second item affecting the economic viability of long-distance thermal energy is its competitive position vis-a-vis the consumer. The upper price limit of this thermal energy is roughly at the heating costs of the next cheapest energy form, e.g. fuel oil extra light. Should this limit be exceeded, customers will opt for fuel oil heating in a free market situation. This upper limit, i.e. the previously described investment price for long-distance thermal energy, defines the latitude available to the supplier of long-distance heating for development of his system. The sum total of the costs for generation and distribution must still be below this limit.

On the other hand, opportunities for developing district heating networks improve when the competitor energy is expensive. Then the investment price for long-distance energy is high, so that for a given producer situation there is greater manoeuvring room to develop district heating into a large-scale distribution system.

These mutual relationships are evident in the Scandinavian countries (except Finland, where the oil taxes are at the same level as in Germany). In Denmark, for example, petroleum prices are high with the result that heat is transported over great distances in conjunction with favourable generating capacities in large coal-fired heat-and-power utilities.

The third aspect of energy prices has to do with the price of long-distance thermal energy itself, specifically with price structure.

The main components of the price of long-distance thermal energy are the fixed costs from generation and distribution, the variable costs for fuel and operation and the costs for metering. On this basis, the cost of long-distance thermal energy is composed of the following components: basic price, running charge and meter charge.



It has proven to be good practice if price setting is oriented to the actual cost structure of the utility. Using this approach, the basic price in a long-distance thermal energy system with its established high capital commitment can easily amount to more than 50% of the selling price for the heat. Moving away from the real cost structure, e.g. by accounting for portions of fixed costs in terms of the running charge, a long-term phenomenon such as energy conservation - which after all mainly has an impact through the running charge - creates a widening supply gap for the utility.

### 6.2.3 Investment

The vast majority of investment in a district heating network is investment in pipeline systems. In addition there are outlays for the boiler house facility including the water circulation system and possibly for booster and suppliers service installations. The main objectives in the building of a pipeline system are low construction costs and a sufficiently long operating life of at least thirty years.

In district heating networks, small-bore lines make up a high proportion, whereas large-bore lines which come in sizes up to DN 1400, are proportionately few. Fig. 6.2.3-1 gives an idea of bore distribution in district heating networks. Cost reductions for small-bore lines are therefore especially effective.

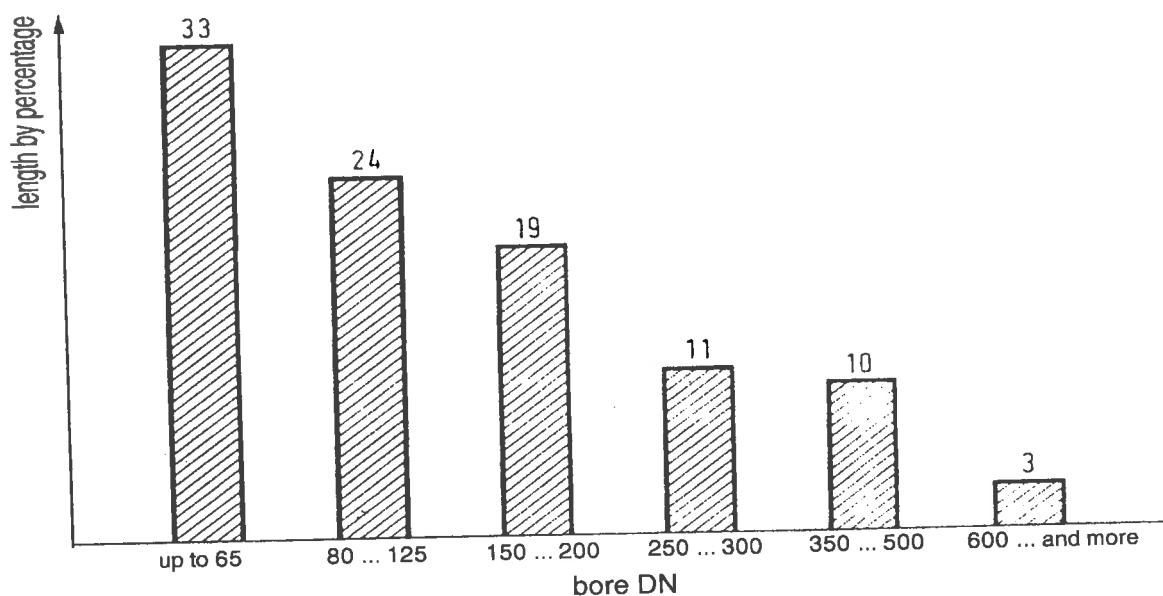

Fig. 6.2.3-1 Bore distribution in district heating networks

Because of the high costs of pipeline laying it is preferable if district heating lines can be laid in areas of high heat density. In these areas construction is bound to be more expensive due to various impediments. Costs are increased by road traffic, lack of working space, obstacles above and below the surface, etc.

A second important cost factor is the method of laying the pipe. Although today plastic-sheathed pipe is used almost exclusively for lines laid below ground, there are still other methods of laying lines. The relative cost aspect is shown qualitatively in Fig. 6.2.3-2. The figure gives a comparative look at methods of laying lines.

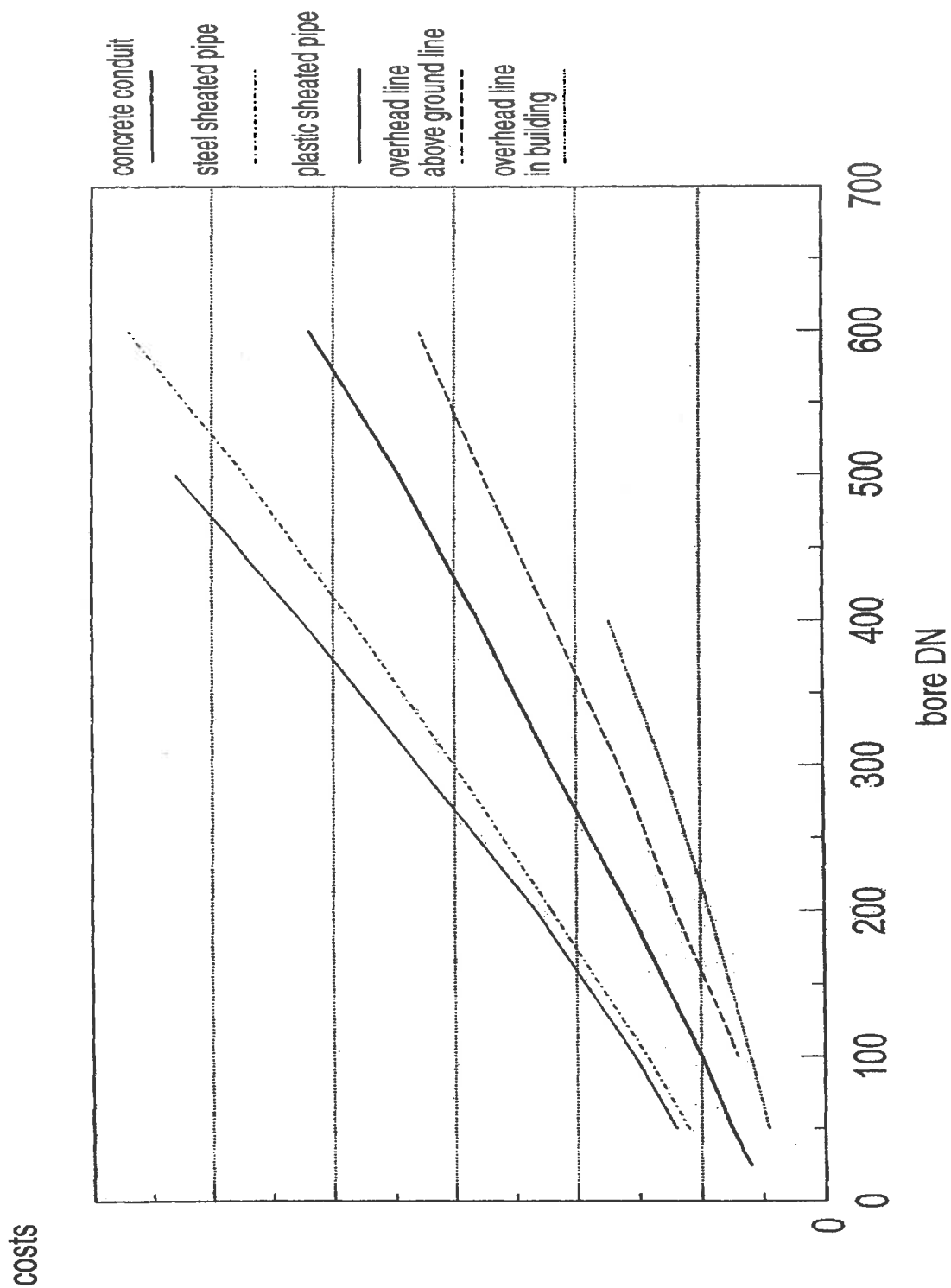

Fig. 6.2.3-2 Construction costs for district heating lines - standard values for various laying methods

Since reducing construction costs is the first priority of all those whose business is in the industry, there is an ongoing exchange of views on this subject in order to improve the technology, employ new materials, build more cost-effectively etc.

Looked at internationally, the costs of pipeline construction are very low in Scandinavia where in recent years they have been successful in systematically lowering the temperature level to below 100°C. The resulting reduced stresses have allowed simplifications in pipeline construction. In Denmark, with the low supply temperatures primarily in use there, there has been a trend toward use of small-bore medium pipe of plastic at very reasonable cost.

The low construction costs of network systems in Scandinavia are attained by laying their systems underground. The costs of materials do not differ greatly. Fig. 6.2.3-3 gives an idea of the various cost components in below-grade construction.

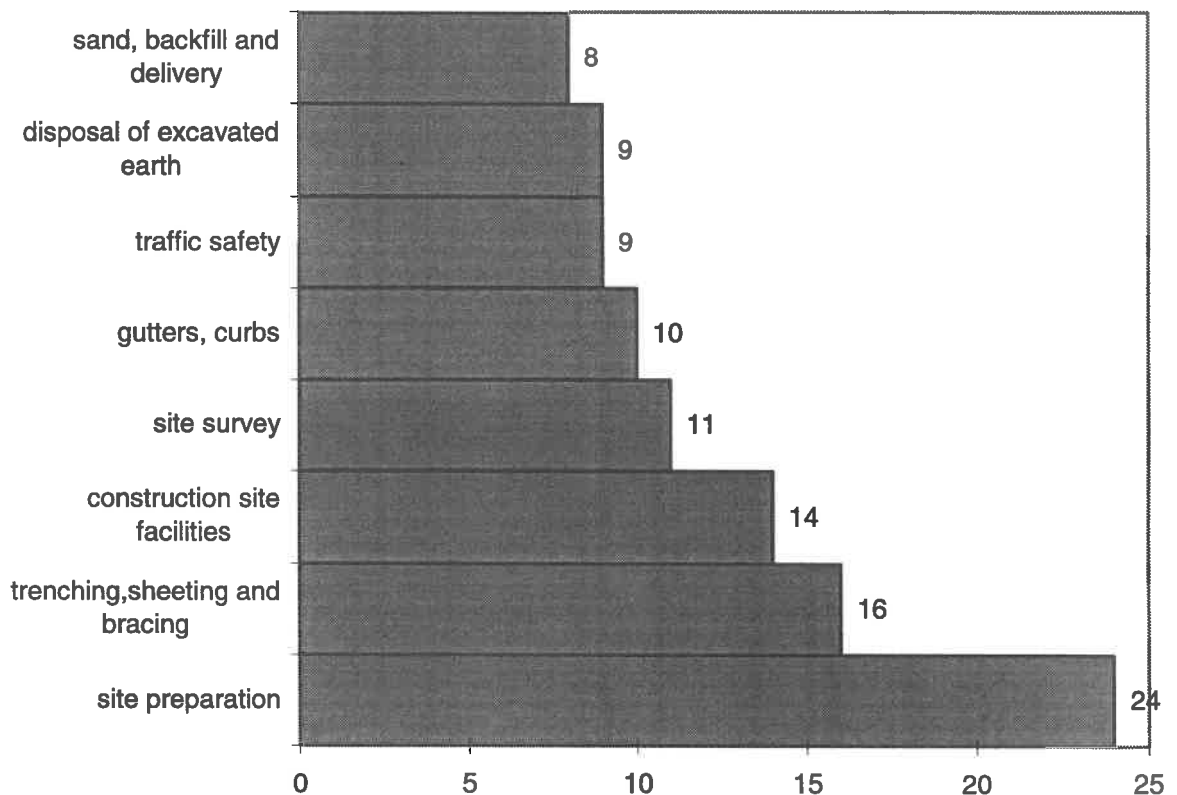

Fig. 6.2.3-3 The cost components of below-grade construction for small-scale construction projects [38] (c. 100 m line length)

The wide spread in the attainable construction costs always tends to start new debates on options for lowering costs. Fig. 6.2.3-4 shows actual costs in a number of cities for a variety of construction projects. From experience maximum values are 3 to 4 times higher than minimum values. Extremely high construction costs mostly result from special conditions.

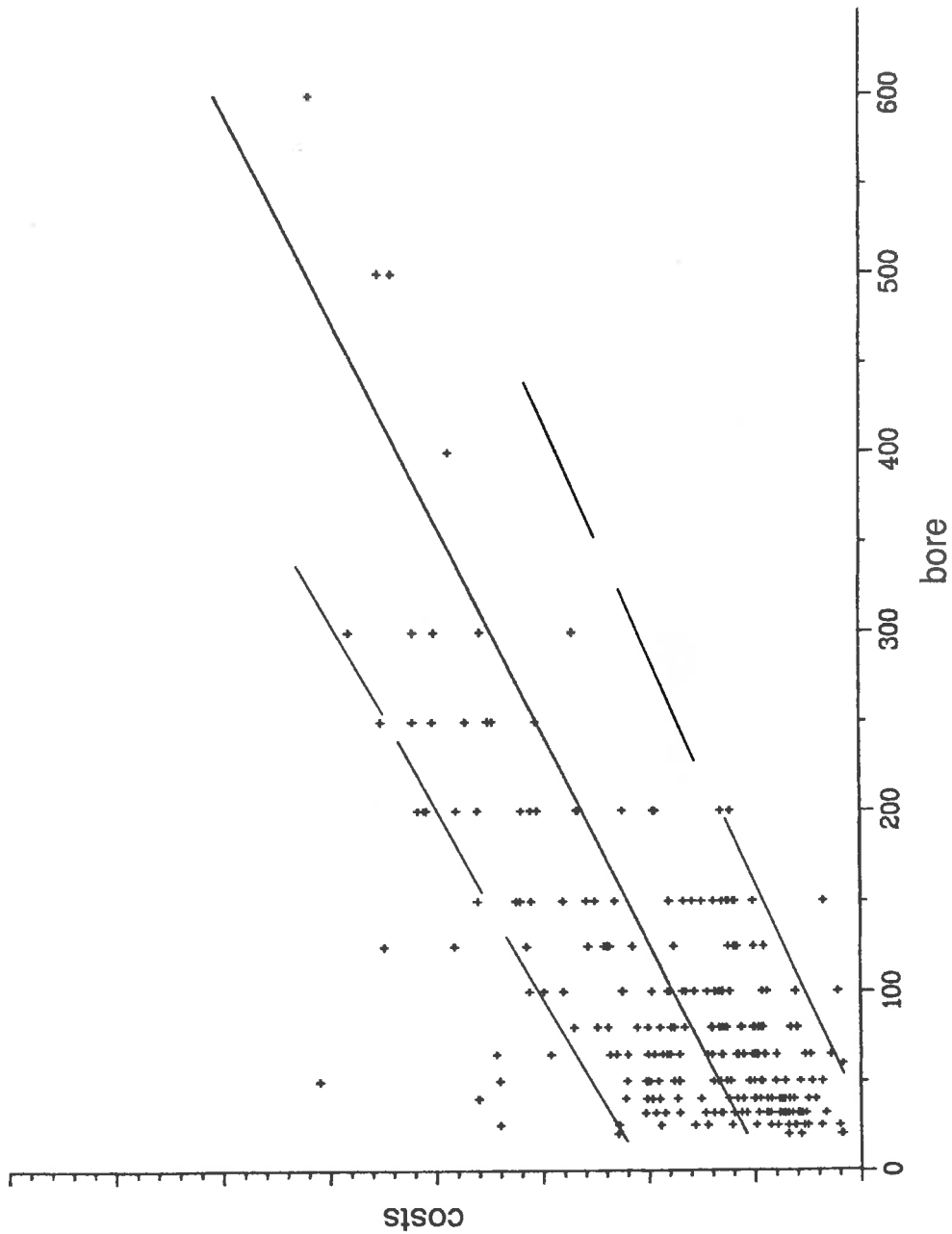

Fig. 6.2.3-4 Costs of laying plastic-sheathed pipe

Maintenance costs also represent a component of investment costs since they serve to maintain the value of the system. Because there is a relationship between the quality of the construction of lines and the required outlay for maintenance, there are certain variations in approach on the part of utilities. Following are commonly used:

trenched lines	between	0.7 and 2.0 %
above-ground lines	between	1.0 and 2.6 %
plastic-sheathed pipe steel in steel pipe	between	1.0 and 2.5 %
asbestos-cement pipe & poured asphalt process	between	1.5 and 2.5 %
condensate pipe	between	2.0 and 3.0 %

Occasionally, special values are applied for transmission lines and domestic service lines. For transmission lines they are then somewhat lower at around 0.5 % and for customer service lines higher than the figures cited above.

#### 6.2.4 Cost Impact of the Operating Parameters

In day-to-day operation, the operating parameters of temperature and pressure conform with the demand for output of the network. The design of the installations and hence the investment are determined by the maximum values of supply temperature and pressure. However because a district heating system is operated most of the time at partial output, the annual operating costs are created by the figures from actual operation.

Following is a discussion of the cost impact of the two operating parameters. The discussion involves the principal interrelationships and applies equally to heat distribution networks and for transmission lines over great distances. However because the operating parameters affect the costs of heat distribution or of long-distance transmission in different ways, different operating data are often chosen for the two areas. Frequently, large-scale transmission systems are operated using higher temperature and higher pressure.

### The Impact of Temperature

To discuss temperature it is necessary to distinguish among the effects of:

- supply temperature,
- return temperature and
- the temperature differential between outgo and return.

Modern district heating networks (mostly using variable operation) are operated at maximum supply temperatures between roughly 80° and 130°C. Because heat generation can usually be provided more effectively the lower the supply temperature, e.g. in combined heat-and-power operation, generation has a downward tendency.

One serious factor in building networks is the existence of an upper limit for supply temperature of about 130°C resulting from the construction costs of pipeline systems. Plastic-sheathed pipe, the most cost-effective type, may only be used up to 130°C.

As far as pipelines are concerned, reduction of supply temperature means an increase in the cross-sectional area of the pipe. This increases the investment required. However, low supply temperature also has a positive effect in that it simplifies construction (less serious heat expansion) and increases operating life, e.g. through slower ageing of polymer materials.

Low supply temperatures have a positive effect on operating costs in that they result in lower heat loss. On the other hand lower temperature for the power requirement of circulation means greater volumes of water and is undesirable. Generally however between heat loss and circulation, the advantages of lower heat loss prevail.

Return temperature should always be kept as low as possible since it directly affects transmission capacity. Today return temperatures between 60° and 40°C are attained, albeit the lower limit only in specifically designed domestic installations (standard in Finland). Indirect heat transmission will necessarily increase return temperature due to the effect of the heat exchanger. Frequently it is also overlooked that in principle mixing of the return in the domestic installation raises return temperature.

The temperature difference between supply and return is the truly relevant factor in the carrying capacity of a network, not the temperatures in themselves.

### The Impact of Operating Pressure

Distribution networks are mostly built in the rated pressure range of PN 16. Networks in the PN 10 range show little in the way of cost advantages. Maximum operating pressures of 10 bar are not often exceeded. There are even large district heating networks having more than 100 MW capacity in which the maximum operating pressure is less than 6 bar. This assumes however a network in level terrain and having direct servicing with a low level of building development.

A limiting factor from the consumer side with direct servicing is the maximum rated operating pressure in the domestic installation. Older customer installations or systems are sometimes only rated for a maximum of 4 bar. It may happen that a customer's system may have to be serviced through a heat exchanger.

While rated pressures of more than 16 bar in distribution systems require little more in the way of pipeline material, they do call for expensive hardware such as pumps, armatures, compensators etc. Pressure ranges of PN 25 and more are therefore only built in difficult terrain and for transmission lines. The optimal design pressure can only be determined from comparative cost studies.

## **6.3 Network/Customer Interchange**

The customer uses the heat from the network system for indoor heating and usually for hot water heating as well. Supplying hot water assures a partial load in summer and improves the economic viability of the district heating network.

Over the years supplying hot water has increased in importance as heating energy consumption has declined as a result of energy conservation. This has increased the demand for heat to provide hot water as a proportion of total demand: occasionally reaching as much as 25% of consumption.



### 6.3.1 Indoor Heating

The demand for heat from a district heating service is dictated from the customer side by the domestic heating installations. These are usually conventional radiator heating systems. By contrast, the forced-air heating systems used by industry, department stores etc. usually make lower demands on a district heating system.

The principal difference between direct service and indirect customer servicing via heat exchanger has already been discussed in Section 3.2. Both techniques have their proponents. On the whole the two variants occur with about the same frequency. Formerly, direct servicing dominated for cost reasons. It allows the building of very inexpensive customer service hookups and permits over a broad part of the service area water circulation in the customer's installation through the pressure differential offered by the district heating network. Since the advent of affordable element-type heat exchangers there has been an increase in use of indirect servicing.

The customer is given access to the system via the customer service installation. It contains the necessary regulating systems as well as a metering unit for billing. Service installations are standardized to keep building costs down. There are numerous hookup arrangements depending on the required operating data.

To illustrate the variety of styles and also the possible systems involved in customer service installations, reference is made to two stylized depictions [14]. Fig. 6.3.1-1 shows important styles of customer service installations differing in their hookup arrangements and the components used. The variety shown in the figure is not exhaustive.

Further on this topic, Fig. 6.3.1-2 shows a number of different regulatory variants. The service installations shown have various functions relating to the particular temperature factor and the output limit. Generally speaking, output limitation is included since at times of excessive output consumption there is danger of inadequate supply in other parts of the network.

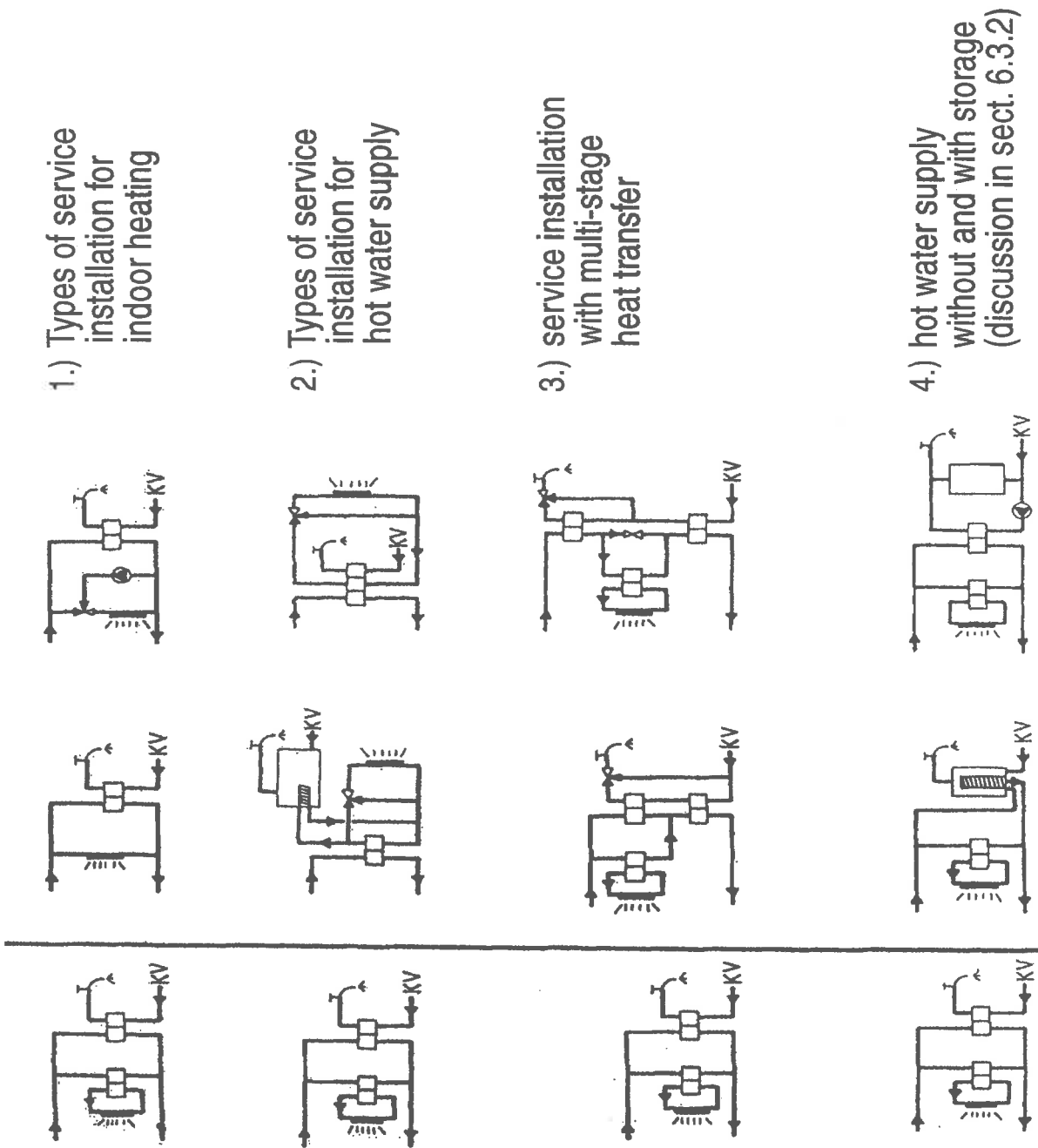

1.) Types of service installation for indoor heating

2.) Types of service installation for hot water supply

3.) service installation with multi-stage heat transfer

4.) hot water supply without and with storage (discussion in sect. 6.3.2)

Fig. 6.3.1-1 Common hookups for customer service installations; illustrations from Frederiksen/Werner [14]

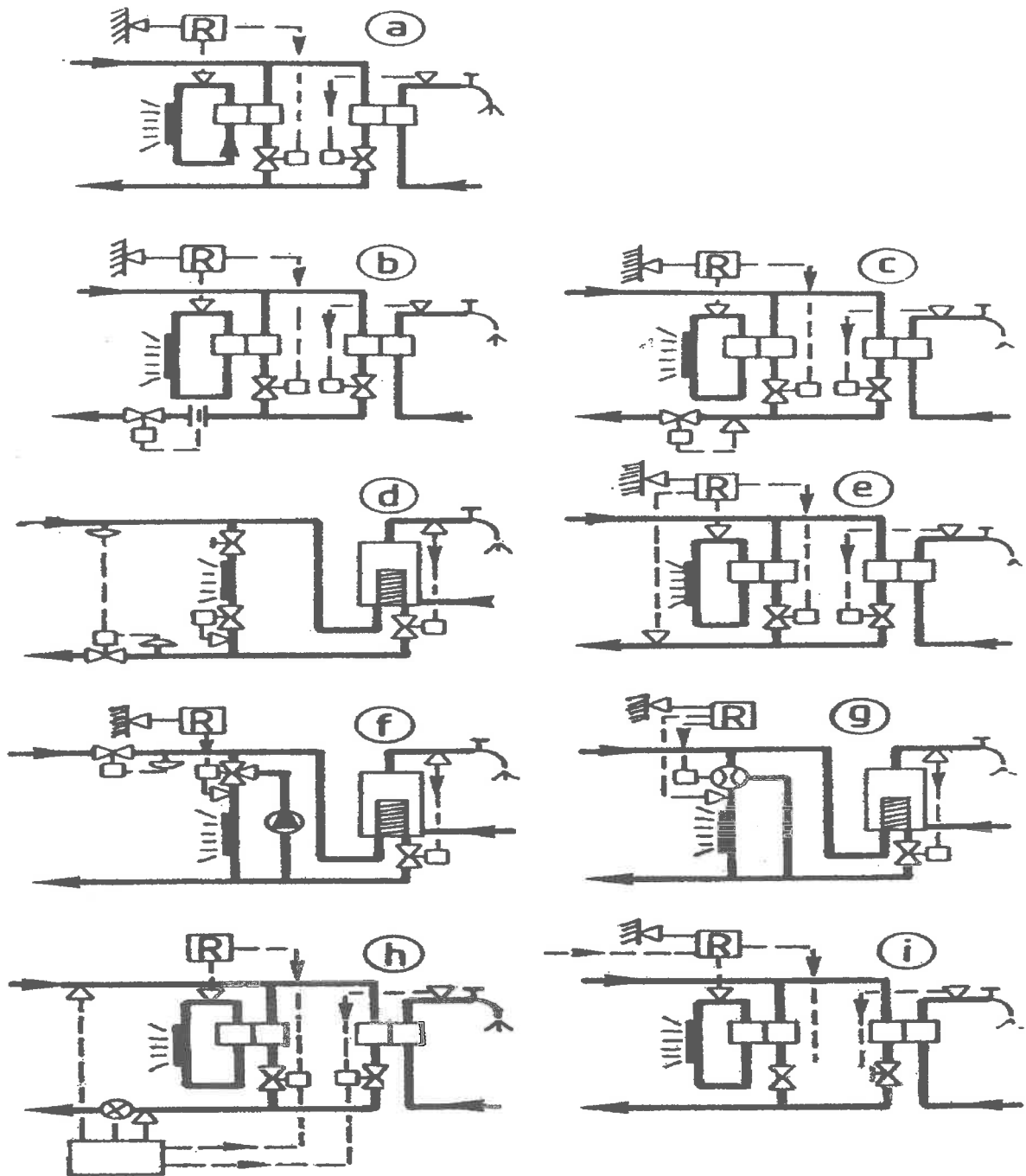

Fig. 6.3.1-2 Regulatory mechanisms in customer service installations from Frederiksen/Werner [14]

- a) indirect, no volume control
- b) with volume control
- c) with return temperature control
- d) with pressure differential control

- g) intermixing with jet pump
- h) electric volume control
- i) installation with remote metering

Many utilities and district heating organisations have guidelines for building consumer utilities, which consider the different prerequisites and provide a tried and tested concept for designers and fitters. As an example the guidelines of the Danish District Heating Association are reported in the following.

These guidelines give a number of examples of how a well-functioning district heating installation can be made. The types discussed are:

- direct single-flow installations,
- indirect installations with heat exchanger,
- direct installations in the form of a mixing loop with a 2-way automatic temperature regulation unit,
- direct installation in the form of a mixing loop with a 3-way automatic temperature regulation unit,
- indirect district heating installation with connection to a supplementary energy source.

The diagrams included are in the form of skeleton diagrams on pages 82-91. No dimensions are stated in the drawings, since dimensions normally depend on local conditions. Where some of the components have to be integrated, special considerations may need to be taken. This applies e.g. when integrating the meter in the installation.

The diagrams are very uniform and the numbering of components used in the installation has been standardized to ensure that one and the same component has the same number in all the diagrams where it is to be included. This means that the diagrams contain various number lines that have not been filled in, since the components covered by the given numbers are not used in the district heating installation concerned.

## **General requirements**

These guidelines apply to hot water installations with a flow temperature of up to 120°C. If a heating utility has requirements concerning connection arrangements, the requirements of the individual utility has priority over the general functional requirements given below. By the same token, deviations desired from the diagrams shown normally require separate approval from the utility in question; such deviating installations must be expected to have to comply with the requirements given below as a minimum.

It must be pointed out that some heating utilities do not allow all of the connection systems described herein; it is advisable to contact the utility before making the connection.

Because of the investment and operating economy involved as well as the operating conditions of the finished installations, attention is hereby drawn to the potential variations of the connection systems illustrated, depending on such factors as the utility's billing system.

A heating installation connected to a district heating system must have a connection arrangement which together with the other heating installation elements gives the best possible cooling of the district heating water. The connection system is the link between the service line of the district heating supply company and the user installation. Suggestions for various types of connection system can be seen from the following.

The heating installation must be made to ensure that the user has the greatest possible heating comfort while consuming the lowest possible amount of heat.

The user installation should be dimensioned to ensure that a cooling of min. 40°C of the district heating water is possible at full load.

If the district heating installation is to function satisfactorily, it is crucial for the individual components in the installation to fit together and to be dimensioned for the right pressure, temperature and load conditions. Since the temperature and load conditions in the distribution system may vary, depending on the location and the time of day, it is advisable to seek information about these factors before carrying out design work and connection.

When connecting special buildings, such as churches, castles or museums containing irreplaceable objects, indirect connection (through a heat exchanger) should be considered.

As a minimum, the connection system must include:

1. Thermometers for registering flow and return temperatures.
2. Valves for separate blocking of spatial heating installations and water heating installations.
3. Space for the meter assembly including valves to ensure that meter replacement can be carried out with a minimum of water loss.
4. A dirt strainer in front of the installation and in front of the meter.
5. Unions or flange joints to ensure that the connection system can be disconnected from the district heating system without cutting any pipes.
6. Branch pipes and valves for draining, ventilating and pressure-testing the installation.

Attention is also drawn to the requirements concerning heating and hot water installations contained in the building regulations.

### **Special requirements**

The heating utility may make special requirements concerning the design and operation of certain parts of the connection system, which is why inquiries concerning such requirements should always be addressed to the utility prior to carrying out the design work.

Examples:

- Some utilities insist that connection must be effected via a heat exchanger.

- Meter size and type often decide the dimension of the hot water preparation unit; also the pressure and temperature conditions at the utility may have a great impact on a particular part of the connection arrangement.
- Special requirements may exist concerning the placing of the meter, e.g. insistence on having „straight pipes“ before and after the meter, or concerning distances from other installations or building elements.
- The heating utility may insist on having a separate meter for specially heat-demanding individual components.
- The heating utility may insist on a minimum cooling of the district heating water, e.g. of 30°C.

### **Description of position/numbering of components in diagrams**

#### 1. Main valves of the district heating utility

The main valves are supplied by the utility. If a welded valve or a threaded valve is used, a union must be established just after the valve.

#### 2. Thermometer

Thermometers are placed in sensor pockets with good contact to the circulating water flow.

#### 3. Meter

The meter is dimensioned and supplied by the heating utility. Please note that the utility may have special requirements and guidelines concerning the meter and its placement.

#### 4. Stop valve

The stop valve must be dimensioned to match local pressure and temperature conditions.

5. Thermostatic valve

A thermostatic valve includes either an integrated sensor or a remote sensor. The valve regulates on the basis of return water temperature or service water temperature by means of a remote sensor. The valve is dimensioned to match load conditions and differential pressure.

6. Dirt strainer

Dirt strainers should feature an integrated solenoid.

7. Pressure differential regulator

The pressure differential regulator must be dimensioned to match load conditions and differential pressure. The pressure differential regulator can be placed on the flow pipe, but this involves a risk of air segregation in the radiators, depending on pressure conditions.

8. Pump

The circulating pump is selected by using the pressure loss in the internal heating installation under max. load.

9. Radiator valve

The radiator valve can be a thermostatic valve with room sensor, a thermostatic return valve or a manually operated valve. The choice of valve depends on the mode of operation, the function of the heating surface as well as the use and layout of the rooms to be heated.

Manually operated valves must be pre-settable and be able to provide a straight-line heat emission (exponential characteristics).

10. Non-return valve

The non-return valve in the mixing loop must protect the system against



shortcircuiting, and the non return valve at the meter is intended to protect against pollution of the meter during incorrect water filling.

11. Ventilation

Ventilation of radiators is effected by means of air escape screws.

12. Needle valve

Needle valves are installed on pipe branches located on the side of the main pipe to avoid transfer of air or dirt to the pressure differential regulator.

13. Connection of temperature sensors

Pipes for sensor pockets must be placed near the meter assembly with good contact to the circulating water; such pipes must be min.  $\varnothing$  25 mm, ending with a 1/2" or 3/4" sleeve and cap.

14.

15. Preparation of hot service water

The preparation of hot service water can be effected by means of an accumulating water heater or a flow-type water heater. The capacity of the tank must be dimensioned to match hot water consumption, district heating water cooling requirements, cold water pressure and differential pressure from the utility.

16. and 17. Motor valve

Correct dimensioning of the motor valve has a considerable effect on its operating capacity.

18. Control panel

The control panel for handling pulses to and from components, such as an outdoor sensor, flow pipe sensor or motor valve.

19. Flow pipe sensor

The flow pipe sensor is placed in a sensor pocket with good contact to the circulating water, at the greatest possible distance from the shunt line and after the circulating pump, if used.

20. Outdoor sensor and possibly spatial sensor

Normally supplied with the control panel.

23. Heat exchanger

The heat exchanger must be dimensioned to match the max. load, pressure conditions and cooling requirements concerning the district heating water. It must be noted that the heating utility may have special requirements concerning the connection of installations with a heat exchanger.

24. Expansion

Either pressure expansion or open expansion must be established.

25. Manometer

A pressure gauge must be established on the secondary side for checking the water coverage of the installation.

26. Safety valve

The safety valve must comply with applicable regulations.

27. Thermostatic valve

Thermostatic valve with a remote sensor for regulating the flow temperature on the secondary side of the heat exchanger. The valve must be dimensioned to match the load and the differential pressure.

**Direct district heating installations in the form of single-flow installations**  
(diagrams on pages 82 and 87)

**Definition**

A direct single-flow installation is defined as a connection system in which the district heating water from the distribution networks is circulated **directly** through the heating installation of the building and only flows through the radiators **a single time**.

**Use**

This connection system is the predominant one for single-family houses and small estates, and sometimes in somewhat larger installations.

### **Advantages**

The structure of the system is simple, which makes the system relatively cheap to install. One of the things that can be saved is a circulating pump. This system enables good cooling of the district heating water (i.e. good utilization). This is a financial advantage for the individual consumer where billing is by water volume metering (m<sup>3</sup> consumption), and it generally reduces losses in the street lines as well as the power for the pumps at the district heating utility block in question.

### **Disadvantages**

This system is not suitable for central control. Furthermore, residents can sometimes feel cold around the feet because radiators should preferably be cold or lukewarm at the bottom.

### **Function and operation**

**Hot service water** is heated in the hot water tank/water heater (15). For financial reasons, the service water temperature should be as low as possible; because of chalk precipitation, it should not exceed approx. 55°C. The service water temperature is regulated by adjusting the thermostatic valve (5).

**Heat regulation** is effected only via the radiator valves (9), since the pressure-differential regulator (7) is normally set once and for all and keeps a constant differential pressure via the heating installation in the building. Manually regulated radiator valves or thermostatically regulated valves can be used, either thermostats with a room sensor that keep a constant room temperature or return thermostats which ensure that the return temperature does not rise beyond the desired setting, i.e. thermostat setting.

The most economical operation is obtained by cooling the radiator water as much as possible. The bottom of the individual radiators should preferably be almost cold.

If night-time temperature-lowering equipment is installed, it is important to make allowance for the increased load during the upwards regulation period.

During the summer months, the heating installation may be shut off completely by closing valve (4) on the flow line to the heating installation.

### **Indirect district heating installation with heat exchanger**

(diagrams on pages 83 and 88)

#### **Definition**

An indirect district heating installation is defined as a connection system in which the district heating water (the primary side) is separated from the heating installation of the building (the secondary side) by means of a **heat exchanger**. This means that the heating installation of the building has its own separate circuit with a circulating pump and an expansion system.

#### **Use**

Principally, connection by means of a heat exchanger can be used for all sizes of installation.

#### **Advantages**

Indirect connection protects against the relatively high pressure from the heating utility and limits the amount of water damage in case of leaks on the internal installation. The system is suitable for central control.

### **Disadvantages**

The differential pressure of the district heat cannot be used as a driving pressure in the heating system, which means that an investment must be made in buying and operating a circulating pump/circulating pumps.

The district heating water cooling (utilization) is normally not quite as good in heat exchanger system as in single-flow system, which may affect the economy of running the installation.

### **Function and operation**

**Hot service water** is heated in the hot water tank/water heater (15). For financial reasons, the service water temperature should be as low as possible; because of chalk precipitation, it should not exceed approx. 55°C. The service water temperature is regulated by adjusting the thermostatic valve (5).

### **The heat exchanger (23)**

In relatively small installations, a heat exchanger with spiralled tubing or a plate heat exchanger is used. The heat exchanger has been designed in accordance with the counterflow principle, where the district heating water (the primary side) is taken through the heat exchanger going one way and the local radiator water from the heating installation of the building (the secondary side) is taken the opposite way. In larger installations plate heat exchangers are most frequently used, also based on the counter-flow principle.

**Heat regulation** is effected by means of central temperature control, which may be supplemented by regulation on the radiator valves. Manually regulated radiator valves may be used, but thermostatic radiator valves are more common.

The flow temperature to the radiator system is regulated on the thermostatic valve (27) according to the season and the desired room temperature, but must be set at a temperature

which at all times is lower than the flow temperature of the primary side, since otherwise the cooling conditions in the heat exchanger would not be reasonable.

If the return temperature from the radiator system is too high, the flow temperature must be increased, and at the same time the radiator valves (9) must be closed somewhat (does not apply to thermostatic valves).

To ensure quick, accurate regulation of the radiator water, the sensor for the thermostatic valve (27) should be installed as close to the heat exchanger as possible, preferably submerged in the heat exchanger on the secondary side flow to the radiators.

Correct dimensioning of the circulating pump (8) is of great importance when it comes to obtaining a good operating economy. A pump with variable output is to be preferred. It is important to note that, if over-sized, the pump will unduly increase the water circulation in the system, which normally results in less cooling of the district heating water.

The most economical operation can be obtained by having the greatest possible cooling of the radiator water. The bottom of the individual radiator should preferably be almost cold.

During the summer months it is possible to shut off the radiator system completely by turning off valve (4) on the flow line to the heat exchanger (the primary side) while at the same time stopping the circulating pump (8).

### **Direct district heating installation with mixing loop**

(diagrams on pages 84, 85, 89 and 90)

#### **Definition**

A direct district heating installation with a mixing loop is defined as a connection system in which the district heating water from the distribution network circulates **directly** in the heating installation of the building via a **mixing loop** in which the flow water from the distribution network is mixed with the return water from the radiators.

## Use

Mixing loop installations are used mainly in relatively large installations and sometimes also in smaller housing blocks. Rarely used in single-family houses. The system is particularly suitable where central control of the system is desired that includes a variable flow temperature to the heating installation.

## Advantages

In connection with central control, a mixing loop installation can be connected to an automatic temperature regulation system ('climate system') with outdoor sensor, flow pipe sensor and, possibly, a spatial sensor, as well as with a 24-hour regulation program, including night-time temperature-lowering, and a week program, if required. Furthermore, it is possible to split up the facade and have a lower temperature on the sunny side than on the shadowy side via several mixing loops and such a feature as especially low temperature for floor heat, if installed.

## Disadvantages

In a mixing loop installation, the differential pressure of the district heating cannot be used as a driving pressure in the heating system, which means that an investment must be made in buying and operating a circulating pump/circulating pumps. The district heating water cooling (utilization) is normally not quite so good in heat exchanger as in singleflow systems, which may affect the economy of running the installation.

## Function and operation

**Hot service water** is heated in the hot water tank/water heater (15). For financial reasons, the service water temperature should be as low as possible; because of chalk precipitation, it should not exceed approx. 55°C. The service water temperature is regulated by adjusting the thermostatic valve (5).



**Heat regulation** is effected by means of central temperature control, which may be supplemented by regulation on the radiator valves (9). Manually regulated radiator valves may be used, but thermostatic radiator valves are more common.

The temperature of the mixing loop is controlled by a thermostatic 2-way or 3-way valve (possibly a motor valve) (16) or (17), which depending on the rate of operating allows a smaller or greater amount of district heating water to be mixed with the return water from the radiators.

To ensure good functioning of the installation, it is important for the thermostatic valve/motor valve to be dimensioned to match the right load and the available differential pressure. If the thermostatic valve/motor valve is too big, it will tend to oscillate. To compensate for the variation in differential pressure, it is possible, as shown in the diagrams, to install a pressure differential regulator. This is significant especially where motor valves are used. Because of the substantial load variation experienced over a year, it is preferable in some cases to have a „summer valve“ and a „winter valve“.

Correct dimensioning of the circulating pump (8) is of great importance when it comes to obtaining a good operating economy. A pump with variable output is to be preferred. It is important to note that, if over-sized, the pump will unduly increase the water circulation in the system, which normally results in less cooling of the district heating water.

The most economical operation can be obtained by having the greatest possible cooling of the radiator water. The bottom of the individual radiator should preferably be almost cold.

If night-time temperature-lowering equipment is installed, it is important to make allowance for the increased load during the period of upwards regulation.

During the summer months it is possible to shut off the heating installation completely by closing stop valve (4) on the primary side flow line to the heating installation, while at the same time stopping the circulating pump (8).

**Indirect district heating installation with connection of supplementary energy source** (diagrams on pages 86 and 91).

This section deals with user installations that have supplementary energy sources for district heating, such as various pumping installations, solar heat or wood and chip firing features.

In this connection, connection is required to go through a heat exchanger as outlined in the skeleton diagrams on pages 86 and 91.

These diagrams only give **one possible suggestion** as to how to organize the secondary side; however, **many different solutions are possible**, depending on the nature of the supplementary energy source, the heat volume, the possible temperature conditions, etc.

The consumer must ensure that the installation is made in accordance with applicable authority requirements, such as publication no. 58 from the Danish Labour Inspection Service (Arbejdstilsynet): **Stipulations concerning un-fired hot-water installations** (central heating installations with heat exchangers), and publication no. 42: **Stipulations concerning fired hot-water installations**. It must be noted, for example, that not all supplementary energy sources are allowed connection with the expansion tank closed.

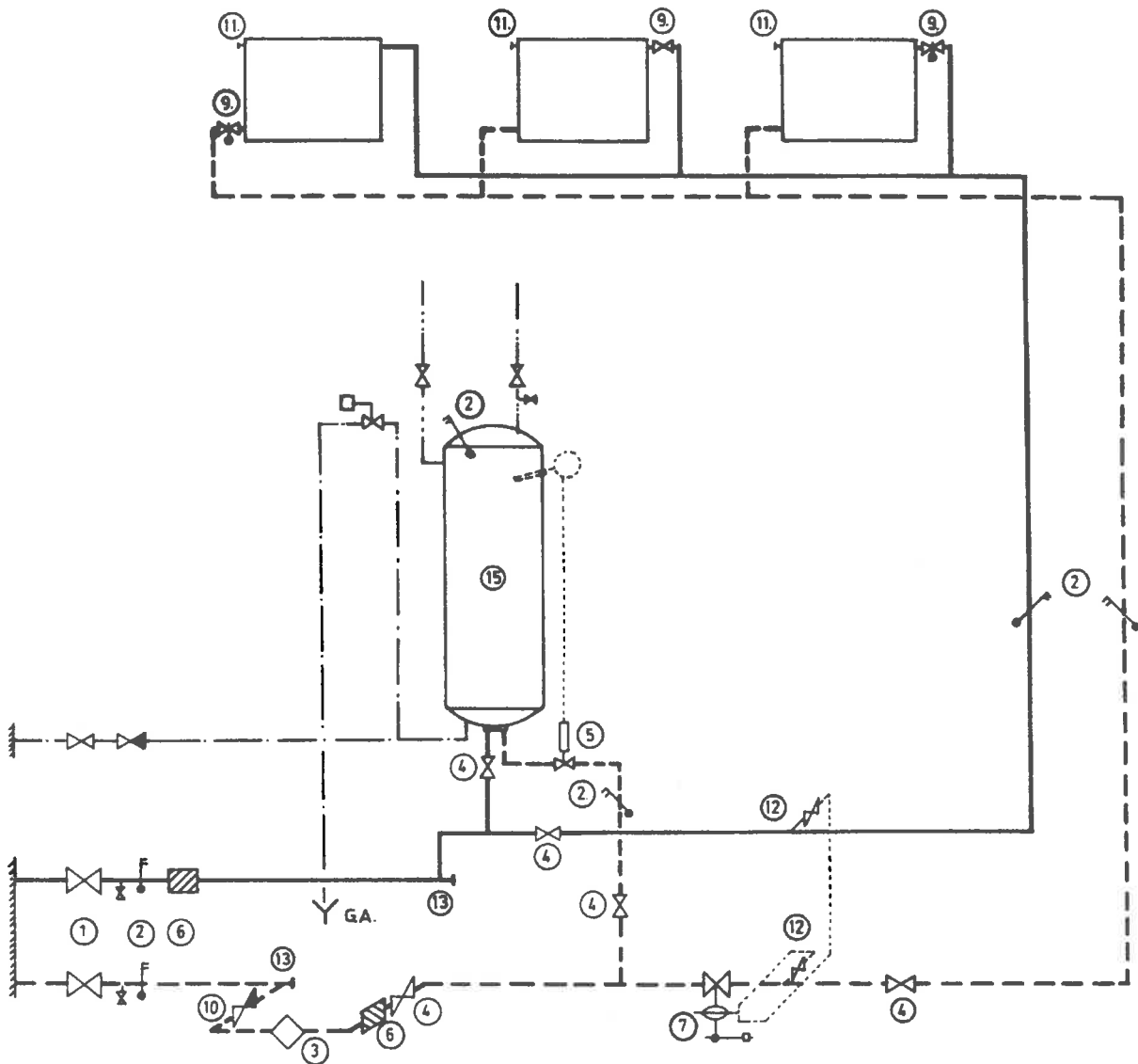

Numbers refer to numbers in text from page 70 ff

DIRECT  
DISTRICT HEATING INSTALLATION IN THE FORM OF A SINGLE-FLOW  
INSTALLATION

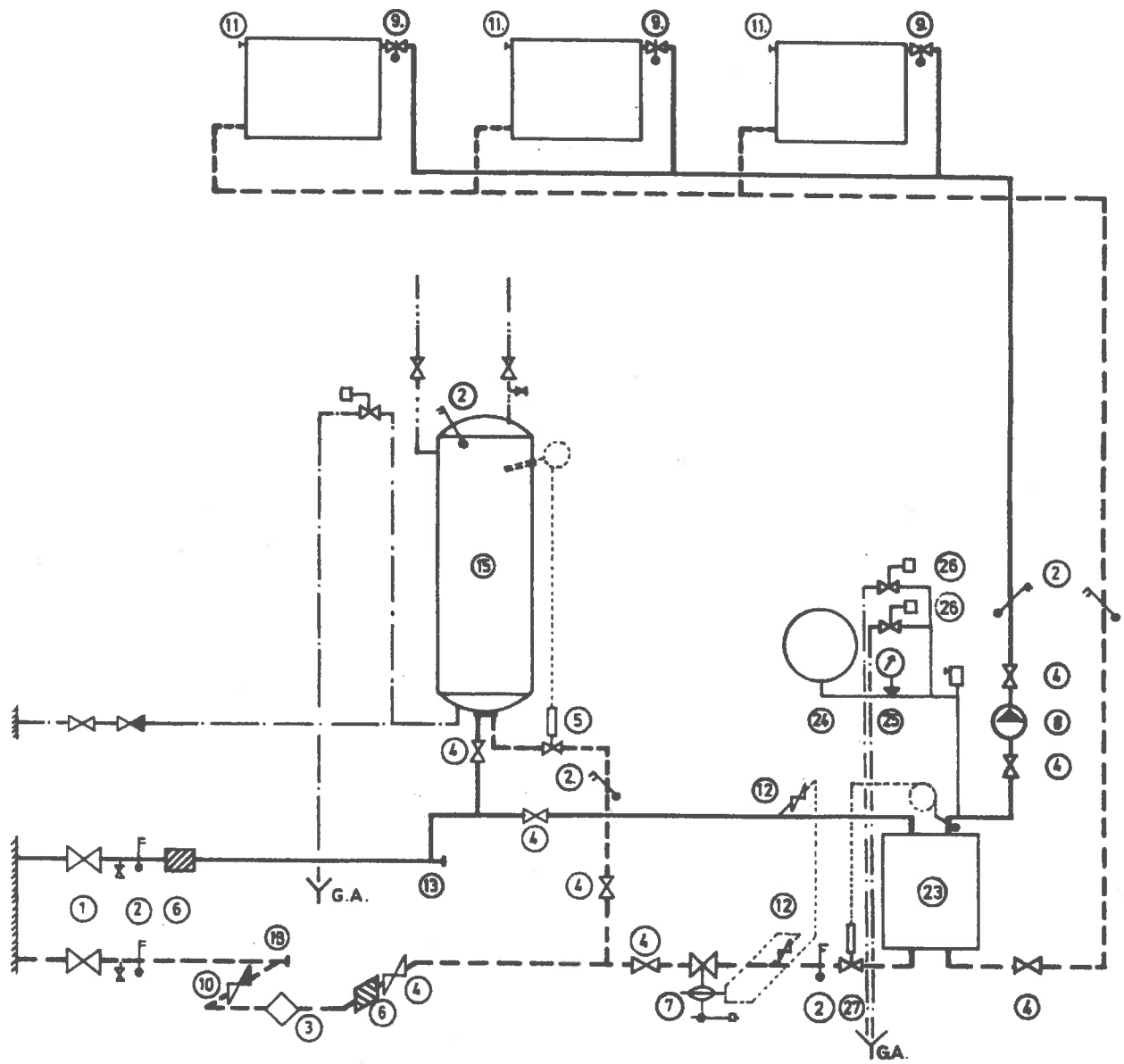

INDIRECT  
DISTRICT HEATING INSTALLATION WITH HEAT EXCHANGER

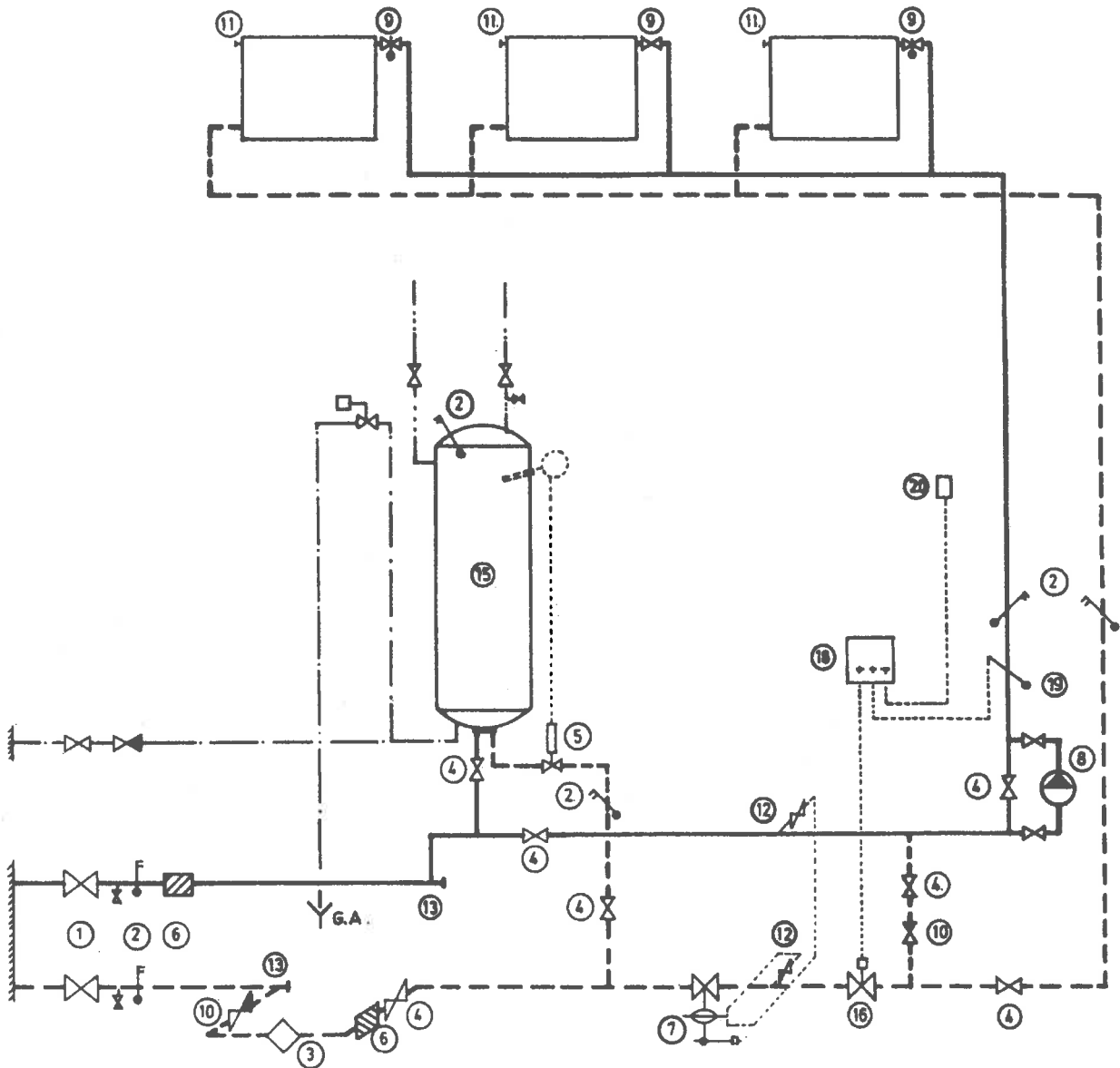

DIRECT  
DISTRICT HEATING INSTALLATION WITH MIXING LOOP  
2-WAY TEMPERATURE REGULATION SYSTEM

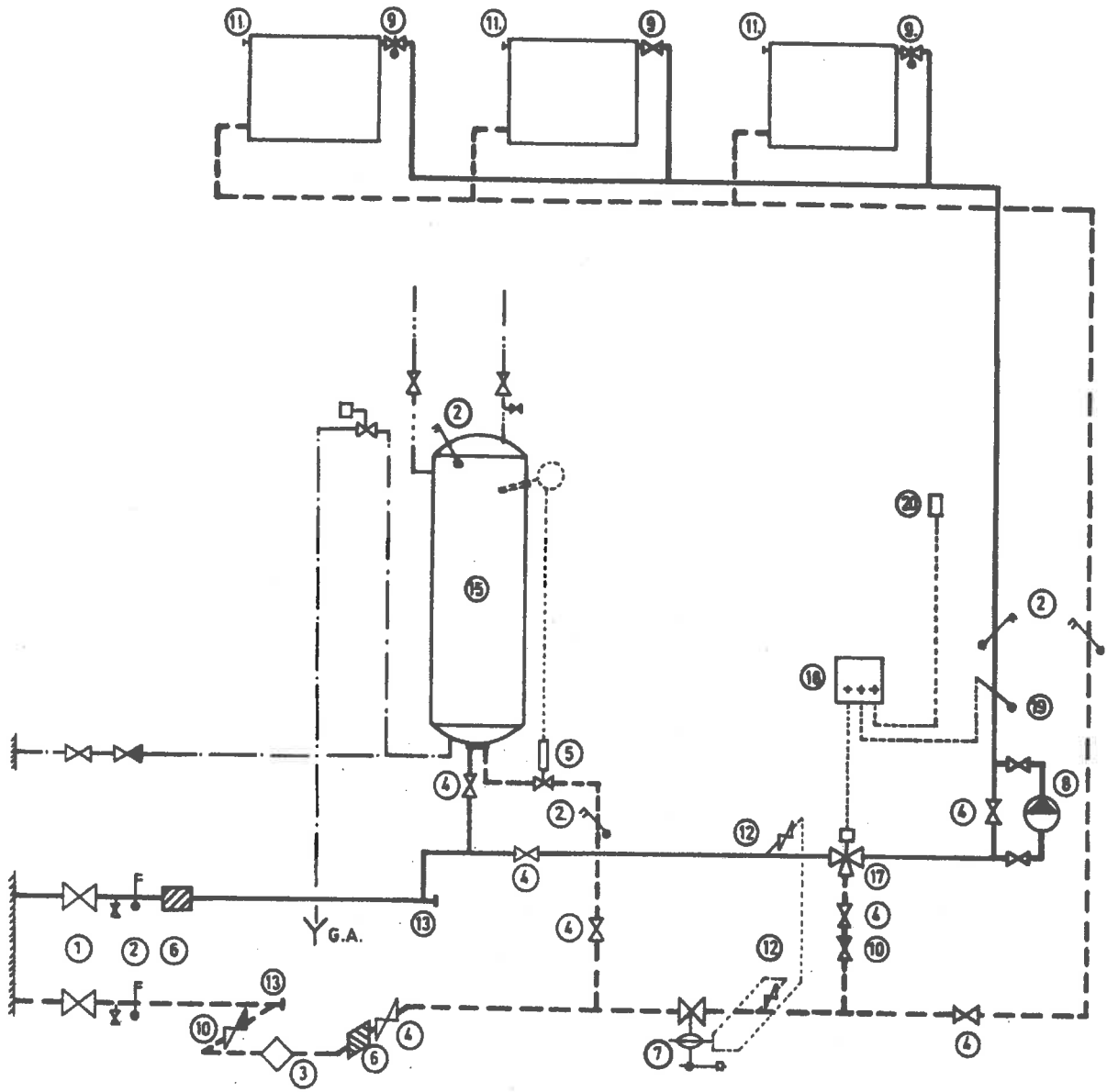

DIRECT  
DISTRICT HEATING INSTALLATION WITH MIXING LOOP  
3-WAY TEMPERATURE REGULATION SYSTEM

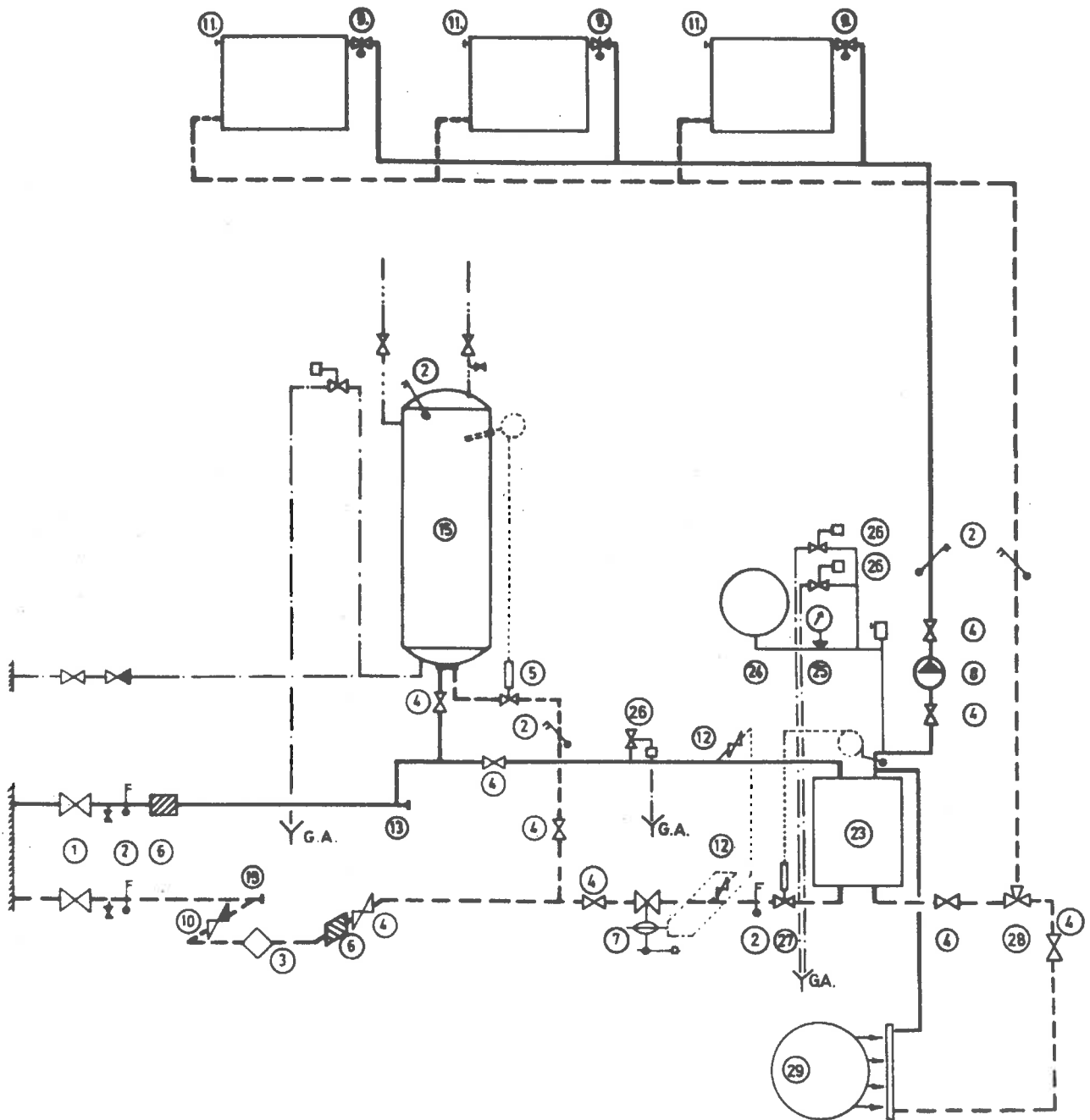

INDIREKT DISTRICT HEATING INSTALLATION WITH CONNECTION TO A SUPPLEMENTARY ENERGY SOURCE

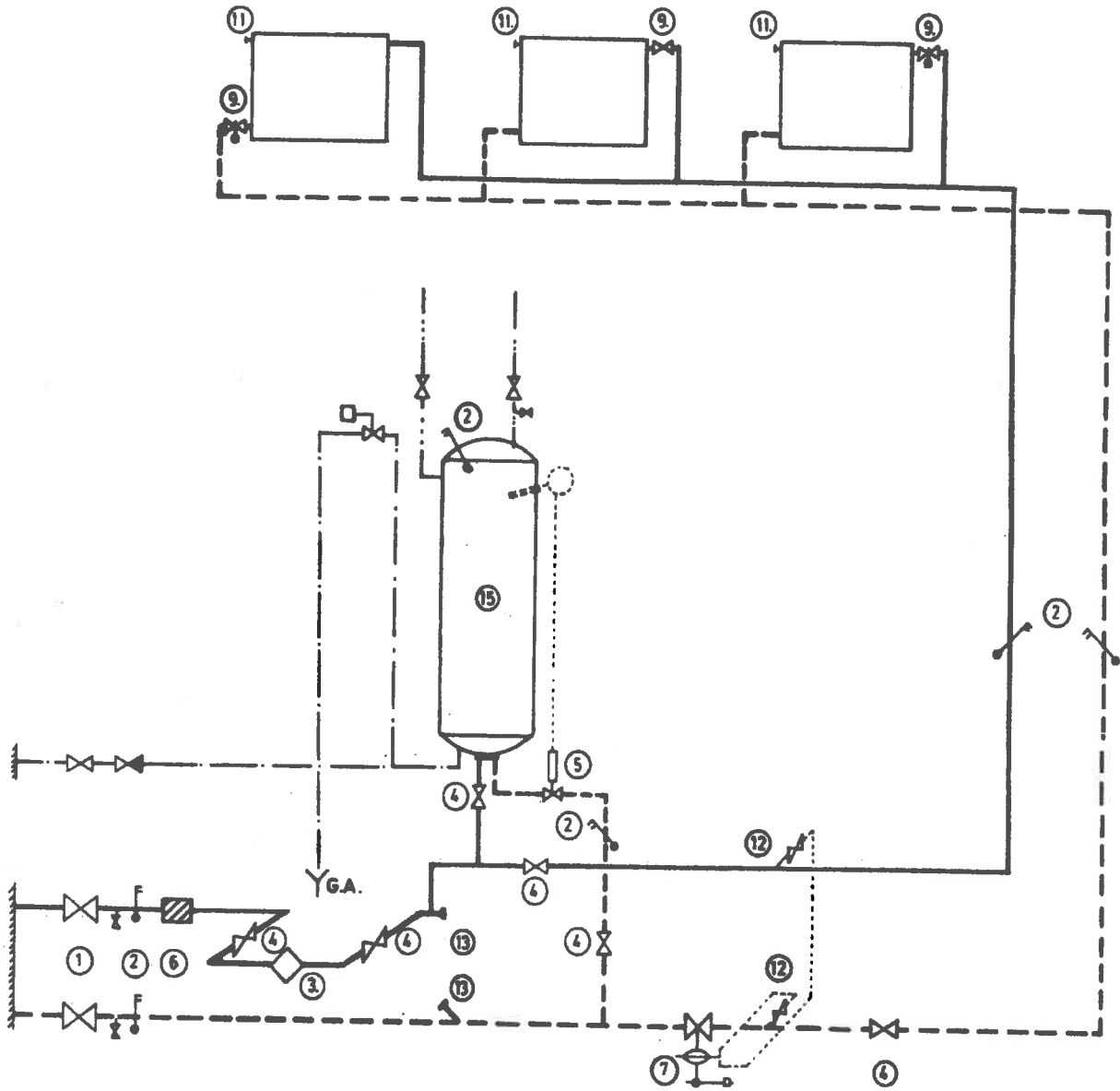

DIRECT  
DISTRICT HEATING INSTALLATION IN THE FORM OF A SINGLE-FLOW  
INSTALLATION



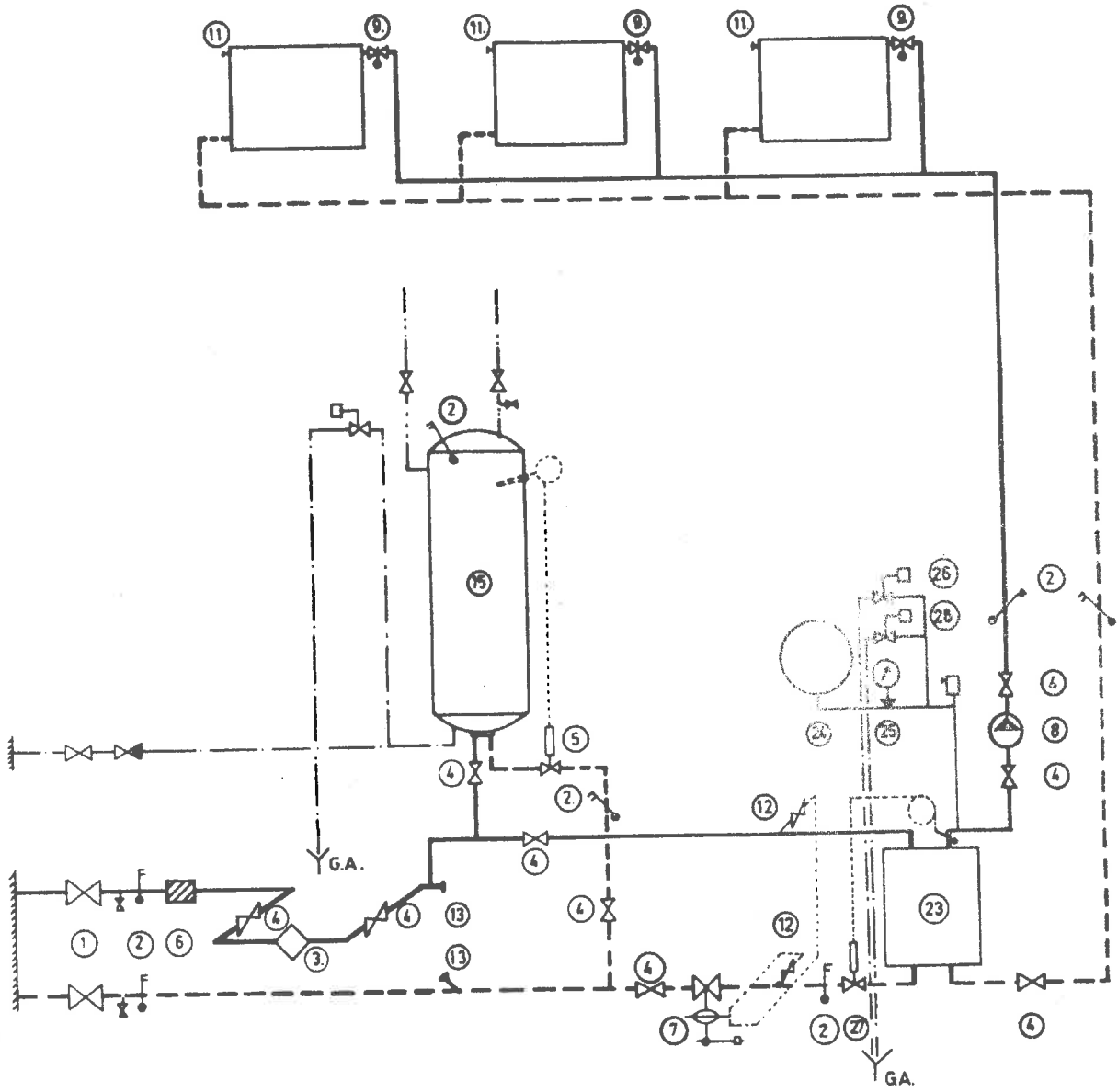

INDIRECT  
DISTRICT HEATING INSTALLATION WITH HEAT EXCHANGER

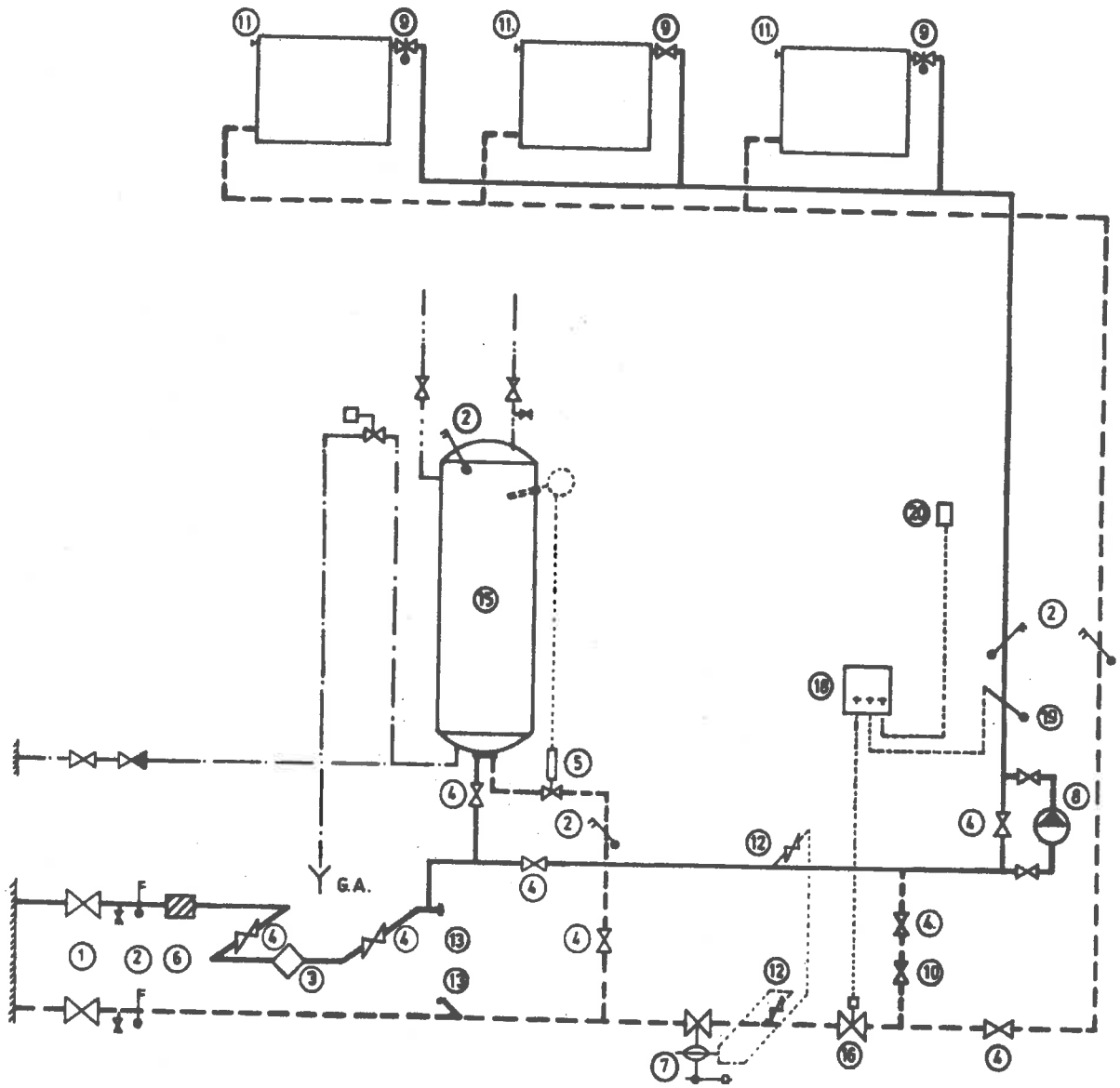

DIRECT  
 DISTRICT HEATING INSTALLATION WITH MIXING LOOP  
 2-WAY TEMPERATURE REGULATION SYSTEM

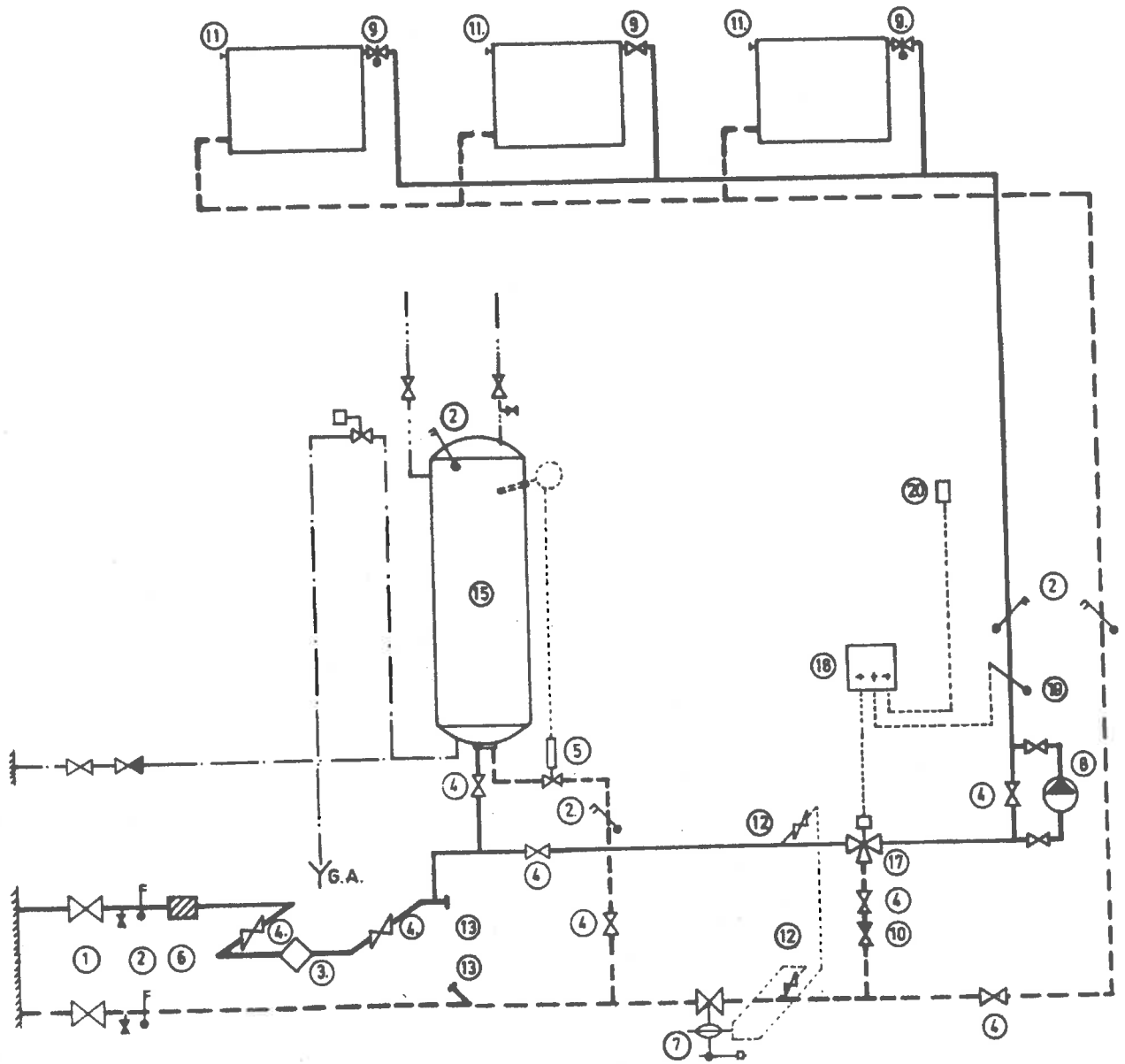

DIRECT  
 DISTRICT HEATING INSTALLATION WITH MIXING LOOP  
 3-WAY TEMPERATURE REGULATION SYSTEM

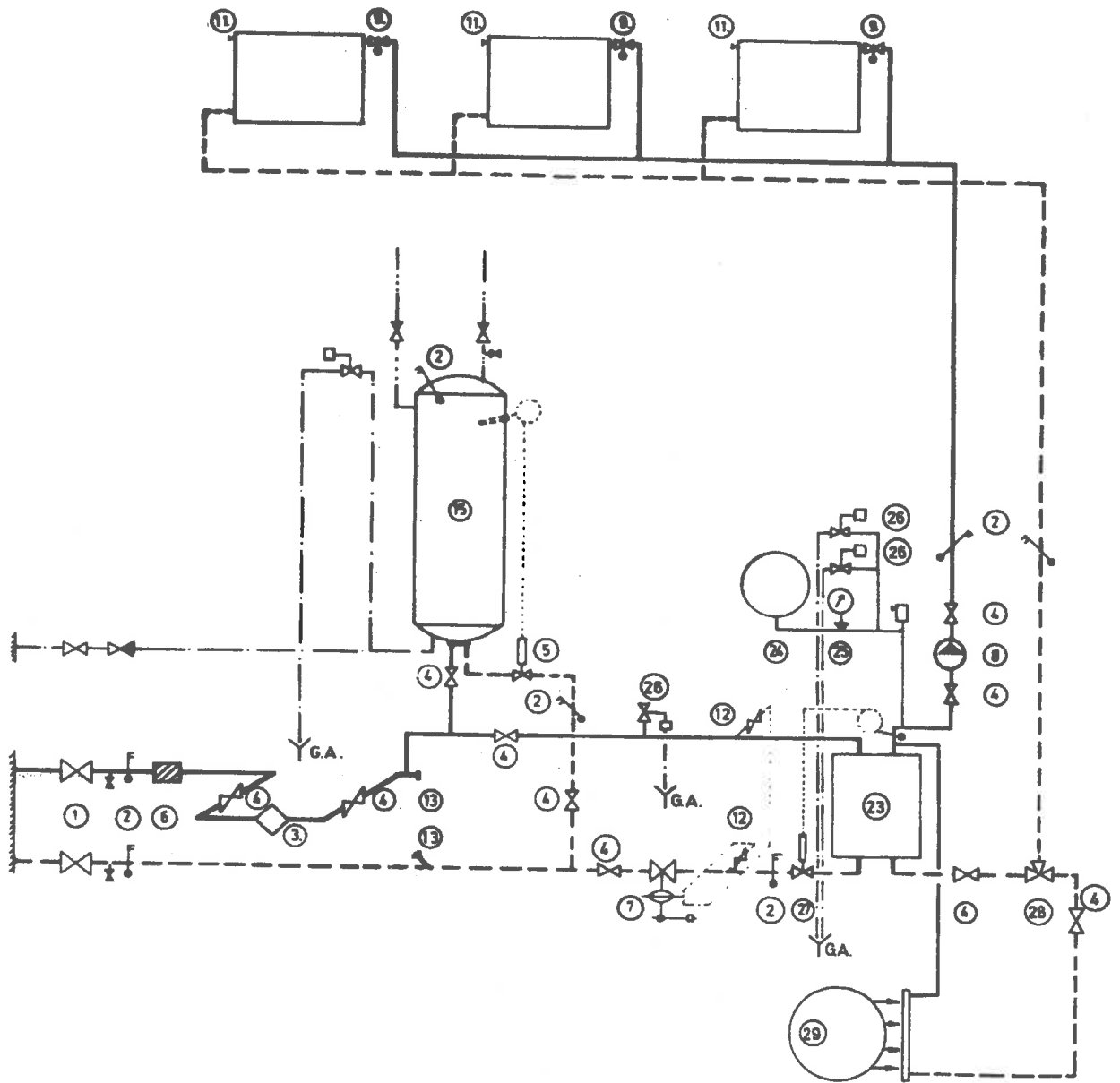

INDIRECT DISTRICT HEATING INSTALLATION WITH CONNECTION TO A SUPPLEMENTARY ENERGY SOURCE

The design of the customer service installation determines the return temperature. Utilities, which strive for low return temperatures for business reasons, must find a compromise with the consumer since for the consumer low return temperatures mean greater radiator surface area and consequently greater outlay. In this context the situation for service hookup to new structures or older buildings is not the same. In the case of new buildings, the added costs of greater heating surface area are usually tolerable for builders. However in providing service to older heating systems expansion of the effective heating area is usually not feasible. It is of course established that in older domestic heating installations the effective heating surfaces are quite oversized. Frequently these have also become too large owing to systems relating to energy conservation. All these reserves should be utilized as much as possible to lower return temperature. Experience has shown improvement in cooling down by 10 to 20 K to be possible.

Older installations in Europe are usually designed for temperatures of 90/70°C. Today, district heating utilities usually contract with their customers for a return temperature of 50°C.

Information from Finland is that 40°C is being specified for new installations.

If it is desired to lower return temperature in an existing heating network system to improve cost-effectiveness, this is usually done in numerous smaller steps of a few degrees. This involves feeling out the capacity limits of the customer's heating installation. Where capacity limit is not met, and this is actually only a few installations, remedial action is called for.

### 6.3.2 Hot Water Supply

Customer consumption of heat for hot water amounts to roughly 20% of annual consumption. On the other hand the demand for output from small consumers may even exceed the consumption for indoor heating. Provision of hot water has a low coincidence factor. Additional spikes in heat consumption for hot water are not desirable in district heating networks. In order that consumption for hot water heating not be superimposed on consumption for indoor heating, hot water heating systems may include a priority arrangement which allows interruption of the indoor heating system while hot water is being heated. The consumer is not aware of brief interruptions in heating of as much as half an hour or more.

Demand spikes can be reduced if the hot water system is combined with a heat reservoir. Heat storage increases the outlay required and the heat losses. Item 4 in Fig. 6.3.1-3 shows the principal hookups for hot water heating. Hot water heating using the flow principle creates the highest demand spikes; heating via heating coils in large storage tanks the lowest. The 3rd version illustrated shows the storage booster system which allows direct control of consumption used for hot water heating through use of a booster pump. In the storage booster system the required storage volume is lower than in the storage tank system by a factor of 2 to 3.

### 6.3.3 Heat Metering

Billing of the heat delivered to the customer by the utility is done on the basis of the set maximum energy consumption and the volume of heat metered. Only in exceptional cases is flat-rate billing or estimated usage etc. employed. The accuracy of metering must be to government standards. Metering systems must be serviced and inspected regularly.

Metering systems operate on the principle that the volume flow of hot water and the temperature difference between supply and return have to be measured separately. The two values are fed into the computing system which calculates the amount of energy. The flow meter is installed in the return line because it is exposed to lower temperature stresses there. Common small heat consumption meters use turbine meters to measure volume. For large metering systems, measurement of volume employs ultrasound or the induction principle. Specific information on heat metering should be discussed with equipment suppliers or if need be acquired from literature in the field.

Especially in areas with low-consumption customers, there is the danger that overly complicated metering will force the costs of measurement up to unacceptable levels.

## 6.4 Early Financial Problems in Developing a District Heating Service

In establishing a district heating service or expanding one, generating and network systems have to be set up before service can begin. Work has to be done beforehand which makes the starting phase unremunerative. Usually the expenditures of a utility in the starting phase cannot be offset by revenues. This relationship, which is established in an operating budget,

is represented graphically in Fig. 6.4-1. The diagram shows profit and loss over the initial years.

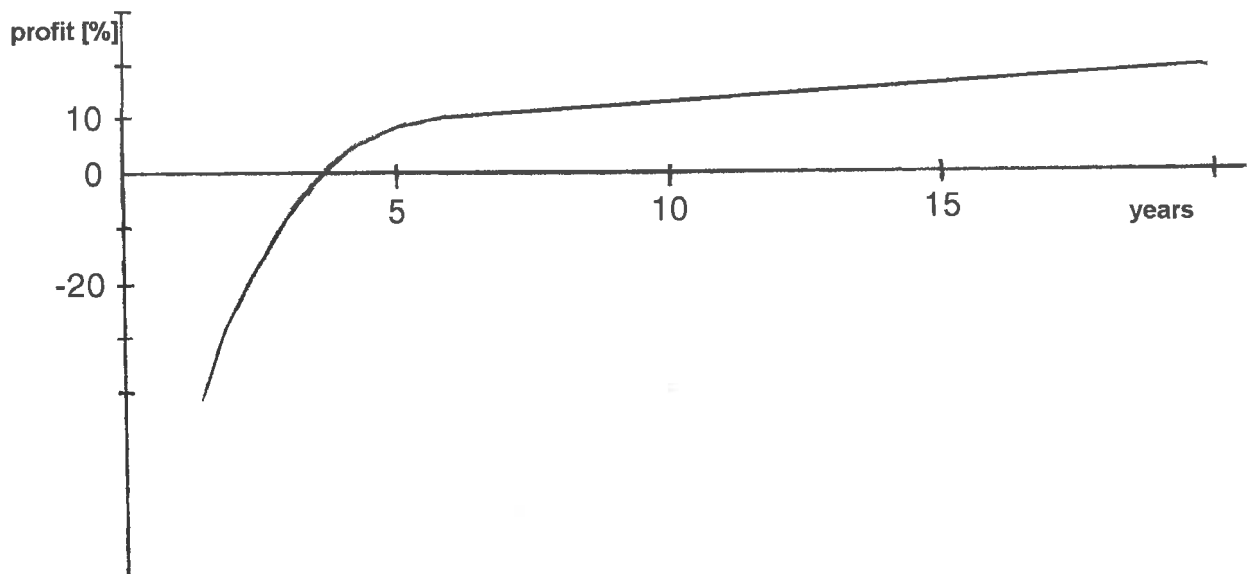

Fig. 6.4-1 Profit and loss in establishing a district heating service, graphic representation

The objective of the early strategy must therefore be to keep the annual start-up losses as low as possible and to cross the threshold of profitability at an early stage. Whatever the case, the objective in the interests of economic viability is to extend full servicing to the planned consumers as early as possible and/or to strive for a high level of service in the proposed service area.

The servicing of a given area with district heat is greatly dependent on its consumer structure. An area of high heat density is desirable: one in which consumption is confined to a small number of large consumers. An area with numerous, uniformly distributed small consumers is not desirable. If it is assumed at the outset that network investment will increase in linear fashion with the length of the system, the undesirable case can be shown by a chart showing the percentage of installed line versus the district heating demand. This is shown graphically in Fig. 6.4-2, curve 1.

In practice of course, the size of customers' consumption is not uniform, thus giving the supplier the option of first servicing the more profitable customers before bringing the smaller consumers on line as well - cf. curve 2. This can result in considerable economic advantage since it may be possible, even with a relatively small installation outlay, to achieve significant heat output. The prospective economic return from developing a district heating service has to be determined from specialized economic analyses.

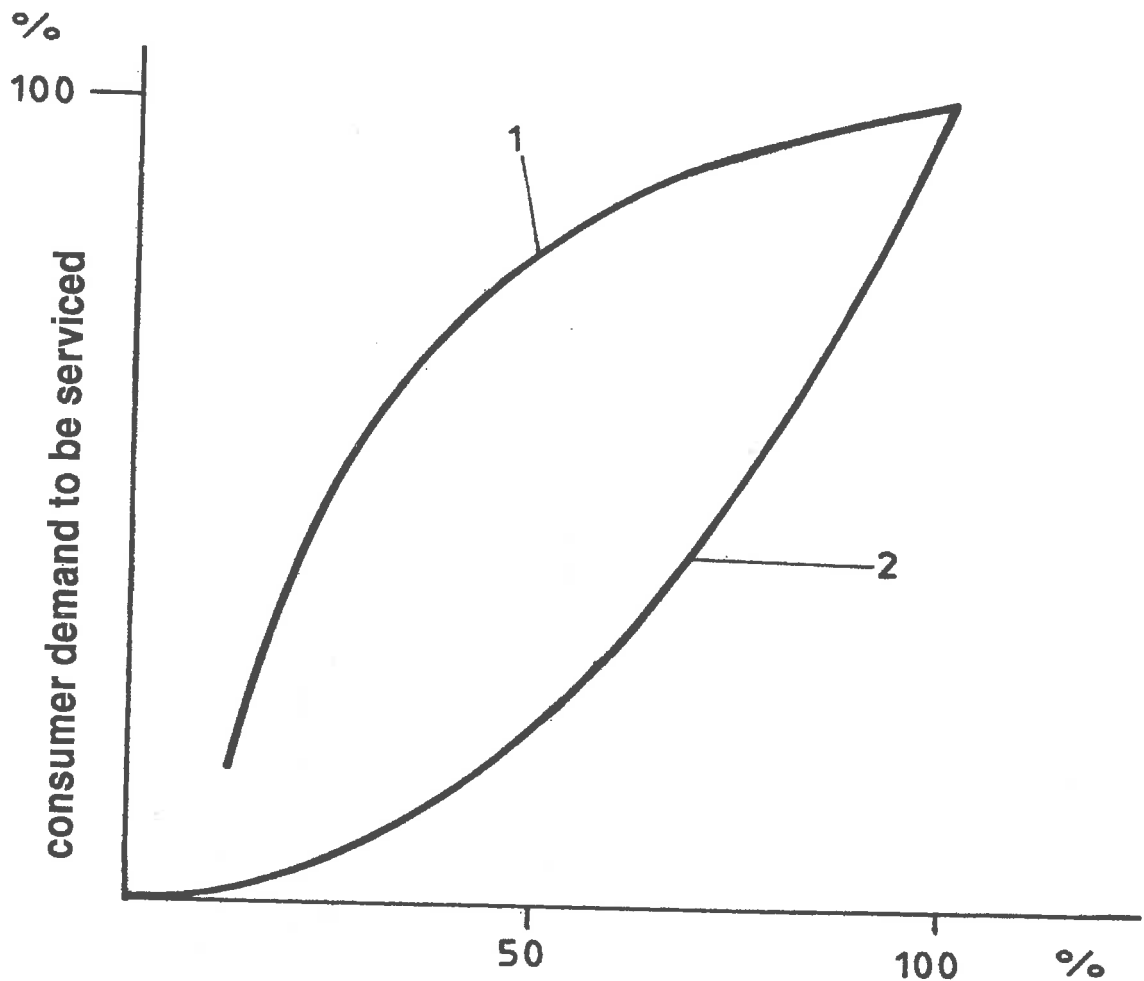

Fig. 6.4-2 Schematic representation of development strategy

As has already been shown, the starting phase is the most difficult period economically in the development of a district heating service. Subsequently the proportion of unutilized capacity becomes smaller and, of particular note, the benefit of decreasing costs can be utilized as the system increases in size.



Under conditions suitable for pipeline construction, cost savings can also be achieved on a small scale by servicing additional customers. This phenomenon can also be used on a large scale by consolidating large district heating networks into a combined operation supplied from a single major generating utility.

Decreases in costs are particularly large for small generating facilities. This is also evident from Fig. 6.4-3 which shows how heat costs in an urban area can be lowered by consolidating separated networks. The left-hand column shows the heat costs of a case involving an area supplied by a number of separated networks with capacities from 8 to 20 MW. If the same consumers are consolidated into four sectors so that units of about 50 MW in size result, the costs are those of the middle column. The right-hand column applies to a consolidated heat unit capable of about 200 MW peak output; it displays the lowest costs.

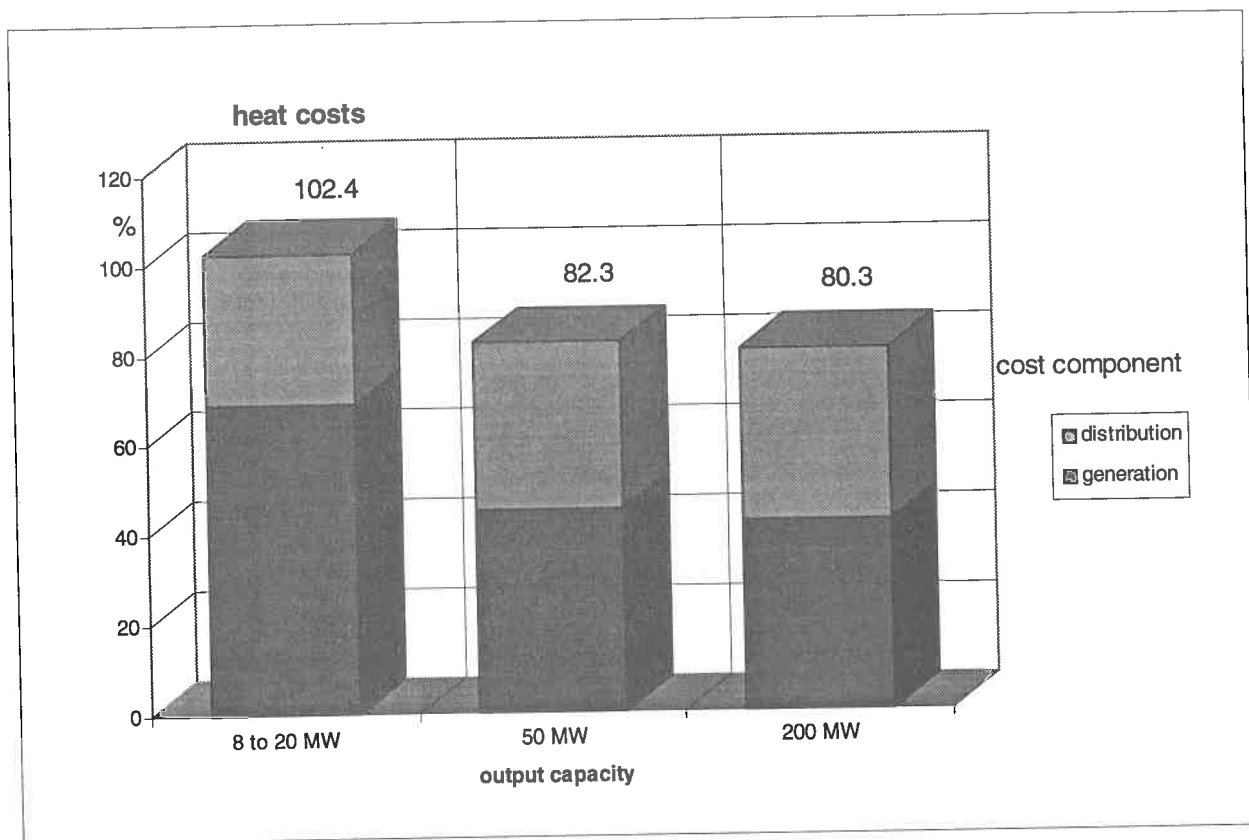

Fig. 6.4-3: Cost reduction as a result of size

Major consolidations of district heating systems have tended to take place wherever major generating utilities are located close to heavily built-up urban areas. In these areas transportation systems are economically attractive which move heat over distances of up to 20 km and more. In Denmark with its string of major coastal power utilities run on imported coal, distances of more than 50 km are spanned.

## 7. Planning of District Heating Systems

The construction of district heating systems can take at least ten years, with large systems often in construction or expansion over decades. During this time numerous construction measures must be undertaken, including both large projects for transmission mains, distribution lines and pumping utilities as well as small projects for the many individual service connections, line extensions to the next residential street, and so forth. Planning thus ranges from individual large high-cost undertakings to a multitude of small construction sites requiring ongoing management. And there are any number of intermediate stages between these two.

The steps in the planning of these systems are described below. The work of the planning engineer is outlined first in an introductory section, followed by advice on market-gearred collaboration with the firm performing the construction work.

The remaining sections deal with technical matters: first, the hydraulics of circulation and pressure maintenance, then specialized issues of long-distance heat transmission. Other questions dealt with include static and thermal considerations as well as ways of reducing operating costs.

### 7.1 General Remarks

The key planning objectives are:

1. a high degree of reliability in operation,
2. low construction costs, and
3. long service life for facilities.

Fulfillment of these objectives requires both in-depth technical expertise as well as cost-conscious and business-like handling of construction projects. For this reason both technical and market-related issues must be dealt with.

#### 7.1.1 System Planning Process

In commercial practice there are two types of planning for district heating:

- ◆ simplified planning and design
- ◆ detailed planning and design.

Simplified planning and design reduces to a minimum the client's planning costs by focusing exclusively on essential design criteria. The design approach is generalized, with simplified methods and tables. Little attention is paid to ways of reducing costs through

consideration of all route and system relevant aspects. With this approach the contractor assumes the risks of unforeseen cost rises during the implementation stage.

An alternative to the simplified approach is detailed planning carried out by experts and based on a detailed determination of all construction requirements, thereby making precise calculation of construction costs possible. The client bears the risk for uncalculated overruns during implementation.

Both methods are used. The difference lies in the shifting of planning costs to other entities and in the shifting of cost risks.

Experts generally agree that careful detailed planning results in the lowest construction costs. For this reason it is this approach that is outlined below.

Detailed planning for district heating must produce the following results:

1. Clear specifications for the construction work to be performed and a schedule of materials with detailed estimates in order to arrive at accurate pricing without contingency allowances and to avoid subsequent contract amendments.
2. Complete and detailed planning documents (route, elevation and other detailed diagrams) with all required measurement, load and other design data, as well as clear instructions for the construction process.

Such planning specifications enable the contractors to do their work in an efficient manner.

When the steps in the work of the planning engineer are examined, the necessity of close cooperation with suppliers, local officials, property owners and others is immediately obvious. Figure 7.1.1-1 identifies these steps and divides them into four phases, with indications of the interaction with other participants. The figure should be regarded as a basic outline that must, of course, be adjusted for regional construction regulations, local conditions, current safety rules, standards, etc.

Sections 7.2 to 7.5 focus more closely on certain special technical planning steps.

### Phase 1

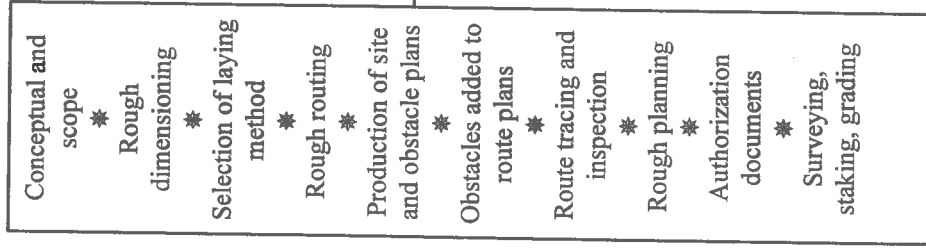

### Phase 2

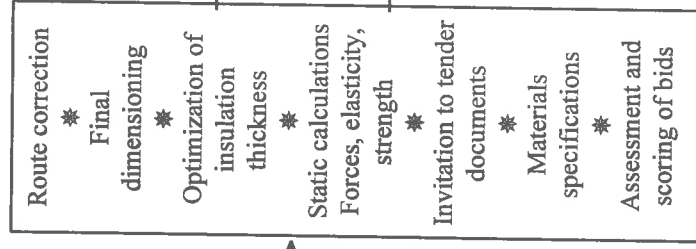

### Phase 3

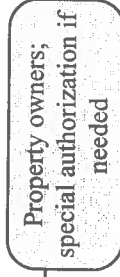
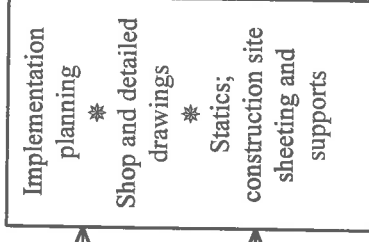

### Phase 4

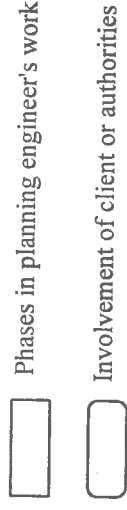
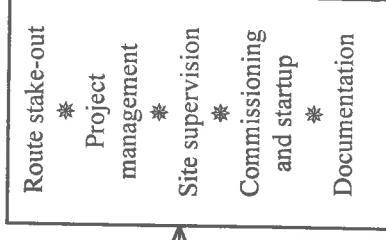

Figure 7.1.1-1: Steps in planning construction of district heating lines [based on 40]

### 7.1.2 Market Aspects

In order to achieve the lowest construction costs full advantage must be taken of the possibilities offered by a free market in construction work. Naturally, efforts should be made to reduce costs through cheaper technical solutions, but in so doing one should not lose sight that a cost-conscious business-like approach can often achieve even greater savings.

Construction of a pipeline system involves various trades. The client enlists the help of a planner and delegates implementation to an excavation firm and a pipeline builder. Materials may be obtained directly from the manufacturer. To take full advantage of market potential each participant must be employed in line with his field of expertise while avoiding overlap between participants. Conflicts of interest are to be avoided at all cost. While they may hold the prospect of short-term advantage, their effect is harmful in the long term, as can be illustrated from numerous examples. One such example is the importance of separating the work of the planner from that of the supplier. If a supplier is entrusted with responsibility for planning, there is an acute danger that construction decisions will favour his product. The same holds true for other points of conflict.

The advantages of the market are:

- ◆ Competition

The greatest market potential lies in competition. If the client sets out clear specifications for the job, he can obtain competitive offers and select the best one.

- ◆ Quality

The choice of high-quality materials ensures long-term operational reliability, low operating costs and a long service life

- ◆ Materials procurement by client

Direct procurement of expensive building materials from the manufacturer coupled with the purchase of large quantities through the supplier can be advantageous.

- ◆ Making use of special factors

The use of new and improved structures, components and materials and taking advantage of special opportunities that often arise in the market introduction of new manufactured products (assuming quality is not jeopardized) can allow for savings.

Over the years of system construction and expansion a close working relationship will normally form between a supplier and a few capable subcontractors closely associated with the supplier. In such cases it should be verified from time to time whether these firms' prices remain competitive.

The work of participants in a construction project is regulated by contracts. The possible structures of contract relationships between the client and his partners is shown in Figure 7.1.2-1. Responsibilities with respect to the work guarantee are similar.

In order to prevent a splintering of responsibility that may lead to delays and disputes, it has proven beneficial in dealing with suppliers to bind all firms participating in the construction in a joint liability and guarantee arrangement.

Two special points in district heating project contracts relate to the guarantee and the collective contracts for small projects - the so-called one-year contracts.

**EXAMPLE 1**

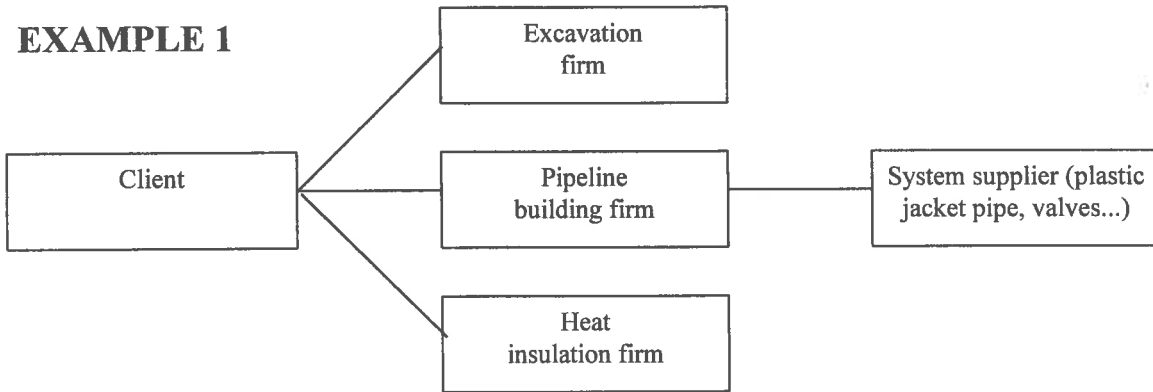

**EXAMPLE 2**

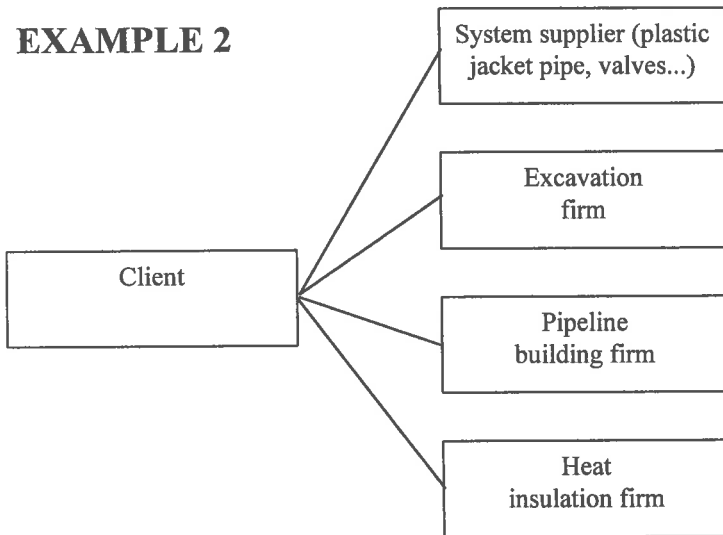

**EXAMPLE 3**

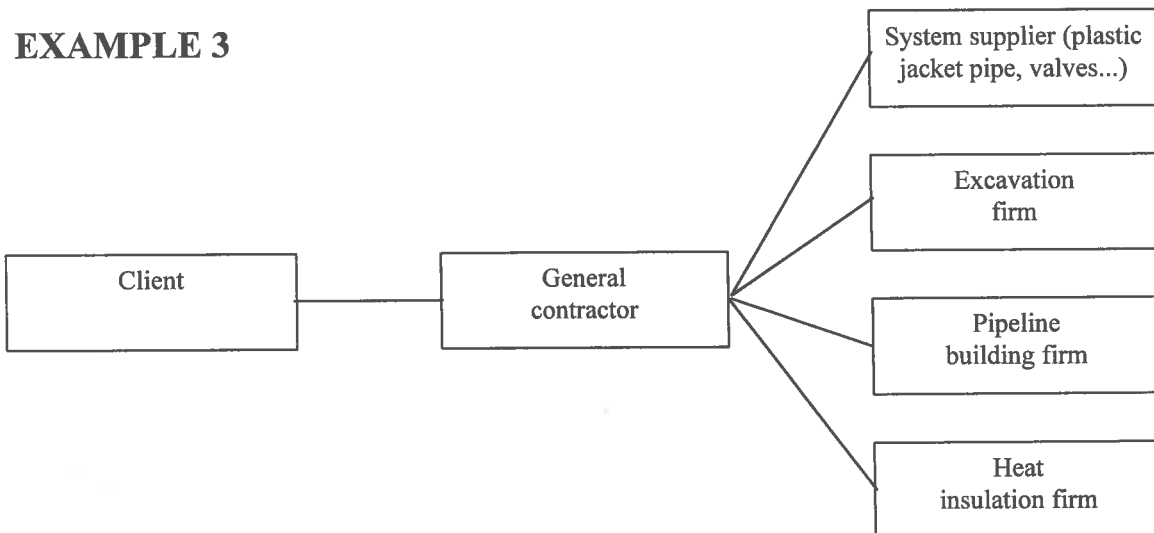

Fig. 7.1.2-1: Contract relationships in engaging and guarantee

The guarantee covers only the financial consequences of defects. It is no substitute for quality in the planning and construction of pipelines.

Responsibility for formulating conditions of the guarantee generally lies with the client and forms part of the order. The length of guarantee is subject to negotiation. In view of the long service life of district heating lines it should cover a period of five years.

The guarantee should be formulated in such a way that lines of responsibility are clearly drawn for the system supplier, excavator, pipe layer, monitoring system manufacturer, sleeve installer, and others.

The guarantee must encompass not only the replacement of defective parts or installations but also the necessary costs of locating the defect and the costs of consequential damage (excavation, recultivation, etc.) to the extent these are directly associated with the assessment and removal of damage.

#### **One-year contracts:**

To simplify dealing with the numerous small construction sites handled over the course of a year, the supplier usually concludes contracts covering a number of subcontractors. These contracts indicate the estimated order volume for a calendar year for all the construction sites. Delivery of goods and services are then requested as needed from the subcontractors at agreed prices. Unforeseen difficulties on the construction site or cost overruns under multi-year contracts can be compensated for by contingency allowances.

### 7.1.3 Project Management

The demands of project management must be viewed in light of the scope of the project. A small job that can be completed in a single or several days requires a supervisor but no organized management. In contrast, construction of a large transmission line, which can take two years and require a substantial investment of materials and personnel, demands the involvement of an entire team of project managers, and their work must be organized effectively. Here follow some suggestions regarding the management of large projects, from which the reader can determine for himself what is required in his case.

Project management must record and monitor:

- ◆ Timing and deadlines
- ◆ Costs
- ◆ Resources.

Not only deadline monitoring but also cost control is important since, with long-running large-scale projects in particular, there is a risk of an unacceptable rise in construction costs in the course of the project.



Project management not only involves control functions but must also ensure smooth cooperation among all participants by means of an appropriate flow of information.

A key task of project management is the breaking down of large projects into manageable elements: construction jobs, route segments, trades, etc. The necessary parameters, such as construction time, costs and materials, are then matched with these elements. Network planning techniques have proven especially valuable in representing these relationships. There are a number of computer software programs that make it possible to produce and work with charts of this type and to manage large quantities of data on a personal computer.

The individual project phases outlined in Figure 7.1.1-1 can be handled by such networking charts in varying degrees of detail, as required.

The main principles that a project leader or project team must lay down for project management are:

- Determining which client departments, planners, subcontractors, authorities, testing facilities, experts, etc. are to be involved in the management system.
- Clarification of plan parameters, such as deadlines, construction time, materials requirements, funds.
- Degree of detail.
- Time intervals for monitoring. The tightness of control should not only be based on a frequent use of information but should also take into account the expense of repeated data gathering. The data gathering must be organized to be as synchronous as possible at all points and close to the time of reporting so that reports reflect reality as closely as possible.

For large construction endeavors minimum reporting intervals of one month may be chosen.

- In establishing the flow of information it must be decided what information is to be included and in what volume; the locations (persons) to which reports go and, possibly, the path reports are to follow should be indicated.

From these remarks it will be clear that the management of large projects requires a substantial investment of work and organization. Software tools can efficiently handle many of these tasks.

But the main goal of project management is to instill a positive attitude toward monitoring among the project participants. The participants must accept monitoring in the conviction that a large project cannot be completed within the allotted time and cost restraints without ongoing control measures.

The hydraulic design of a district heating system depends on a multitude of factors. The main factors for design are

- Maximum heat load
- Temperature difference (supply-return pipe)
- The distance from the heat plant to the farthest customer

All of these factors will influence the pressure difference and the diameter of the pipes. In addition choices have to be taken which will influence on hydraulic design.

### 7.2.1 Water circulation

#### PRESSURE DIFFERENCE

The maximum heat load is driven by the customers, and so is to a certain extent the temperature difference. The temperature difference is given by the maximum temperature the district heating pipes are designed for and the customer's return temperature at maximum load.

In addition the following factors and choices made in design will influence the hydraulic and pump design. These are:

#### **Coincidence factor**

Due to the fact that not all of the customers have their peak load at the same time, the maximum load at the heat plant can be reduced compared to the sum of the maximum loads of the customers, usually by a factor of 0,7-0,9. This will depend on the number and type of customers. The more customers and the more different types of customers the lower the factor. This will also influence to some extent the diameter of the pipes, especially the larger dimensions.

#### **Customer's equipment and conditions.**

The most important thing is to achieve as low a return temperature in the customer's system as possible. For new buildings it is important, for example, that the ventilation system is designed for water temperatures 80°C -40°C and not 80°C-60°C. It also is very important to have no bypasses from the supply pipe to the return pipe, which will increase the return temperature unnecessarily. Especially it is important to be aware of this factor when connecting older buildings with heat boilers, who usually prefer bypassing from the supply pipe to the return pipe through the boiler.

#### **Heat exchanger Design**

In systems with heat exchangers it is preferable to have small temperature differences between the return temperature of the customer's system and that of the district heating system. The extra cost for a lower difference, for example 2°C-5°C, which will require a larger heat exchanger, in most cases is small.

Pressure drop over the customer's station, consisting of a heat exchanger, regulation valve, filter, heat meter and other equipment is usually set to about 100 kPa, which means, this is the minimum pressure drop any customer shall have available over his station.

#### **Supply temperature in district heating pipe.**

The temperature depends on the type of insulation, but preinsulated pipe construction usually limits the temperature to 120°C. In regard of heat loss and pumping costs the temperature usually is varied in connection with outside temperature down to a minimum of about 70-75 °C. This temperature is due to the domestic hot water treatment of the customer.

#### **Pressure drop, velocity**

The velocity in district heating pipes varies with the diameter, usually between 1-3 m/s, sometimes more. The bigger values for the bigger diameters, the smaller for the smaller. In main pipes one usually has a design pressure drop of about 100 Pa/km, for smaller branches maybe 250 Pa/km. To a certain degree this is depends on the extent of the pipenetwork.

#### **Pipe dimensions**

From the parameters given above and limitations the pipe diameters have to be calculated.

#### **Heat plant**

In the heat plant there will be equipment that causes extra pressure drop, such as heat exchangers, filters, heat meters, regulation valves and a greater number of pipe bends. This will vary from heat plant to heat plant.

Regarding the above parameters the hydraulic designs can be made. It can be calculated by hand or by computer programs. Computer programs give a much better opportunity to optimize the district heating system in regard to limits and costs.

A district heating system may have one or more heat plants, and in addition booster utilities placed elsewhere in the pipenet. Which solutions are to be chosen will depend on the district heating system in each case. Fig. 7.2.1-1 and 7.2.1-2 shows example of pressure diagrams for different solutions.

#### **Regulation of pressure difference**

Regulation of the pressure difference must be done in regard to which customer is having the lowest pressure difference, or needs the highest pumping pressure. There are different ways of regulating the pressure:

##### **Fixed rpm with throttling valve**

The pump will use unnecessary amount of electricity

##### **Manual rpm regulation**

Will take care of the flow and pressure drop variations to a certain degree when an operator is present.

#### **Automatic rpm regulation**

The pump is governed by the customer having the highest demand for pumping pressure. This may vary, so several customers can be chosen to govern the pump. The one with the greatest demand is automatically chosen to govern the pump at any time. The sensors measuring the pressure difference should be located so that they will not be shut off when shutting off the customer. A place on the main- or branch pipes in the neighbourhood of the customers is recommended. Fig. 7.2.1-3 shows a sketch of principle to automatic rpm regulation of pumps.

There will be limits to pump regulation in regard of the highest and lowest pressure permitted in the system. This may be solved by pressure sensors which have priority in governing the pumps when the pressure limits are surpassed.

Special cases to be taken care of are:

#### **Pump stops abruptly**

This can cause pressure waves which can lead to too high pressure in low elevation parts of the net and too low pressure in high elevation parts of the pipe system. The last may cause boiling in the system which may lead to very hard pressure fronts when the steam collapses.

#### **Valve opening and shutting**

Opening and especially shutting a valve too abruptly will cause pressure waves when the pumps are running. Especially in large diameter pipes it may be necessary to calculate and try out the shutting and opening velocities in regard to pressure waves, and maybe it will be necessary to slow down the pump speed when operating the valves.

#### **Securing the pumps for low inlet pressure**

Especially if the pump is placed at a high elevation in the district heating network it may be necessary to secure the pump with a pressure sensor against low inlet pressure caused by rpm values which are too high, or if a valve on the return side of the pump is closed. In the same way it is wise to secure the pump against shut valves on the forward side with a temperature sensor.

#### **Securing special parts of the net for damages**

In using railway right of ways, for example, it may be required to use automatic shutoff valves to protect the railway from water if the pipe should suffer damage.

### **DIAMETER OF PIPES**

Diameter of pipes may be calculated manually or by computer programs. A computer program gives the opportunity to optimize the district heating net much better in regard of netcosts, pump costs, pressure and pressure limits and what if scenarios in regard to

Diameter of pipes may be calculated manually or by computer programs. A computer program gives the opportunity to optimize the district heating net much better in regard of netcosts, pump costs, pressure and pressure limits and what if scenarios in regard to

changes in the future, for example increases in load. Practical things to have in mind when considering pipe diameters are:

- Coincidence factor when summarising the maximum loads
- Future loads
- Pipe costs for extra capacity

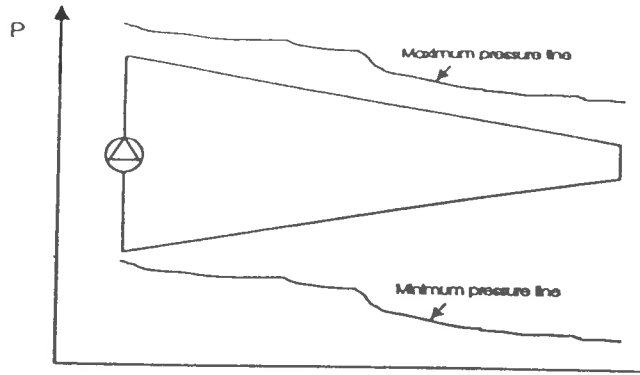

Figure 7.2.1-1 District heating system with one heatplant

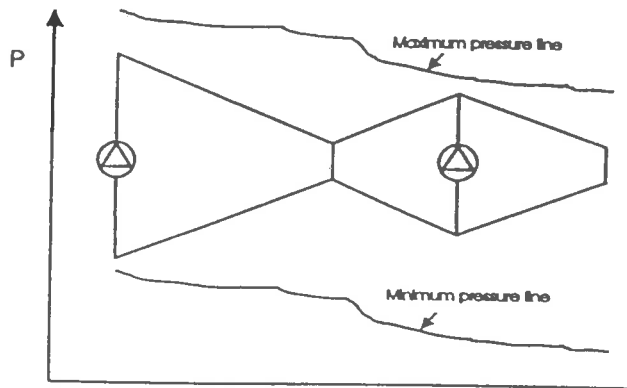

Figure 7.2.1-2 District heating system with two heatplants

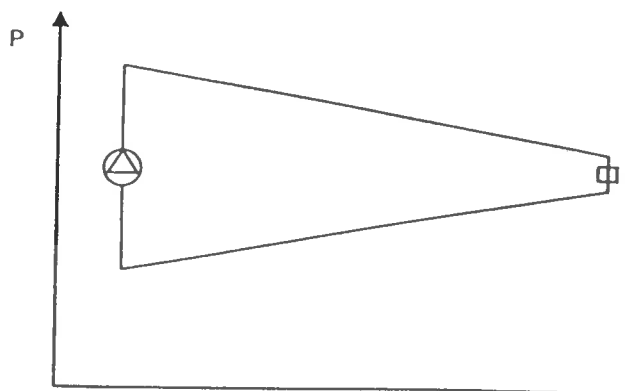

Figure 7.2.1-3 Pump with automatic r.p.m regulation governed by difference pressure of customer

## 7.2.2 Pressure maintenance

The pressure maintenance system shall keep a certain pressure at a reference point of the district heating system. Variations in pressure at the reference point are caused by:

- Changes of the water volume caused by changes in the water temperature
- Variation of pumping pressure
- Leakage in the district heating system

By keeping a certain pressure at a reference point it is possible to prevent too high pressure in a low elevation part of the network and too low pressure with possibility of boiling in the high elevation part of the network. This usually is done by regulating the amount of water in the district heating system.

### TYPES OF PRESSURE MAINTENANCE SYSTEMS

#### **Open reservoir**

This is a system used in some district heating systems. The reservoir has to be located at a level corresponding to the pressure required at the reference point. The system does not give much opportunity for changes in system pressure when the system is built.

#### **Closed reservoirs with a gas blanket**

These are usually used in small systems, for example a group of buildings.

#### **Closed reservoir with steam blanket**

This gives much better flexibility in volume changes than a system with gas blanket. In addition it can be combined with storage which gives the possibility of storing energy during periods with low demands, for example at night, and use it during periods with high demand. With a low steam pressure the reservoir has to be situated at a level corresponding to the level in the reference point. With high steam pressure one is more free to locate the reservoir, and to regulate the pressure level.

#### **Pressure maintenance system with pumps and overflow valves**

This system has the greatest degree of freedom as to where it may be located and to what pressure level is required. The pressure pump reservoir may be either open to atmosphere or it can have a low pressure steam blanket. It also may be combined with water treatment. Figure 7.2.2-1 shows a principle sketch of a pressure maintenance system with pumps and overflow valves.

The pressure maintenance system is located usually in or in association with one of the heat plants. It is important there is only one pressure maintenance system in the district heating system. If there is for example two systems the result will be that one is pumping water into the system, the other letting it out of the system. If there is a wish to have two systems placed differently in the net it is necessary to have the same reference pressure point, and the systems working in connection with one another. For example, when one system cannot manage to pump enough water into the system the other will help. This is done by connecting all pumps to the same pressure point, but the starting pressure of the pumps is different. So, in reality it is one pressure maintenance system, but the pumps are located in different places. It does not matter where water is let in or let out of the district heating system. What is important is the location of the reference point (the point of constant pressure).

When choosing the reference point be aware of the limits of the system. Also it is necessary to make an analysis of "what happens if...". The main thing to consider is what happens if the circulation pumps stop.

Figure 7.2.2-2 shows a pressure diagram for the pumps, pressure maintenance before the pumps and the pressure limits represented by the two curved, parallel lines. The bottom line may be said to represent the ground level, or atmospheric pressure, the top level maximum pressure, for example 1.6 MPa at design pressure PN 16. If the circulation pump stops the pressure diagram is represented by the dotted line. The system can handle this situation. Neither the maximum or the minimum pressure line is crossed.

When the circulation pump runs it is important that there are enough margins between the minimum and maximum pressure lines. The margins are often required to be 0.1-0.3 MPa depending on the system and where in the system they are. The atmospheric line represents boiling at 100 °C. If the forward temperature is 120 °C the boiling point will be 0.1 MPa *above* the atmospheric or ground level line.

Figure 7.2.2-3 Shows the same situation, but the reference point of the pressure maintenance system is located after the pump. When the pump stops the lower elevations of the district heating net will have too high a pressure, the dotted line crosses the maximum pressure line. Generally, if the heat plant and reference point is located in the higher elevations of the net, the reference point should be on the suction side of the pump, and near the pump to take care of pressure loss in the plant. If the plant with the reference system is located in the lower elevations of the district system it should be on the pressure side of the circulation pump.

It is also possible to let the reference point be the middle of the pressure on the pressure side and the suction side of the pump. Figure 7.2.2-4 shows the pressure diagram for two different pump-heights of the circulation pump in this case. The dotted lines show the pressure diagram when the reference point is located before the circulation pump, after the pump and as a mixture of the pressure before and after the pump. This solution may be arranged with pressure pumps and overflow valves, but will be hard to obtain with other systems. However, the solution should only be used if absolutely necessary. If the pressure



maintenance system should have a failure the pressure limits may be overrun when the circulation pump stops.

The parameter for diameter the pressure maintenance system mainly is the volume change of the water in the district heating system. In addition comes leakage and refilling of pipes when the pipes has been emptied.

Volume changes is due to temperature changes of the water. This occurs when:

Outside temperature is changing. The setting point of the forward temperature will be changed, and the return temperature will be influenced.

More or less effect is put into the system than required from the customers. This may happen after a stop in deliverance, bypasses set open in the system and other irregularities.

Pipes has been emptied and filled up, and the water needs warming up. This usually will be the largest demand. The important thing is for how long time the customer can be without heat. To be taken into consideration is time for emptying and refilling pipes, reparation of the damage, warming up the water and which amount of water is to be warmed up. It for example means to take into consideration the largest volume between two shutting valves. It also have to be taken into consideration that other parts of the net may have been cooled down.

When heating up or cooling down water only the **effect** of the heating or cooling will determine the capacity of the pressure maintenance pumps and the overflow valves. The water volume only will have influence on the reservoirs of treated water.

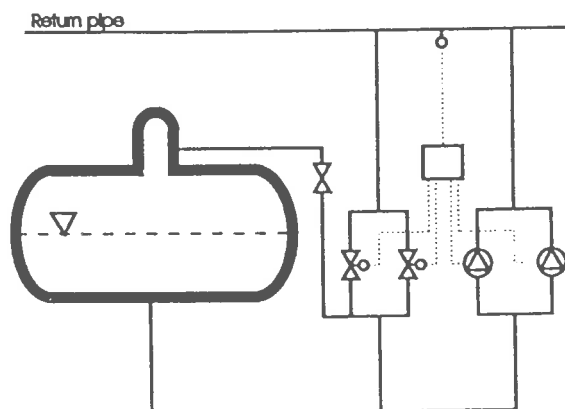

Figure 7.2.2-1 Principle sketch of pressure maintenance system with pumps and overflow valves

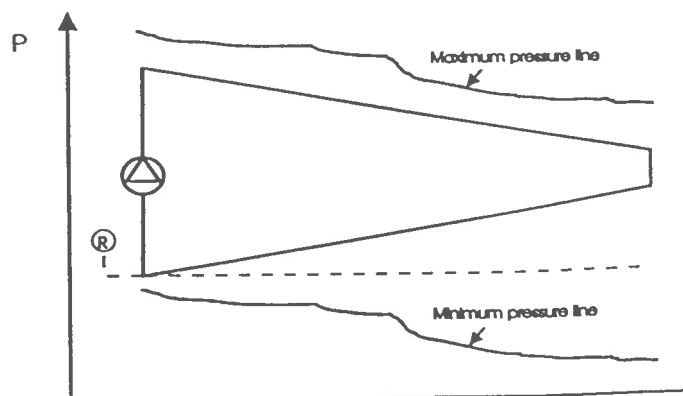

Figure 7.2.2-2 Pressure maintenance. Reference point before the pumps.

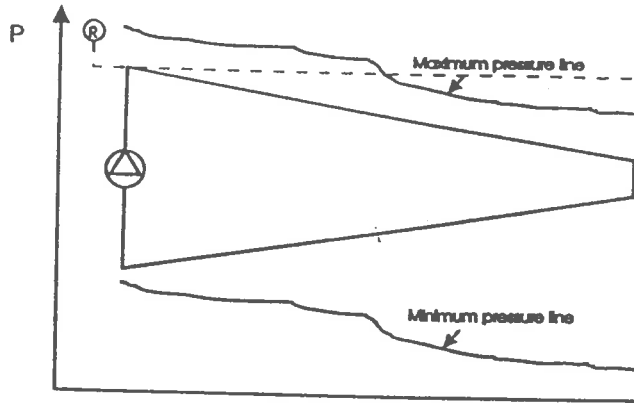

Figure 7.2.2-3 Pressure maintenance. Reference point after the pumps.

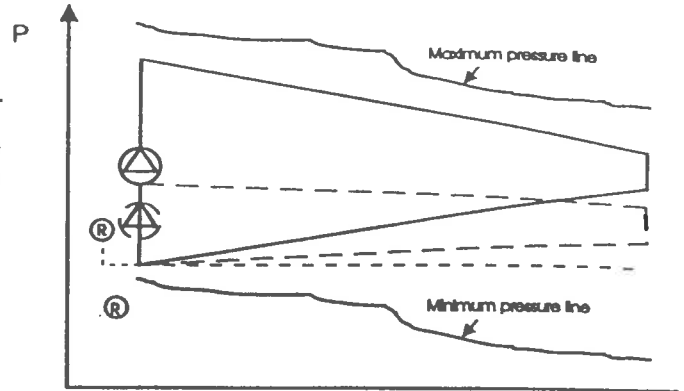

Figure 7.2.2-4 Pressure maintenance. Reference point before the pumps. Different pumping heights.

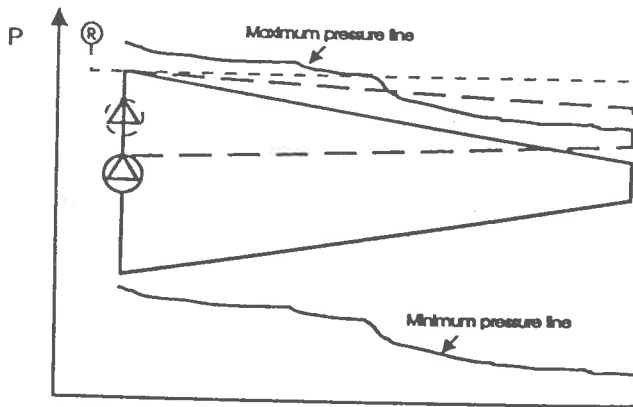

Figure 7.2.2-5 Pressure maintenance. Reference point after the pumps. Different pumping heights

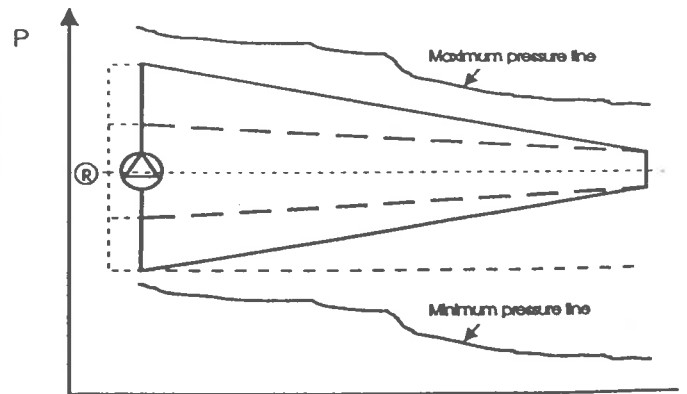

Figure 7.2.2-6 Pressure maintenance. Reference point before and after the pumps.

### 7.2.3 Design of pumps

When designing the pumps the following parameters have to be taken into consideration:

- Pumping height
- Flow
- Temperature difference
- Design pressure
- Minimum suction height
- Pressure shock

#### **Pumping height**

Maximum pumping height is set by the pressure loss in the pipes at maximum flow, minimum pressure difference for the customer and pressure losses in the heat plant.

#### **Flow**

Maximum flow is set by the maximum coincidence effect and supply and return temperature.

#### **Temperature difference**

Maximum temperature difference is set by the maximum supply temperature, which depends on the type of pipes used and the customer's return temperature and, if the customer has a heat exchanger, the size of the heat exchanger.

#### **Design pressure**

Design pressure is set by the maximum pressure that may occur in the system and usually is the same as the design pressure of the pipelines and other components. It is very important to have in mind that although the pumps have been tested with a higher testing pressure than the design pressure from the producer, *they must not be exposed to the testing pressure of the pipelines after being installed*. This is due to the pump seals which normally will not withstand the pipeline test pressure.

#### **Minimum suction height**

To prevent boiling in the pump there has to be a minimum suction height before the pump due to pressure losses on the suction side in the pump. The temperature here has to be taken into consideration. The suction height is the minimum height needed over of the pressure at the boiling point.

#### **Pressure shock**

The material must be capable of withstanding pressure shocks in the water system. The material of the housing therefore should be of steel or nodular cast iron (GGG) and not of ordinary cast iron (GG) which may crack easier when pressure shocks occur. Corrosion usually is no problem with treated district heating water.

The pumps may be located either in the forward pipe (after the boilers) or in return pipe, or in both. Figure 7.2.3-1 shows the principle of pump location.

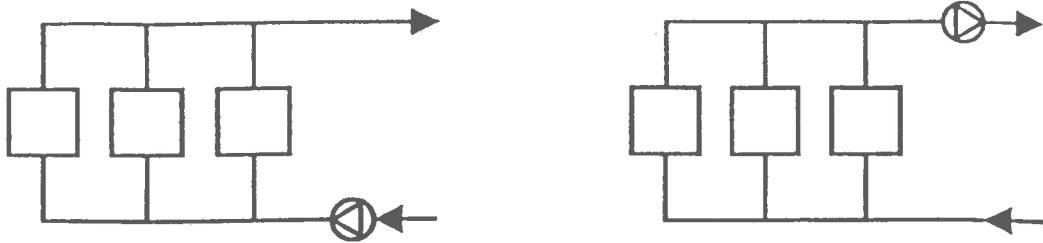

Figure 7.2.3-1 Principle figure of pump location

The number of pumps depends on the size of the heat plant and district heating system. It is of course necessary to have pumps in each heat central to deliver heat, and in addition there may be pressure boosting stations in the district heating network. The minimum number of pumps in a heat plant should be two due to the fact it is necessary to have a spare pump. If each should be 100 % in volume capacity has to be considered, but it will give a good security and is often common for smaller plants. For bigger plants 3 pumps of 50 % may be used, or for example four pumps of 33 %. If there is pumps in both return and forward pipe the pumping height is to be divided between return and forward pumps, but the pumps of course must be designed both in return and forward pipe for the total flow.

To prevent damage to the pump and picking items and particles out of the water it is recommended to have a coarse filter in the pipeline before the pump. Especially this is useful when starting up with new built pipeline stretches. It then can be useful to strengthen the filter with bars. The filter must not be too fine, then the pressure loss will be too big and the filter threads may burst. To remove small particles as magnetite it is recommended to have a small stream through a very fine filter in parallel to the main pipeline.

To prevent damages on the pump and net it can also be recommended to install other types of security equipment.

A temperature feeler in the pump at the outlet which stops the pump at too high temperature will prevent the pump to get too high temperature, or that the water in the pump starts boiling. This may occur if the forward valve of the pump is shut. The customers then will demand more flow, and the pump will speed up and the water in the pump start boiling if there is no security installation.

A pressure feeler in the suction pipe of the pump which stops the pump at too low pressure will prevent the pump to get too low pressure which may result in boiling and damage of the pump.

The most common pump regulation is the regulation of the rpm of the pump. To control the flow and pressure of the pump difference pressure sensors may be installed in different points in the network. The lowest difference pressure then will regulate the pumps. Which point will have the lowest difference pressure will change due to the situation in the network.

It also may be wise to install pressure sensor in the lowest and highest part of the network. If the pressure is close to the pressure limits these signals can overrule the signals usually used to set the flow of the pump.

To prevent water flowing backwards in the pump and causing the pump to turn the wrong way if there is automatic start and stop of parallel pumps, it is recommended to install a back flow preventer valve in the supply pipeline of each pump.

The working area of the pump is shown in a pump curve. Figure 7.2.3-2 shows a typical pump curve for a district heating pump.

The pump curves show the connection between flow and pumping height at a certain rpm. The various pumping curves show the connection at various rpm. The efficiency lines show the efficiency at the different points of the pumping curves. When at the pump diameter the diameter point should be at the best possible efficiency. The greater the flow at constant r.p.m, the greater is the need of power. This is to be observed when at the pump diameter. If the pressure drop in the pipelines is not as big as calculated the pump may need more power at maximum rpm than calculated.

Figure 7.2.3-3 shows a pump characteristic together with a network-characteristic. The network characteristic is represented by the dotted line. When regulating the pump to a lower flow with rpm regulation the pumps flow-pressure connection will follow the dotted line and usually give the best efficiency possible at lower rpm. Figure 7.2.3-4 shows a pump with constant rpm regulated to lower flow by throttling. The network characteristic then will change into an area where pump efficiency is less, and may cause unnecessary high pressure and pressure difference in parts of the net.

The efficiency curves of the pump are shown in the figure 7.2.3-3. In the best points it amounts to about 80-85 %, the rest is losses. However, most of the loss is transferred to the water, so in reality it is not lost. But the price of this energy will be the price of the electricity which usually is much higher than the price of the energy used in the boilers. So it is important to have as small pump losses as possible. The loss in the motor mostly amounts to about 2 % depending on the load. Usually it is lost to the air and will be lost if the air is not used in a boiler.

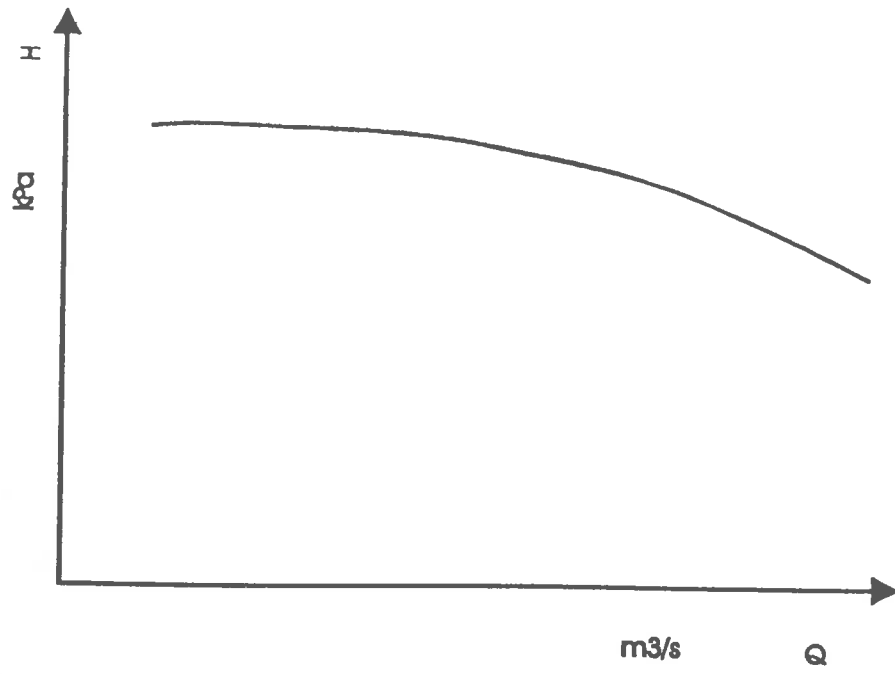

Figure 7.2.3.2 Pump curve

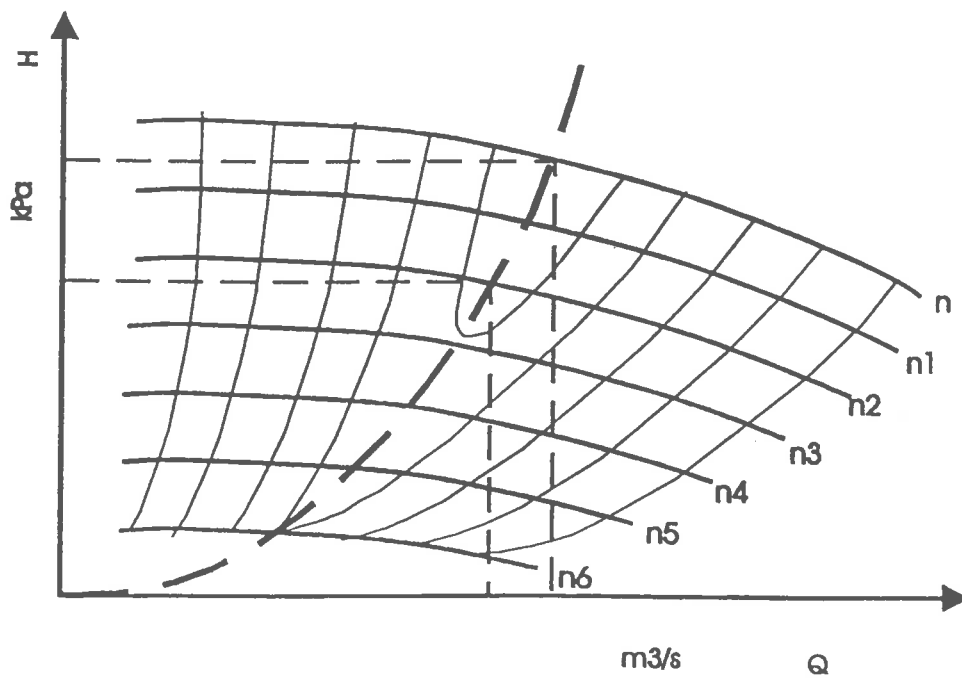

Figure 7.2.3.3 Pump curve with netcharacteristic. R.P.M regulation

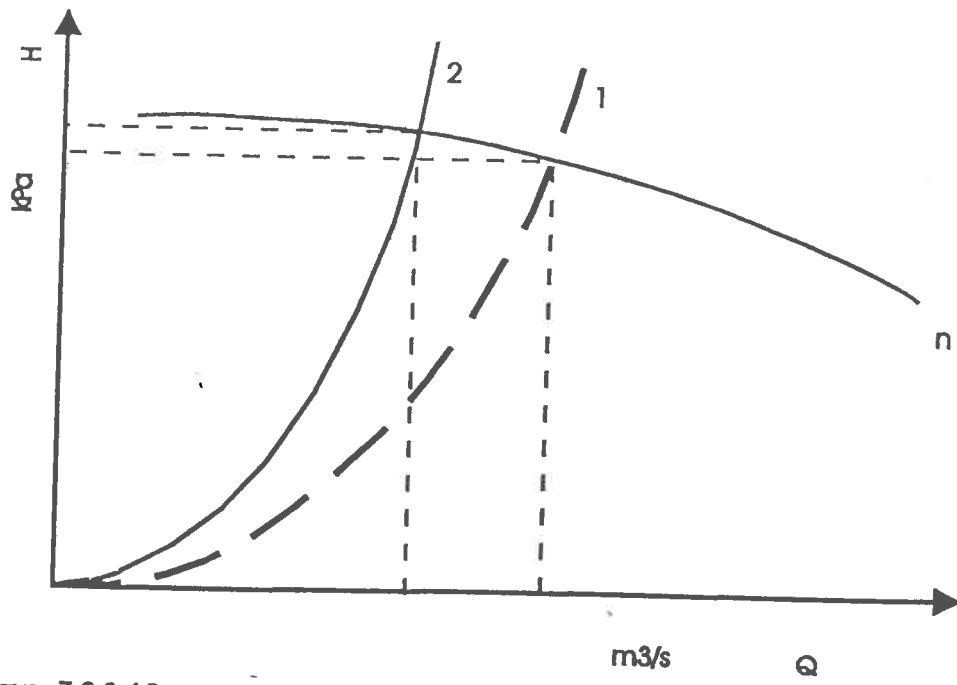

Figure 7.2.3.4 Pump curve, pump regulated by throttling

#### 7.2.4 Pressure Boosting Stations

With bigger district heating nets it may be necessary to have pressure boosting utilities in the pipelines outside heat plants. This may be done for the following reasons:

To avoid too high pumping height in one place which may cause problems with the pressure limits

To better adjust the pressure in the system to the geography

To reduce the pumping energy to a minimum. If only a minor part of the customers needs high pumping height, it is not necessary to give the total flow this pumping height.

The pump size will be influenced by the total coincidence effect of the customers and the other parameters mentioned earlier.

The boosting utility may be located in the supply or the return pipe, or in both. Which location to choose depends on geography and pressure condition. It will be useful to plot a pressure diagram to see the effect of the location in different situations. Figure 7.2.4-1 shows a principle flow chart of a pressure booster utility.

Figure 7.2.4-2 shows a pressure diagram for a booster utility located in the return pipe. In this case it is important to ensure that customers in the neighbourhood of the booster utility have enough pressure difference between forward and return pipe. The best way to take care of this is to regulate the booster pump in such a way that it keeps the pressure difference between forward and return pipe constant just after the pump on the pressure side.

If the pump is located in the supply pipe, the constant pressure difference has to be measured on the suction side just before the pump. As the main pumps are usually rpm regulated it is preferable to use a similar scheme that will follow the main pumps. It is also wise to safeguard the pumps against too high a temperature and high and low pressures. Filters should also be installed.



PUMPESTASJON TØYENHAGEN

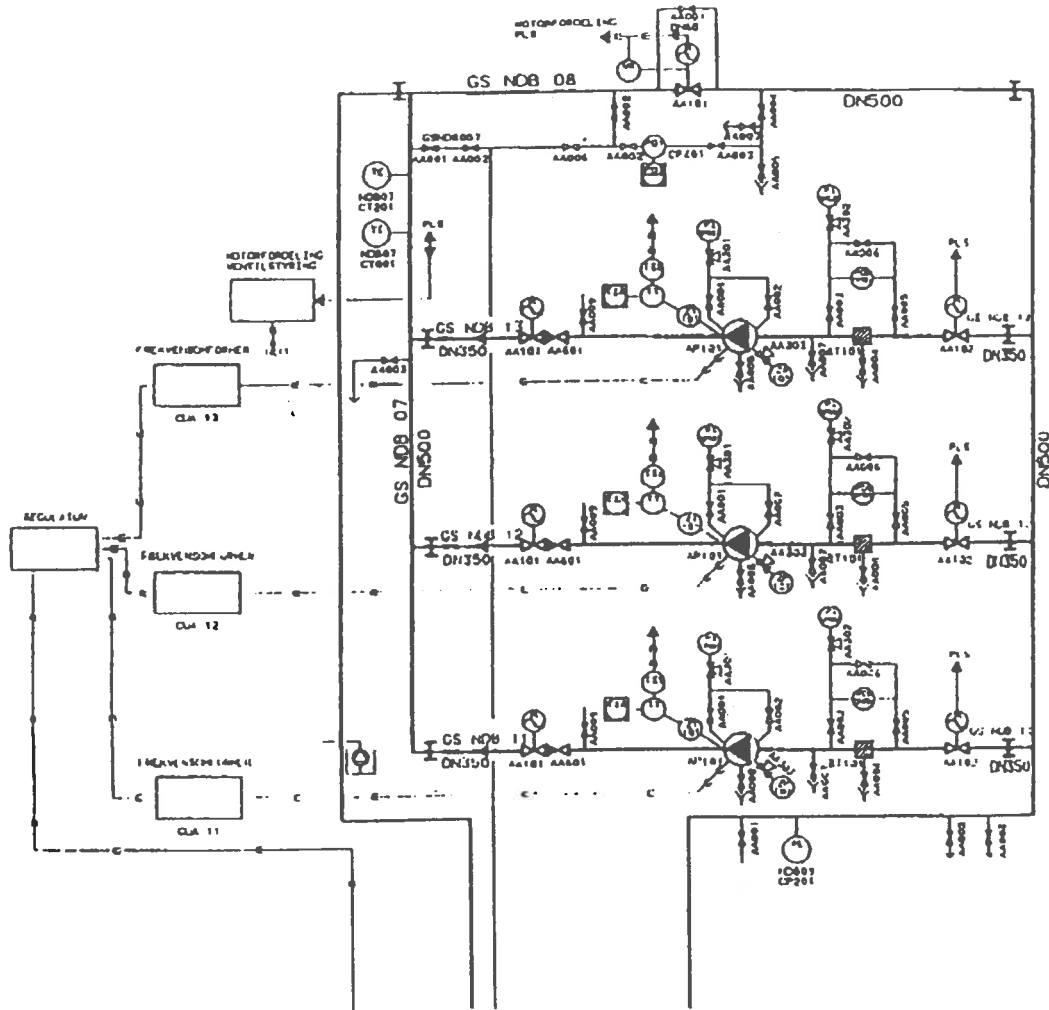

Figure 7.2.4-1: Principle flow chart of pressure booster station

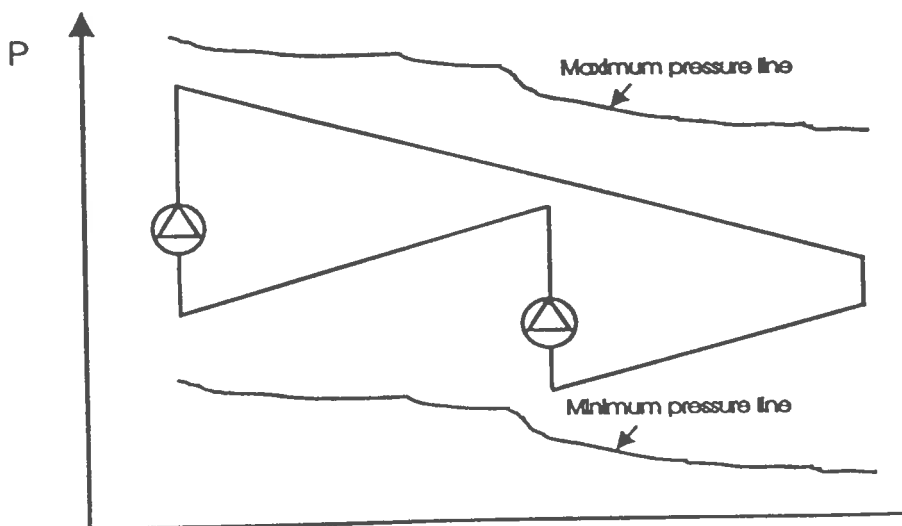

Figure 7.2.4-2 District heating system with one heatplant and booster station.

### 7.3 Statics

On the subject of structural calculation of district heating lines there is, in addition to the standard literature, a series of special publications [26, 12, 44] as well as specialized software [25]. These tend to focus on calculations for plastic jacket pipes since this construction system demands a particularly careful design. The main issues involved are described in Section 8.1.1.

Two special issues of statics - design against materials fatigue and bearing friction - are dealt with below.

#### 7.3.1 Design Against Fatigue Failure

In certain structural calculations it has been shown to be advisable and, at times, unavoidable to assume both dead loads and vibrational loads. This means calculating not for yield strength but for fatigue strength. Computational situations of this type arise both for plastic jacket pipes as well as for compensators. The engineer performing the calculations must adopt assumptions regarding the number of stress cycles during the life of a line.

District heating lines undergo a large number of stresses of small amplitude but very few of full amplitude, such as might result from a slow shutdown. (Exceptions are possible!) A basis for standard design has been established in a number of district heating studies [26, 44] and a comprehensive analysis is underway in Sweden at this time [43].

The reference value assumed today for a standard design is 100 to 200 full amplitude stress reversals over the entire life of a line (partial amplitude reversals converted to full amplitudes). The future will show whether this value for transmission mains is too high or whether, for certain service lines, this number of stress reversals is perhaps too low.

In the absence of any new results to the contrary, the assumption of stress cycle values of  $N=100$  to 200 seems appropriate for the design of lines with a normal temperature regime.

### 7.3.2 Friction in Pipe Bearings

Systems with plastic jacket pipes also have pipe supports and anchor points, such as at line utilities, in shafts, on aboveground line sections, etc. The anchor point forces are determined from the friction forces in the pipe bearings.

Friction forces are calculated using the friction coefficient for the corresponding bearing materials pairing. Experience has demonstrated that the friction coefficients commonly employed in machine building are too low for district heating lines. For the special conditions (dirt, rust, short and slow movement) of pipe supports the comparatively high values in Table 7.3.2-1 should be assumed.

Materials pairing	Friction coefficients
Steel/steel	0.5
Steel/ fiber cement	0.6
PTFE/stainless steel, dirty	0.4
PTFE/stainless steel, clean	0.1
PTFE/stainless steel, measured values	up to 0.2
DV roller supports/stainless steel, dirty	0.2
DV roller supports/stainless steel, clean	0.1
Polyamide/concrete	0.6
Polypropylene/steel or cast iron	0.6

Table 7.3.2-1: Friction coefficients for pipe bearings in district heating lines

#### 7.4 Economic insulation thickness

In addition to the global values discussed in Section 5.4 regarding system losses, something should now be said about selecting the economic insulation thickness for a line. The economic insulation thickness is defined as the thickness that results in the lowest overall cost for the line.

A complete consideration of costs associated with heat insulation should not be restricted exclusively to the cost of the insulating material but must also draw in those components of construction costs that derive indirectly from the thickness of the insulation, such as the material excavated to provide a wider trench. The costs of heat losses must also be examined. The cost consideration must cover the entire useful life of the line and so include increases in energy prices and construction costs. Such a calculation is very laborious and to date has seldom been undertaken to this extent.

Manufacturers offer three series of insulation for plastic jacket pipes, that is, piping with three different thicknesses of insulation. The planner must make the most suitable selection. But in some situations the client can specify any desired insulation thickness without supplier restrictions. This becomes possible in the case of aboveground lines, in-duct laying and in large projects with plastic jacket pipes when the quantity ordered is large enough to justify special dimensions.

In engineering practice optimization calculations are always performed for transmission mains. Usually the thickness actually provided by the supplier is more generous than the calculated amount rather than less.

Some of the key variables that are used in optimizing insulation thickness are:

- physical quantities for calculating heat losses
- costs associated with pipeline construction
- heat costs
- capital market developments
- service life

Figure 7.4.2-1 shows the results of calculations for the flow and return lines of a particular pipeline system; the price of heating is used as a parameter. For the return line there were, on average, fewer optimum insulation thicknesses, although the variance in the decisive cost factor, the capital value, between flow and return lines was only  $\sim 1\%$ . For this reason, the supplier decided to simplify on-site work and storage conditions by employing the same pipe material for both flow and return.

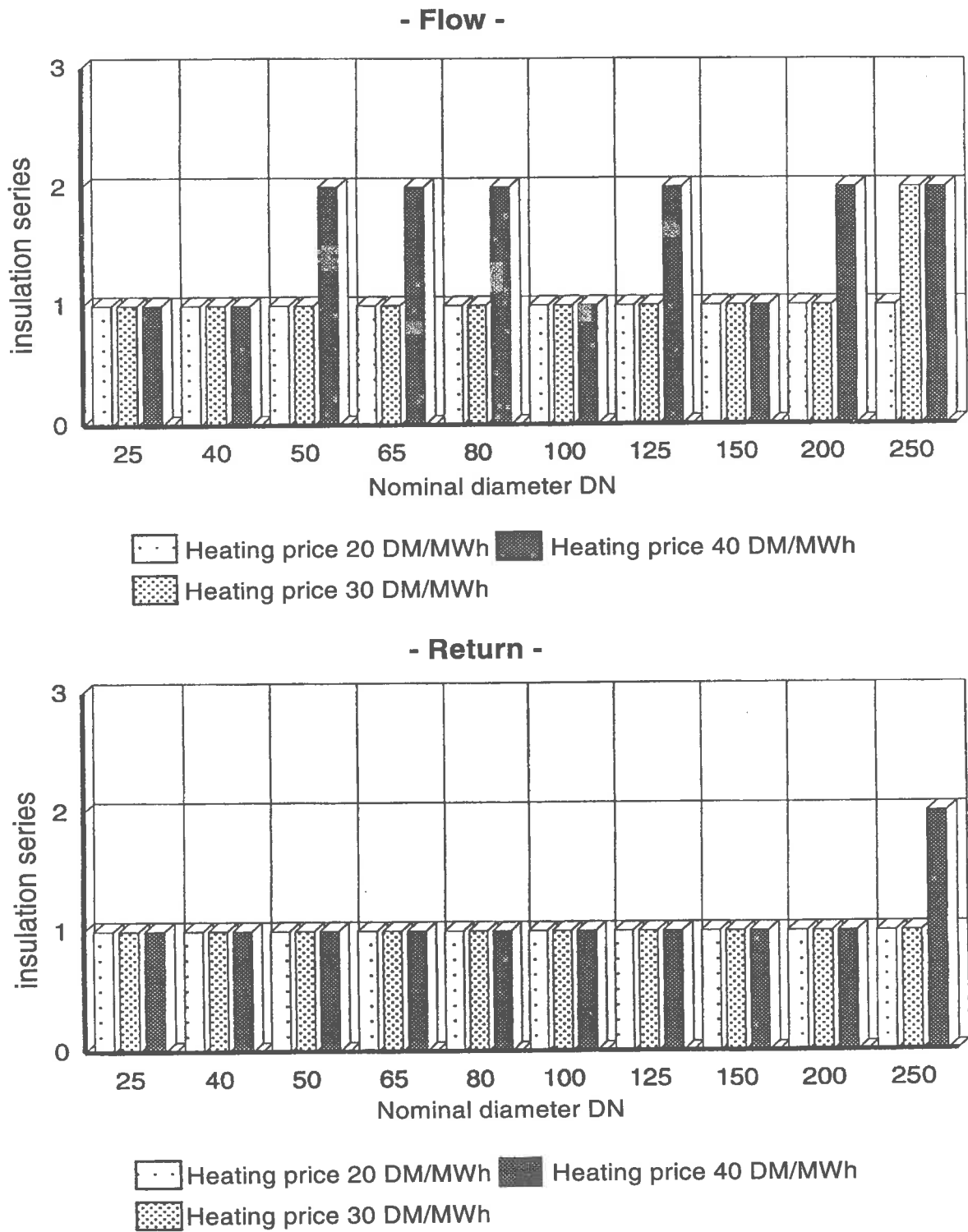

Figure 7.4.2-1: Optimum economic insulation thickness for district heating lines.

## 8. Pipeline Laying Methods

The preferred method for laying district heating pipelines is underground. Small twinned lines are usually routed in the sidewalk area. Greater diameters must be laid beneath the thoroughfare.

Today the buried plastic composite jacket pipe is the most common construction technique. Other methods include the steel-in-steel pipe and pipe laying in a concrete duct.

Aboveground lines, which include installations in the basements of buildings, in parking garages, etc. often cost less to build than buried lines and are also accessible in operation. However, aboveground lines are more expensive to maintain.

### 8.1 Plastic Jacket Pipe

There are four principle reasons for the almost exclusive use of plastic jacket pipes:

1. Lower construction costs

From the cost diagram in Figure 6.2.3-2 one can clearly see the difference in costs of the plastic jacket pipe as compared with other buried systems.

2. Lower insulation rates

Damage in district heating lines is significantly less in comparison with earlier construction techniques. The plastic jacket pipe, which has been in use for more than 20 years, promises a long service life.

3. Reduced space requirements and shorter construction time

Reduced spaced requirements are particularly important along narrow city streets and streets with numerous other lines. A short construction time is a further advantage.

4. Appearance of simplicity

The simplicity of a plastic jacket pipe unit, as it appears to an observer, is certainly a factor in deciding on its use. This apparent simplicity, however, should not lead to casual handling.

For example, the extent of stresses and strains in the line depend on the backfill and the compaction of the bedding material. A deep cover means large [compressive] loads but little [tensile] strain. A shallow cover means less [compressive] loading and greater [tensile] strain. The effect of groundwater on stresses and strains in the plastic jacket pipes must be taken into account. Greater loads occur at angular deviations and take-offs.

These and a number of other problems demand special expertise in working with plastic jacket pipe systems in order to achieve technically competent and cost-effective pipe laying.

#### 8.1.1 Description, Function, Statics

The following description covers only the main features of the system.

The plastic jacket pipe consists of a steel medium pipe and a jacket pipe of polyethylene (PE), the two joined by a friction-type connection over an inner layer of rigid expanded polyurethane (PUR) foam. Sleeves are used to join the individual lengths of jacket pipe. The steel pipes are welded together. Figure 8.1.1-1 shows the typical pipe configuration. In the ground the plastic jacket pipe can undergo a certain displacement due to heating and cooling of the medium. But the medium pipe and jacket pipe always move as a unit as a result of their rigid connection.

Plastic jacket pipes, sleeves, fittings and valves are designed to European standards (see Section 10.3).

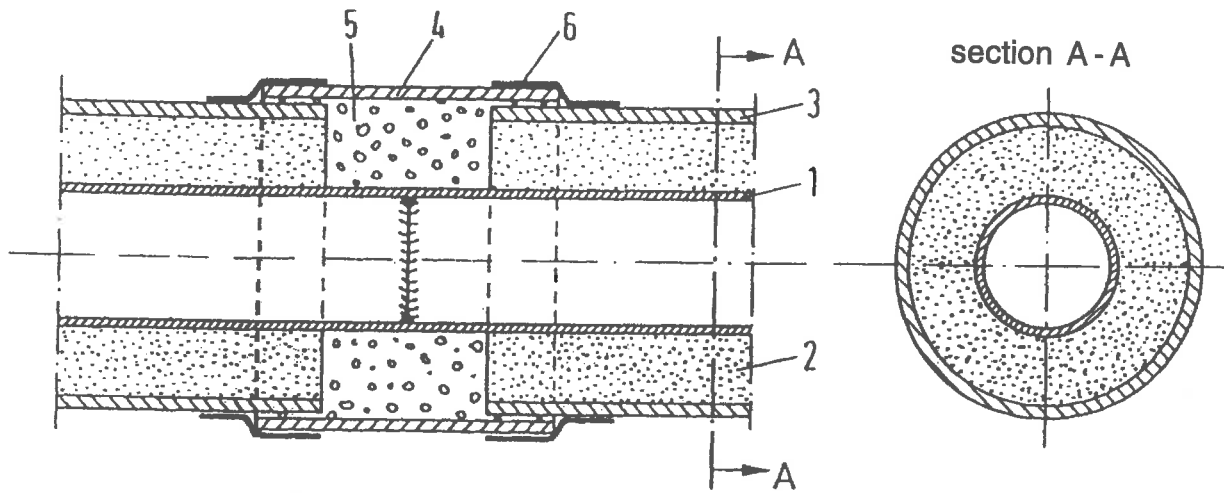

- |                            |                    |
|----------------------------|--------------------|
| 1 Steel pipe               | 4 Sleeve           |
| 2 PUR heat insulation      | 5 Site foam        |
| 3 Polyethylene jacket pipe | 6 Shrink-on collar |

In the consideration of static loads on the plastic jacket pipe a fundamental distinction must be made between loads on a straight pipe and loads on fittings. We will first consider the situation in the straight pipe.

In the case of a buried pipe, change in length in the composite pipe is complicated by the fact that each axial movement produces substantial frictional forces between the jacket pipe and the soil. Taking an exposed pipe end as starting point, these friction forces accumulate with pipe length. They reduce the freedom of movement the pipe would otherwise have and can become so great in long runs that movement on a portion of the line is completely suppressed. This motionless pipeline section is referred to as the stick zone and forms a so-called natural anchor point (NAP). Figure 8.1.1-2 illustrates this process as a function of a rise in temperature  $\Delta T$ .



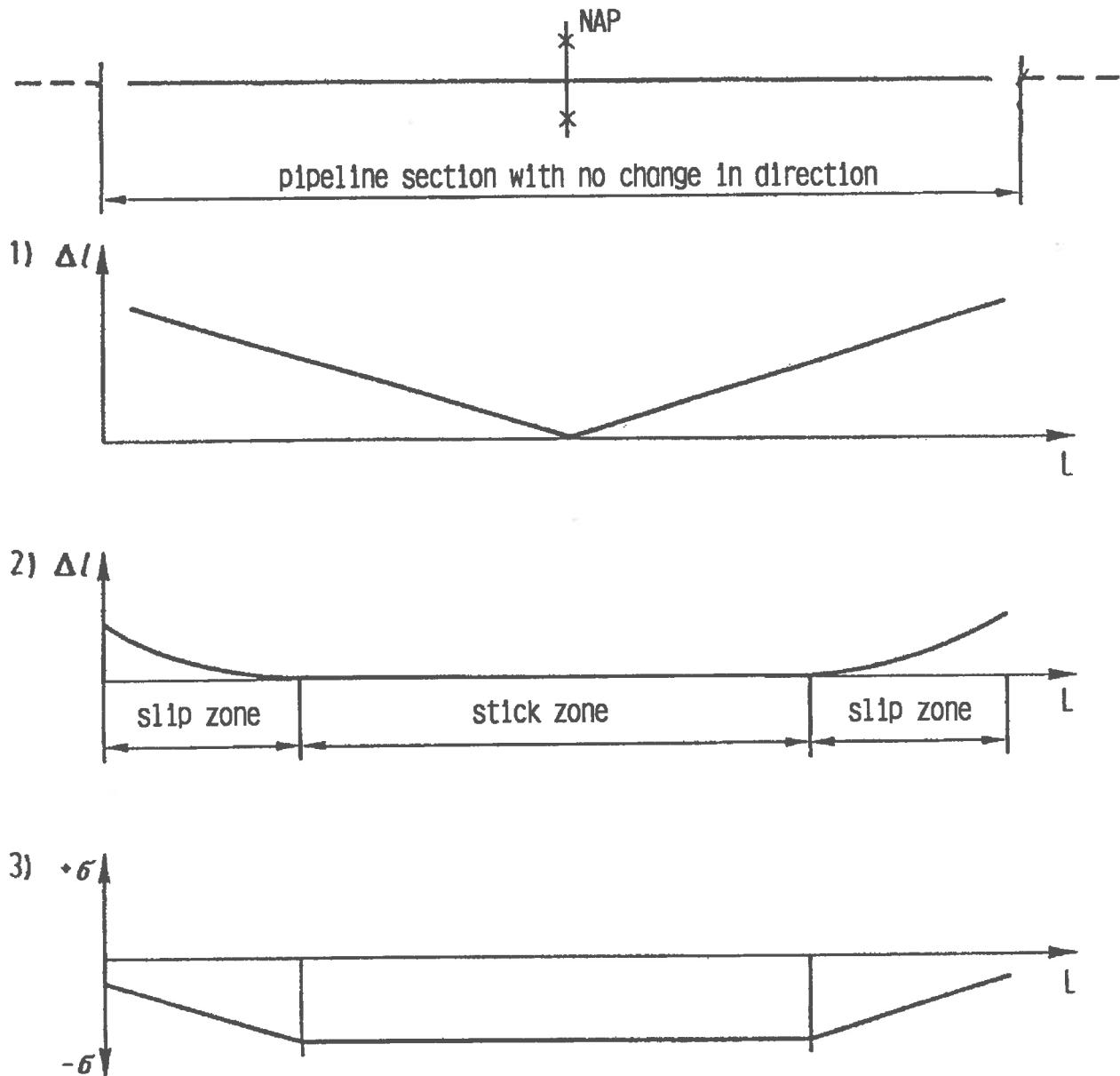

Figure 8.1.1-2 Length change and stress in response to a given temperature rise  $\Delta T$

Notes to Figure 8.1.1-2:

1. Change in length of composite pipe with all degrees of freedom, that is, with frictionless bedding;
2. Change in length when buried;
3. Axial compressive strain in steel pipe due to friction between jacket pipe and soil.

Diagram no. 1 illustrates the change in length  $\Delta L$  over a length of line  $L$  as a result of temperature-induced movement of the pipeline for the theoretical case where there is no restriction of movement due to ground friction. Due to the absence of frictional force full theoretical elongation results; there are no axial loads in the steel pipe.

Diagram no. 2 shows the movement of a buried composite pipe for the same line length. Frictional forces arise in the slip zone, the zone in which pipe movement occurs, and these forces accumulate with increasing pipe length (see Figure 8.1.1-2). At pipe length  $G$  they reach a value equal to that of the force producing movement in the steel pipe. From this point on no more pipe movement is possible since the forces producing movement and the forces hindering movement are in equilibrium.

Compressive stresses arise in the steel pipe as a result of the restricted movement. In each individual case the steel of the medium pipe must be tested for its ability to withstand the loads. In a conservative static design an allowable straight length of laid pipe is calculated from the nominal diameter, cover depth and operating temperature at which the frictional force produces a load equal to the rated value of the pipe material in accordance with ISO 9329-1 or ISO 9330-1. A compensation element must be provided for at least by the time this line length is reached (see Figure 8.1.1-3).

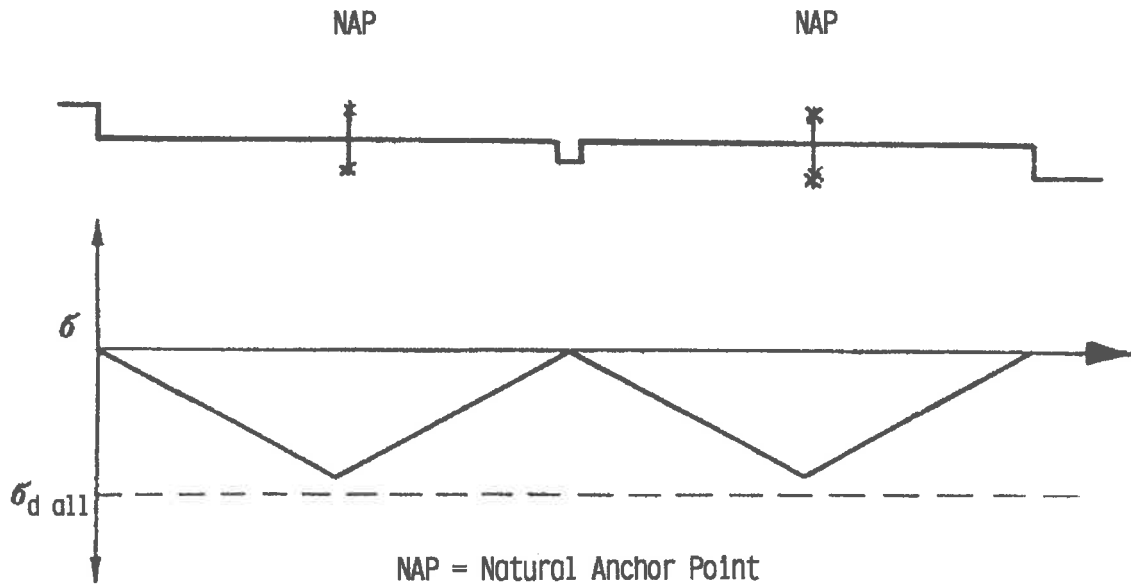

Figure 8.1.1-3.Reduction of compressive loads by limiting line length, such as between compensators.

Another possibility for reducing the loads produced and, thus, exceeding the allowable laying length lies in preheating the composite pipe. In this method the line is preheated in an open ditch and then buried once the desired temperature has been reached. In this way the stress-free state is shifted to another operating state and the compressive stress at maximum allowable operating temperature lessened. As a result a cold line produces tensile stresses instead of the stress-free state that would prevail in the absence of preheating (see Figure 8.1.1-4).

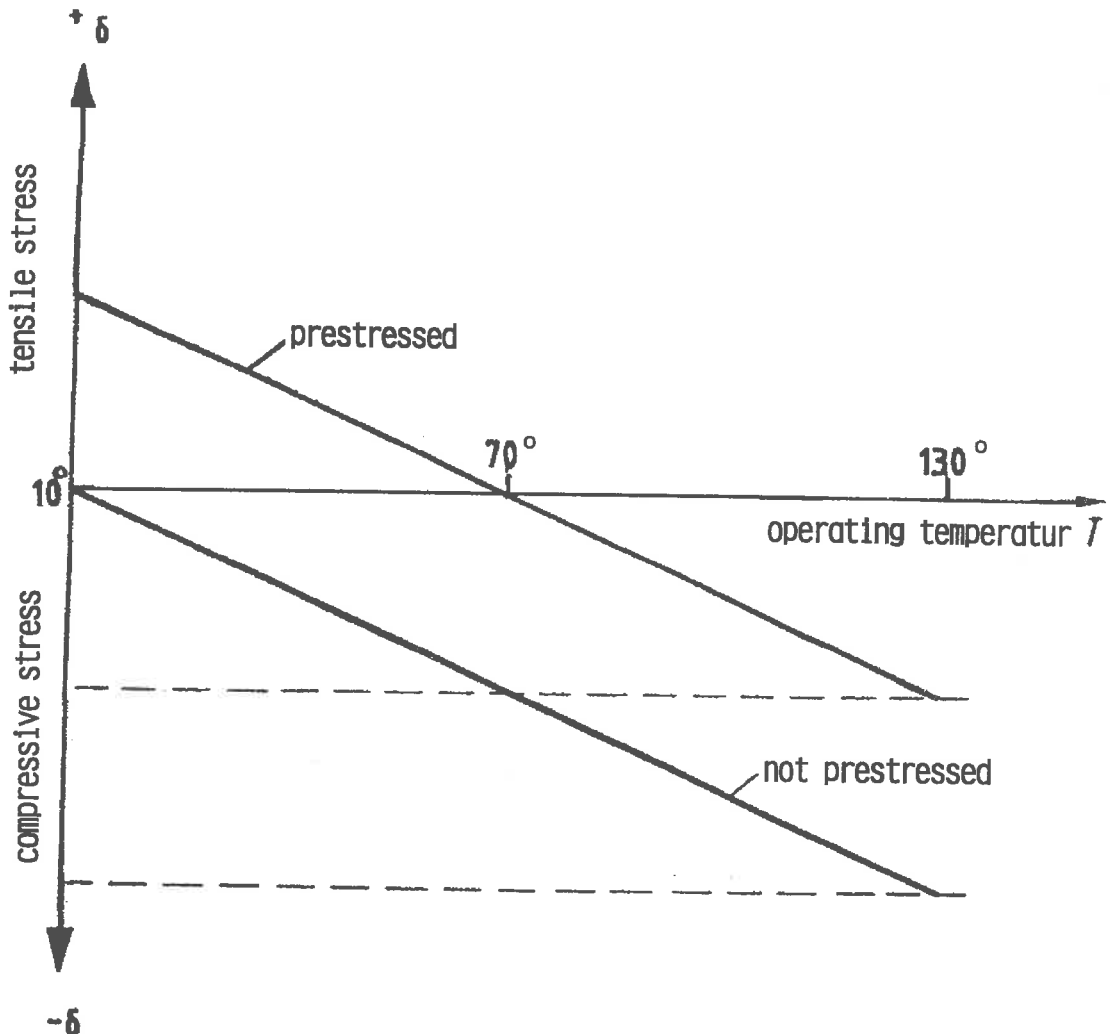

Figure 8.1.1-4 Example of axial stress in the sticking zone as a function of medium temperature.

The preheat temperature is a function of the maximum demand operating temperature, the potential for energy provision and the preheating technique employed. The preheat temperature is frequently  $\sim 70^\circ\text{C}$ , corresponding to a maximum operating temperature of  $\sim 130^\circ\text{C}$ . Lines can be preheated a section at a time, as required by local conditions. In this case, the stresses produced at section boundaries require careful attention.

To avoid exceeding the allowable axial load of 190 MPa in a straight pipe, lines with a length greater than the allowable laying length which are laid without preheating should not be used at operating temperatures greater than  $90^\circ\text{C}$ . If the maximum of  $90^\circ\text{C}$  is not exceeded, straight lines can be laid to any length without preheating and without exceeding the allowable straight-pipe axial load of 190 MPa.

New development efforts are aimed at permitting expansion in excess of 0.2% for loads on bends, tees, and so forth. This seems possible since there are few full-amplitude expansions over the life of a district heating line and the majority of stresses are caused by secondary loads. This means that instead of designing to reduce the high stress amplitudes to the thermal yield limit, a fatigue analysis is undertaken for the totality of live loads. This is required also by the fact that improved methods of calculating bedding forces in the ground produce much higher stresses than the previously simplified calculation methods [25].

Another development approach - so-called cold laying - attempts to exceed permissible straight-pipe axial loads in order to dispense with preheating. The line prestresses itself the first time it warms up once the limit of elasticity is exceeded.

### 8.1.2 Range of Application

The permissible sustained temperature for plastic jacket types with the conventional CFC blown foams used up to now has been restricted to 130°C. Moreover, manufacturers extend the warranty up to 140°C so long as the duration of sustained temperatures over the course of a year is not exceeded.

~ 135°C	£ 500 hours
~ 140°C	£ 400 hours

These values are also valid for the so-called soft or flexible foams (H-FC- and H-CFC) and the CFC-free foams.

Plastic jacket pipes should be laid with a cover of at least 0.5 m. Smaller values require an appropriate indication of ring bending resistance while values higher than 1.5 m require an indication of shearing strain resistance for the PUR foam.

### 8.1.3 Connection Technique

Sleeves serve as a connecting element between two jacket pipe ends. External forces acting on the sleeves must be absorbed. This is true also for forces applied to the sleeve edges due to soil resistance in the slip zone. Shifting of the sleeves and their seal on the jacket pipe must be prevented under all line operating conditions.

The sleeve must have reliable watertightness. The seal must be unaffected by thermal effects due to the temperature of the medium and simultaneous external and internal mechanical effects.

Because of the frequently inconvenient construction site conditions, work on sleeve connections must be performed with particular care and appropriate supervision. Improper installation can impair the quality of the connection and threaten the operational safety of the entire system.

There are basically two types of sleeves: the shrunk-on type, where the gap between the jacket and sleeve is sealed by a shrunk-on collar, and the welded sleeve type. Various welding techniques are employed for the latter. All work on sleeve connections must be performed by specially trained personnel. Manufacturer's instructions must be on hand and closely followed.

When shrunk-on sleeves are used care must be taken that the sleeve and jacket pipe are clean and dry. This is also true for pre-installed slip-on couplings and shrinkdown tubing. For welded sleeves the work must be done on site with particular care or the life span of the connection will be jeopardized. Particular measures must be taken to guard against weather effects. (The key requirements for materials, welding methods, welding personnel and product quality are covered by a German guideline (see Section 10.3 - DVS 2207, Part 5).

The PUR foam in piping elements must be dry. Wet PUR foam must be removed from piping during construction. If large areas of foam become wet, entire pipe units must be replaced. In addition, the factory-installed PUR heat insulation on pipe ends must be shortened by ~ 20 mm to permit a better contact between site foam and the piping foam material. The PUR foam components required for sleeve site foam have a limited storage life. The expiration date must be visible on their containers. Containers that are past their expiration date must not be used. The manufacturer's recommendations regarding working temperature and humidity limits for the PUR foams must also be heeded, and the work interrupted or halted if necessary. Only small quantities of PUR foam should be allowed to protrude from gaps between sleeve and jacket pipe during filling of the sleeve space. Foam ingredients must be mixed carefully. Accident prevention regulations, especially when working with liquid foam components, must be observed.

If shrinkdown tubing is applied at both ends of the sleeve and at the filling orifice, care must be taken to ensure an adequate temperature and uniform temperature distribution. The temperature required for shrink-heating should be indicated, if possible, by a colour change.

#### 8.1.4 System Monitoring and Leak Location

The early detection and rapid location of leakage points is important in pipeline systems. Plastic jacket pipes are to a large degree resistant to water diffusion. Even small quantities of moisture in the heat insulation space, such as that left over from the construction phase, will not be able to escape once the line is in operation. Even the smallest leaks, especially in the medium pipe, must be promptly detected and eliminated since they could wet longer line sections over time.

Pipeline monitoring and leak detection systems are available that can detect moisture in plastic jacket pipes. The required tracing or control wires are embedded in the heat insulation foam during fabrication of these pipe systems.

When the initial purchase of monitoring systems is contemplated it should be kept in mind that changing from one monitoring system to another is currently very difficult. The purchaser should avail himself of presentations and references to be certain that a monitoring system is reliable. The particular characteristics of such systems should be considered with a view to later expansion plans when the district heating system is first being planned.

### 8.1.5 Special Types of Plastic Jacket Pipe Systems

In addition to the standard pipe, two other pipe laying methods are employed:

1. Aquawarm  
For maximum operating temperatures to 130° C  
Range of nominal diameters: DN 10 - DN 100
2. Composite systems with plastic medium pipes  
For maximum operating temperatures to 90° C and maximum operating pressures to 6 bar.  
Range of nominal diameters: DN 20 - DN 80

#### 8.1.5.1 Aquawarm (and comparable products)

For a description of this system, the reader is referred to the manufacturer's documentation. The basic differences between Aquawarm and plastic jacket pipes are noted below:

- ◆ Pipe structure  
Around the copper medium pipe is a heat-insulating layer of compressed glass wool which is covered by a corrugated casing of HDPE.
- ◆ The pipes are flexible, are delivered either as packages or coils and are hard soldered together.
- ◆ Up to DN 50, inclusive, the product is available either with single or double pipes (two medium pipes in a single jacket pipe).
- ◆ Change in length of Aquawarm pipes in response to operating temperatures is compensated for by laying the pipes in an undulating pattern.

- ◆ With an appropriate selection of fittings both service lines and distribution mains can be laid with minimum depth of cover. The insulation on the prefabricated fittings consists of PUR foam. The fittings serve at the same time as anchor points in the system.

#### 8.1.5.2 Jacket Pipe Systems with Plastic Medium Pipes

At maximum operating temperatures of 90°C and pressures £ 6 bar plastic medium pipes can be used in place of the steel pipes in conventional district heating lines. This can result in substantial cost savings as compared with other laying methods.

Recent developments have opened the prospect of medium pipes made of crosslinked polyethylene (XLPE) and, possibly, polybutylene (PB). The market is clearly headed in the direction of XLPE, the sales of which are many times greater than those for PB.

When a district heating system is to be extended to a new service area, the decision to use plastic medium pipes will be clear when an economic comparison (different pipe diameters in different temperature ranges, costs of an additional heat exchanger utility, costs of the different service connections, etc.) demonstrates an advantage at operating temperatures £ 90°C.

Plastic jacket pipes in principle have the problem to be not totally gas-proof. From this fact results the risk that oxygen may diffuse into the heating water and causes corrosion to the steel components of the heating system.

On the other hand water vapour can diffuse into the insulation and condense, thus leading to a loss of insulation effectiveness. Lack of long time experience made it difficult during the past, to assess the resulting problems. In the meantime positive operating experience is available with new pipe system, which enables the risk of gas diffusion to be calculated.

The structure of XLPE pipes is described briefly below. The reader can find detailed descriptions and studies in the IEA report [23], which also contains comparative data on installation costs as compared with plastic jacket pipes.

The products differ in the structure of their oxygen diffusion barrier, which is either applied as a thin extruded layer of EVAL or consists of aluminum foil glued on, with fabric tape for support.

The heat insulation consists of flexible PUR or PE foam in one or more layers. In some cases the thermal insulation consists of compressed glass wool.

Pipe connections are generally made with clamp bolts and push-on couplers.



## 8.2 Other Laying Methods

Besides plastic jacket pipe there are three other systems in use, namely

- steel-in-steel pipes,
- aboveground lines and
- concrete ducts.

These are described in a general way below. Aboveground lines can only be installed where acceptable within the city landscape. Pipe laying in concrete ducts is the method that has best stood the test of time, but is also the most expensive.

### 8.2.1 Steel-in steel pipes

The steel-in-steel pipe system employs two pipes of steel in a concentric arrangement with thermal insulation in the annular gap between the pipes. The inner pipe serves as the medium pipe and the outer provides moisture protection and strength for the line. The expansion movements of the medium pipe are absorbed inside the jacket pipe. When pipe diameters are small two or more lines may be incorporated in a single casing.

Steel-in-steel pipe offers advantages on line sections with few take-offs, and so is particularly useful for large-diameter transmission mains. Since a steel-in-steel pipe offers reliable moisture protection, this system has proven to be particularly useful when pipe is laid in groundwater. It has also become a standard system. One advantage of this system is that the annular space provides good monitoring opportunities.

On small and medium-diameter lines the steel-in-steel pipe method is normally more expensive than the plastic jacket pipe system. On large-diameter lines it may be more cost effective, depending on market conditions. The cost advantage of plastic jacket pipes in the range of diameters up to DN 200 is about 20 - 40 %, in the range DN 500 - DN 700 only 0 - 20 %. Unfavourable conditions like ground water shift cost relations in favour of steel-in-steel pipes.

The steel-in-steel pipe offers the following advantages as compared with other systems:

- ◆ closed system without joints
- ◆ small space requirement
- ◆ rapid construction time due to prefabrication
- ◆ suitability for high flow temperatures.

The advantage of the steel-in-steel pipe approach lies in the possibility of achieving perfectly tight connections between prefabricated units on site and monitoring the quality of these joints by means of appropriate equipment.

Reaction forces resulting from suppressed thermal expansion may be absorbed directly by the jacket pipe, necessitating the use of concrete abutments. Figure 8.2.1-1 illustrates the structure of the system based on a bearing and an anchor point.

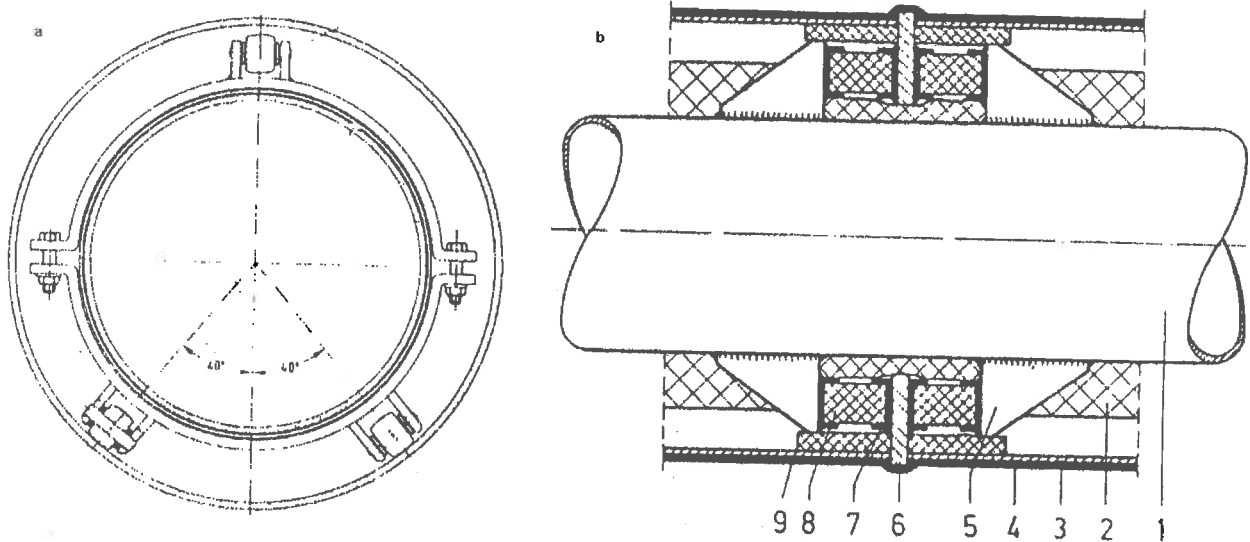

Figure 8.2.1-1: Cross section through steel-in-steel pipeline

a) Axial roller-type bearing                      b) Anchor point;  
 1 Medium pipe; 2 Heat insulation; 3 Jacket pipe; 4 Corrosion protection; 5 Metal plate; 6 Jacket pipe anchor welded in; 7 Chamber plate; 8 Heat insulation element; 9 Heat insulation.

The medium pipe is made of steel, usually St 37.0 with conventional [expansion] compensation. In systems without compensators St 52.0 is often required (see also the section on compensation). The thermal insulation consists of pressure-resistant shells. The jacket pipe is made of St 37.0 with an external corrosion protection of bituminous glass mat or polyethylene.

The bearings for the steel-in-steel pipes are predominantly star-shaped, restraint-type bearings, either sliding or roller. As noted earlier, the diverting of forces is not a problem with the steel-in-steel pipe method, and so simple sliding bearings are adequate in many cases. Roller-type supports may be preferred on longer runs depending on the system and on installation considerations.

Bearings should be designed to prevent undesirable thermal bridges arising since the outer cover of jacket pipes is only suitable for temperatures to a maximum of 50°C. For this reason a material with low thermal conductivity, such as aramid fiber-based tape, should be packed between the medium pipe and the bearing strap.

Anchor points transmit to the jacket pipe the forces resulting from restrained thermal expansion or from compensators plus friction from the medium pipe. Anchor points should also be built to prevent excessive heat flow from the medium pipe to the jacket pipe. For this reason, pressure resistant blanket insulation should be installed between the medium pipe and steel plates welded on the jacket pipe.

Sufficiently large vent openings must be provided on anchor point plates to allow evacuation of the annular gap.

## Compensation

There are two basic methods for absorbing medium pipe expansion:

1. conventional compensation with expansion units or compensators;
2. compensator-free cold stretch systems.

In the first method the medium pipe is allowed to move freely and any eventual expansion is absorbed by axial or other compensators built directly into the length of steel-in-steel pipe.

On long and straight runs the compensator-free method can be particularly cost effective.

For this purpose the medium pipe is mechanically lengthened, usually between two anchor points, to the maximum allowable limit at laying temperature and welded to the jacket pipe. This results in a compressive force being applied to the jacket pipe that corresponds to the tensile force in the medium pipe.

Where this method is used St. 52.0 is usually the preferred material for the medium pipe. In any case, expansion at line section ends (tie-ins to shafts or buildings) arising from the movement of the jacket pipe should be considered and precautions taken to offset it.

### **Passive Corrosion Protection**

Polyethylene and bituminous glass mat have already been mentioned as suitable materials for protection against external corrosion.

Specifications for polyethylene jacketing material and appropriate thickness layer can be found in DIN 30670. A somewhat greater minimum layer thickness is recommended for the jacket pipe. The maximum permissible operating temperature for the jacketing is 50°C.

Bituminous jacketing material is covered by DIN 30673. It consists of a primer and wrap layer around a glass mat of ~ 4 mm thickness for the basic variant and ~ 5-6 mm for the thicker variant. The bituminous material is recommended for elevated temperatures (tropical quality, type E6). Over-the-ditch insulation of weld joints and piping segments not preinsulated, such as elbows, requires particular care inasmuch as it must be done on site. Anticorrosion bandages and shrinkdown tubing for over-the-ditch insulation are covered by DIN 30672. It is recommended, prior to backfilling, that the jacketing be examined for holidays using an insulation-test device with a test voltage of 20-25 kV.

### **Cathodic corrosion protection (active corrosion protection)**

Successful use of cathodic corrosion protection demands special expertise.

### **Evacuation**

A vacuum must be created in the annular gap between the jacket pipe and medium pipe. Evacuation draws moisture out of the heat insulation and so not only prevents internal corrosion but also boosts the insulating efficiency by 20-25%. This is independent of whether the evacuation is ongoing or one-time.

Depending on cost, the leak-tightness of a line section can be monitored by appropriate vacuum monitoring devices and leaks recorded and located.

In creating a vacuum, structural solutions are required to isolate individual lengths of line and to maintain the vacuum-tightness of the space between the medium and jacket pipe at connections to shafts and buildings.

### **Laying technique**

Several steel-in-steel pipe units (length of units about 12 m) are placed to the right and left in a prepared trench.

Jacket pipe ends are joined by careful fitting or by means of fitted half-shells, taking care to prevent hollow welds, and the longitudinal seams must be made the load-bearing seams.

When jacket pipes are being welded the thermal insulation must be protected by zinc-coated sheet metal or fire-resistant glass fiber mats.

The pipes are laid on a bed of sand and completely covered in sand. Both the sand bed and haunching must be compacted.

The medium and jacket pipes of each line section must be welded between anchor points prior to prestressing or cold stretching.

### **Crossing of thoroughfares**

Besides the complete systems, short sections may require special measures to install casings as dictated by local conditions. Usually, to obstruct traffic as little as possible when crossing main roads, expressways and railway lines, one or two casings are installed first and the surface restored. The district heating line is then inserted.

The casing is made of steel or concrete depending on the placement method (laying, boring or thrusting) and size (accessible or inaccessible). As for corrosion protection, the same applies as for the jacket pipe in the assembly-unit method. The annular gap between the casing and line is ventilated, such as by way of adjoining shafts. For the jacketing of steel pipes polyethylene is preferred because of its dimensional stability. For cathodic corrosion protection galvanic anodes are suitable on these short line lengths.

#### **8.2.2 Aboveground lines**

Aboveground and overhead lines may be installed not only in open areas but also in the basements of residential buildings, parking garages and other buildings along the street. This method saves on excavation costs and so can more than compensate for the extra expense of such lines, such as fitting in to available space, increased thermal insulation, etc. Installation of aboveground lines is usually easiest on industrial property; on city thoroughfares close cooperation is required with architects and city planners.

Running lines through basements requires the agreement of property owners. There are examples of housing developments where more than one third of the required line length was installed in the basement of buildings. Basement laying is only possible for smaller lines, and additional thermal insulation is sometimes required.

Lines in open air are either set on concrete pedestals, steel platforms and concrete or steel stanchions or may be suspended. The distance between support elements is based on the allowable span. This can be increased by longitudinal bars atop supports. A special construction involves supports with a pivot on a foundation, so-called pendulum supports. For esthetic reasons their movement capability is little used.

In the case of exposed lines on bridges or in buildings the transmission of forces by pipe restraints must be taken into account. The capacity of the building or bridge to absorb forces is often quite limited, so that efforts are made to reduce the line's frictional forces by means of special hangings or by incorporating roller-type supports or employing low-friction materials on bearing surfaces.

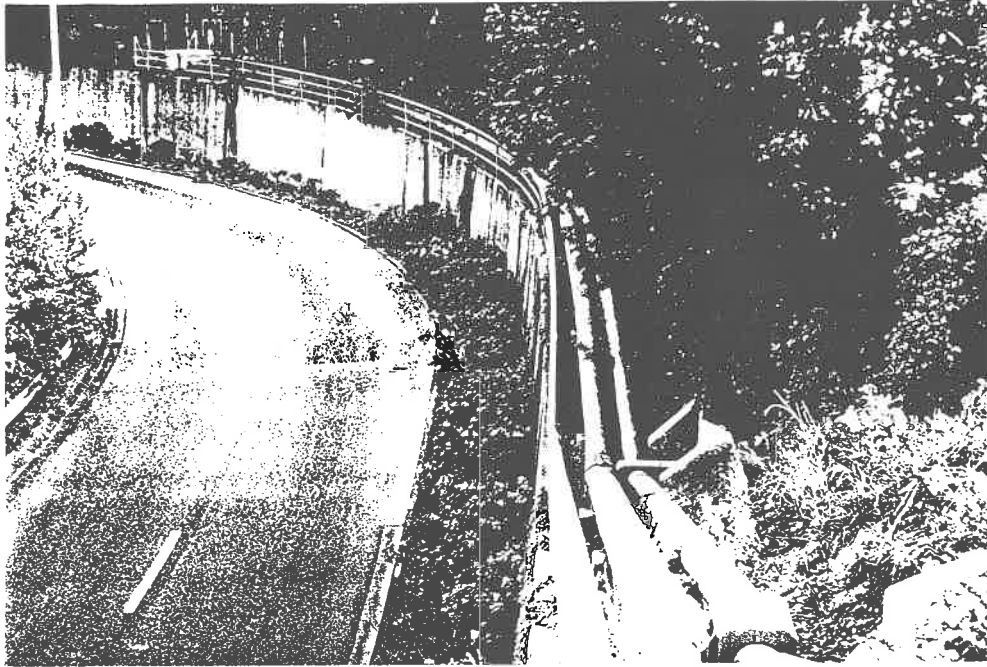

Figure 8.2.1-1: Aboveground line on a supporting wall

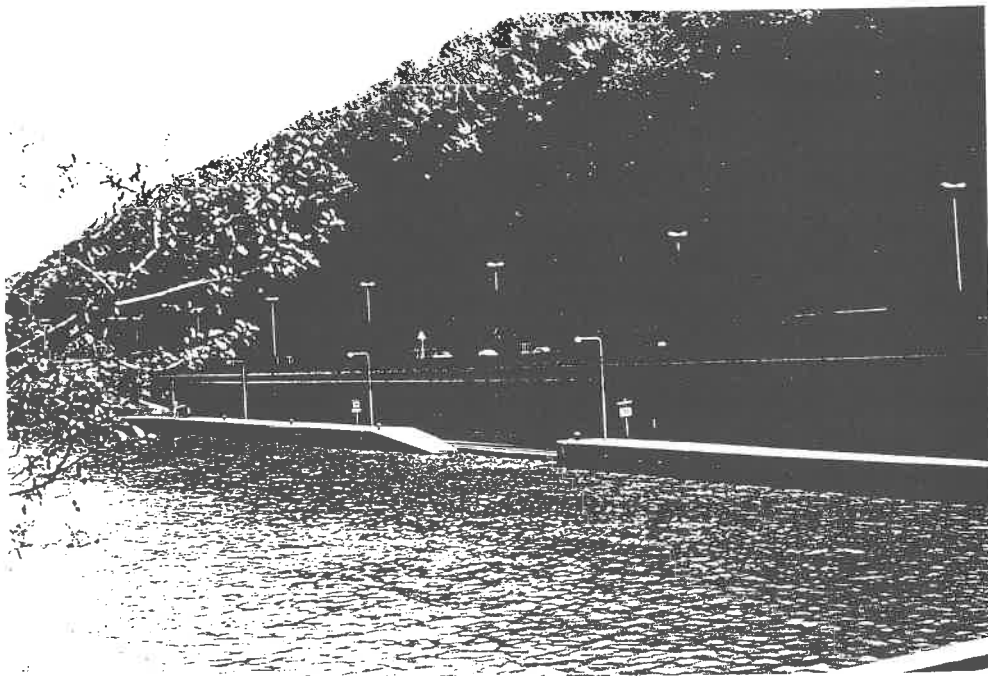

Figure 8.2.2-2: Aboveground line on a shore road.

### 8.2.3 Ducts

Concrete ducts fulfill the mechanical and moisture protection functions of steel pipelines. Special duct shapes and designs are employed for use in groundwater. Since it is normal to take precautions against surface water or moisture, ducts are usually designed with a gradient of 1-3 mm/m between shafts.

Ducts are built of ready-mixed concrete, site concrete or a combination of the two. The most common design is a duct with a rectangular cover on a base of site concrete (see Figure 8.2.3-1). In addition, a U-shaped duct made of site concrete is common and is especially useful for protecting against groundwater. For a long time a double U duct was used in Scandinavia and was standardized as a modular system. It included pipe bearings, branch connections, fittings, etc. (see Figure 8.2.3-1, no. 3).

For reasons of cost duct dimensions are as small as possible. In covered ducts a clearance of 3 to 6 cm is provided between pipes on the thermally insulated line and between pipes and the duct wall. In U-shaped ducts the clearance around the pipes must be ~ 6 cm to allow insulation to be installed. If thermal expansion can occur across the pipe axis, the clearance is increased accordingly. The clearance between insulation and base is ~ 10 cm to forestall the wetting of insulating material in the event of water ingress.

The site concrete base of the covered duct is usually reinforced. Expansion joints are incorporated into the base at 20 to 30 meter intervals to absorb thermal expansion. The sloping base is smoothly finished to allow water runoff to the next shaft. Sectional steel, gray cast-iron plates, clinkers or the concrete base itself serve as pipe supports. They must not hinder water drainage.

Horizontal frictional forces are transmitted from the bearings to the duct base, and these forces are further transferred to the ground by friction. When greater horizontal forces are foreseen, it may also be useful to integrate anchor points into the duct base.

As an aid in installation, the base of the duct is contoured on the bearing surface on which the concrete cover rests, depending on joint configuration. In order to provide a functionally sound seal for transverse joints, the face of the duct covers has a Y or other shape. To reduce the number of transverse joints, covers of longer length are often used, although this will in turn complicate installation. Cover lengths of 0.5 to 4 m are common.



1. Duct with rectangular cover

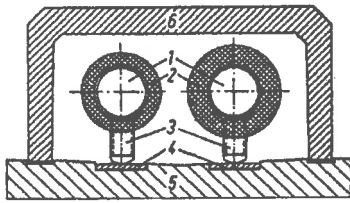

- 1 Medium pipe
- 2 Thermal insulation
- 3 Bearing

- 4 Support plates (cast iron)
- 5 Duct base (concrete)
- 6 Concrete cover

2. U-shaped duct of site concrete

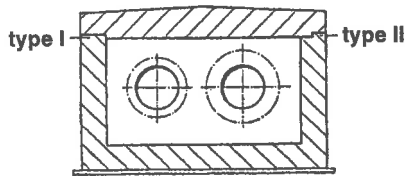

3. Scandinavian double U duct

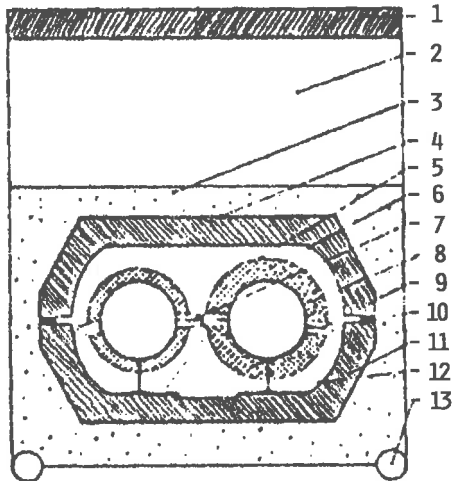

- 1 Surface
- 2 Filler gravel
- 3 Filter gravel (0-2 mm particle size)
- 4 Upper concrete inverted U
- 5 Bituminous felt jacketing
- 6 Thermal insulation
- 7 Spacer

- 8 Steel pipe
- 9 Lateral pipe guide
- 10 TOK band
- 11 Lower concrete inverted U
- 12 Sliding bearing
- 13 Drain pipe

Fig. 8.2.3-1 bis 8.2.3-3: Different shapes of ducts

### 8.3 Special Components of District Heating Lines

Expansion movements and operational characteristics of district heating lines demand special structures and components. Four important components are discussed in some detail below.

#### 8.3.1 Pipe Restraint

Pipe restraint devices must ensure faultless alignment guidance of pipes over the life of the line. This function must not be impaired by adverse operating conditions such as dirt and corrosion. In the event individual pipeline systems do not call for special pipe alignment, some time-tested solutions are dealt with below. Pipe restraints are not standardized components but are custom designed for a particular purpose. It would be helpful to have a general concept for pipe restraint for a pipeline and to standardize the bearings.

The bearings are prefabricated from standard parts. Figure 8.3.1-1 shows a design for an alignment support that can be used both as a sliding-type and without axial guidance with little modification. A support post (Figure 8.3.1-2) is often used as an anchor point on small lines. For large lines more massive structures must be used. Due to their low friction coefficient roller-type bearings are particularly useful for large lines. These are generally obtained prefabricated.

The interval between pipe supports depends on the section modulus of the pipe to be supported, the weight of water in the line, the thermal insulation, the line gradient and, in the case of aboveground lines, on snow and wind loads. Consideration must be given to permissible deflection and stresses. The support interval can also be influenced by susceptibility to vibration and the load-bearing capacity of available support points. Table 8.3.1-1 gives approximate values.

DN	Support interval [m]
25	1.7
50	2.9
100	4.4
200	7.0
300	8.7
500	11.1

Table 8.3.1.-1: Estimated values for support intervals on water-conducting district heating lines (construction material St 3.7, normal wall thickness, max. 150°C)

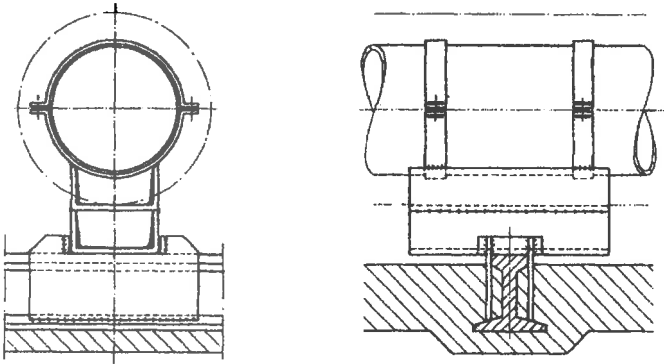

Figure 8.3.1-1: Alignment bearing consisting of standard structural shapes

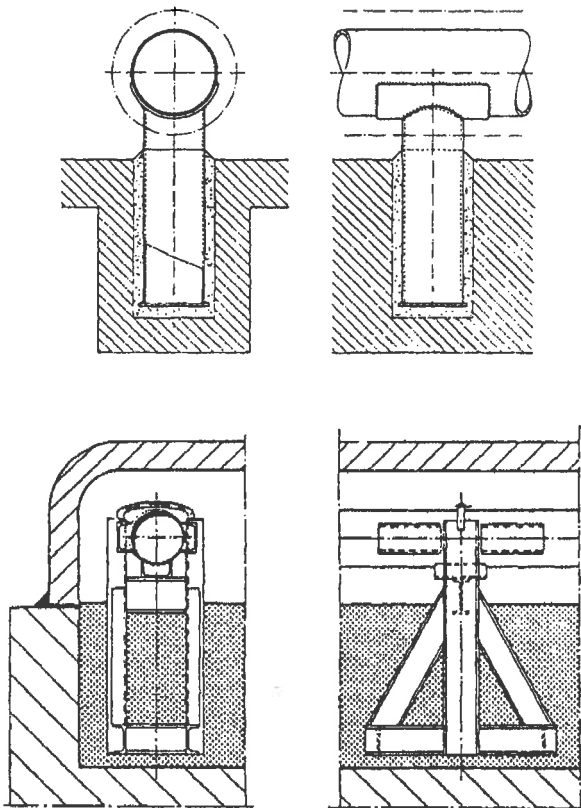

Figure 8.3.1-2: Anchor point designs.

- 1 Anchor point of tubular design
- 2 Anchor point of structural steel

### 8.3.2 Compensation

To compensate for thermal expansion L, U and Z-shaped line guides or prefabricated expansion units, compensators, are used. Natural expansion absorption as an aspect of line layout is the least expensive and is easier to implement the smaller the line. On large lines the thrust of expansion units is often so great that it cannot be accommodated by the layout. For practical convenience prestressed expansion compensators are incorporated.

Compensation should be considered as part of pipeline statics. For reliable pipe alignment, guide bearings should be provided either side of the expansion unit. The bearings must not result in unacceptable bending moments in the expansion units. U compensators must therefore be able to move freely at their crown.

Single and multiple wall corrugated pipes are used as compensators. Single-wall units, while more robust, are less elastic than the multiple wall type. The bellows consist of stainless steel and are designed for a given fatigue strength (see also AD code of practice B 13) taking into consideration the number of deformations anticipated. With axial compensators subject to inner pressure the total axial force resulting from inner pressure and bellows cross section must be diverted through the anchor points.

Articulated compensators offer good capabilities. The angular movement of the bellows combined with strain relief make it possible for them to absorb large expansions in a small space. Figure 8.3.2-1 shows some typical examples.

Other types, such as gland, flexible rubber or ball joint articulated compensators, have not proven suitable for district heating systems.

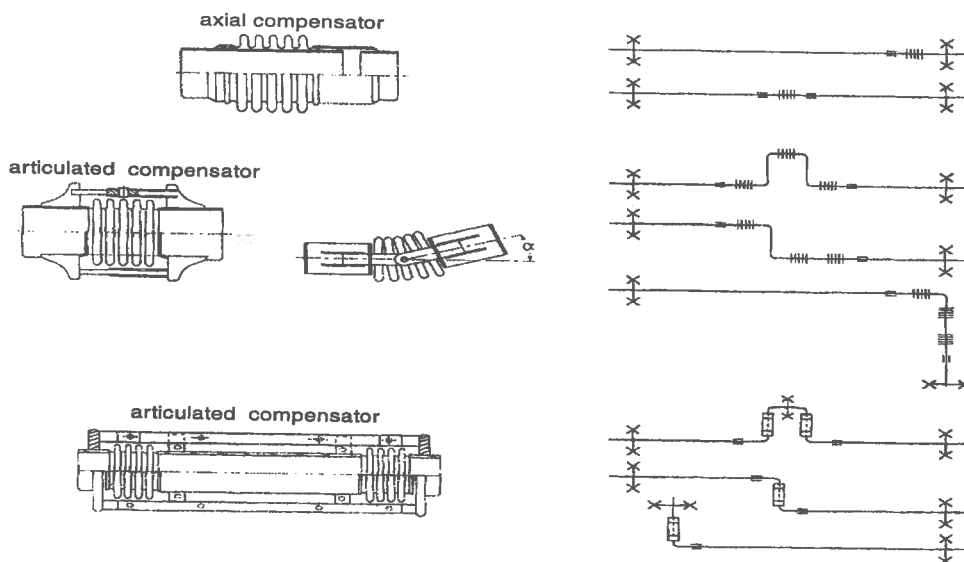

Figure 8.3.2-1 Typical exemplar for axial and articulated compensators

### 8.3.3 Valves

Valves are required to close and isolate line sections to allow new connections or repairs. They serve exclusively for shutting off flow and are rarely used for flow restriction, for which they are ill-suited due to their closure characteristics. The special demands on district heating valves derive, of course, from their use with hot water. Although the valves are only seldom called upon (perhaps once a year) they must nonetheless remain in operational readiness at all times.

In order to minimize operating costs of a district heating system with its multitude of valves, low-maintenance valves that are resistant to fouling are preferred. They should have low pressure loss and small dimensions. In the past valves were always installed in shafts or other structures so as to be accessible, but today they are built directly into the ground. Figure 8.3.3-1 shows an example of a line cut-off with venting installed under a common shaft cover of 700 mm diameter. Figure 8.3.3-2 shows a venting valve under a valve box of the type used for ventilating large pipelines.

The valves must seal on both sides. Changes in the cross section of flow in valves can cause pipe noise. The risk of noise increases with increasing flow velocity, that is, with decreasing cross section of opening.

Slide valves, globe valves, ball valves and plug valves as well as butterfly valves are used in district heating systems. Globe valves and plug and ball valves appear to be best for small lines. For very large lines the butterfly valve is often preferred to the slide valve because of its smaller size. Plug and ball valves come with plugs of three shapes - conical, cylindrical or spherical. Those with conical plugs are not used because they tend to seize; cylindrical and spherical types are used up to approximately DN 500. Butterfly valves remain convenient in size even on large lines and increasingly are being used for diameters  $\geq$  DN 200 as well. Only strong materials are used for valve housings.

Unless a valve is small, the stem can only be gear-controlled whether the valve is electrical or manually operated. This automatically produces slow response times that prevent abrupt flow interruptions. Response times are generally on the order of a few minutes. To get around overly long response times, designs call for two operating speeds, the slower speed being used, for example, closure for the last 20° of opening.

In the line the valves should not be subjected to any severe forces or moments. Since it can be advantageous, especially in plastic jacket pipelines, to transfer the forces in a pipeline through a valve housing, appropriately reinforced valves have been developed.

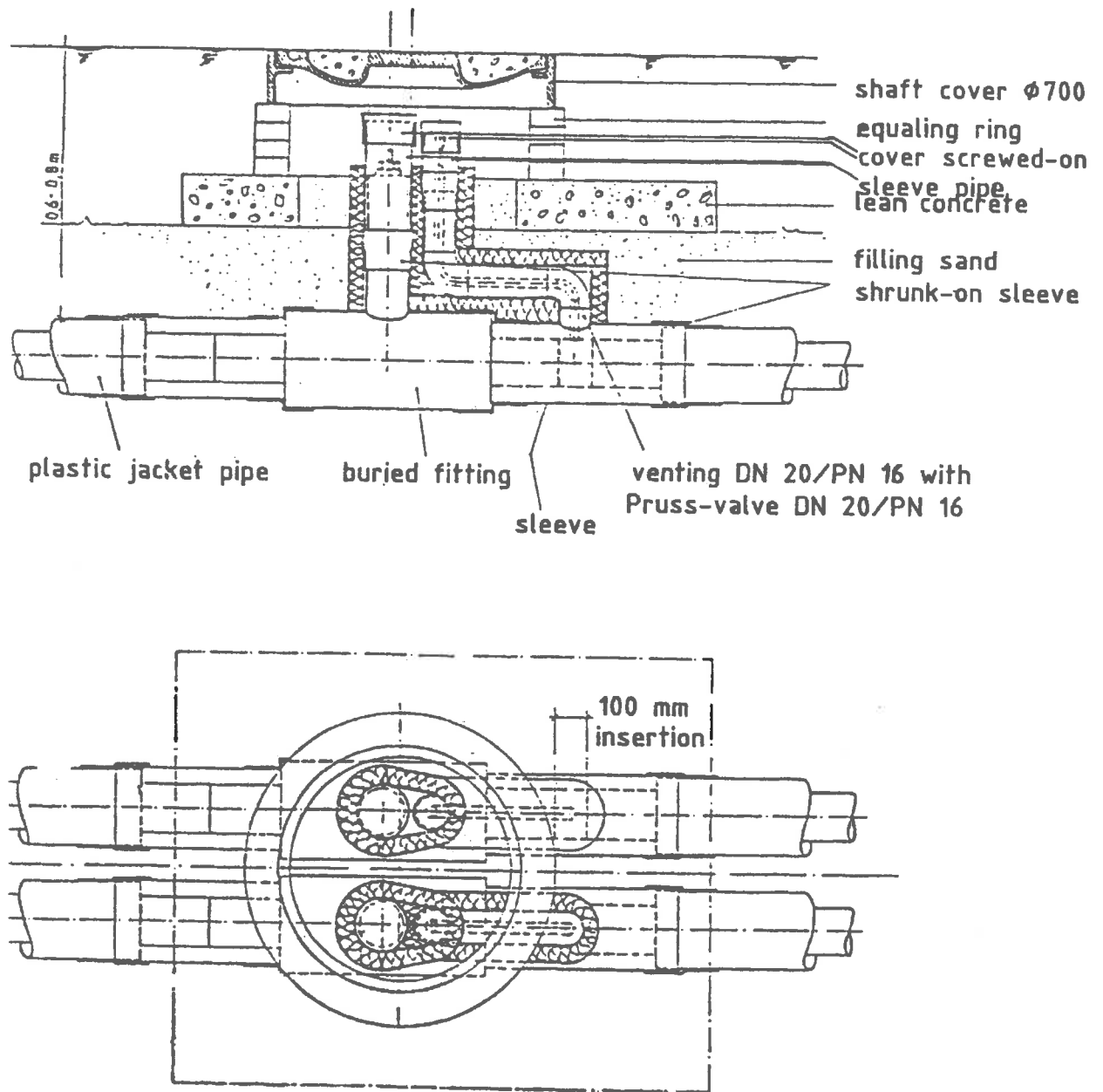

Fig. 8.3.3-1: Installation Example for Buried Fitting of DN 25 to 300 [16]

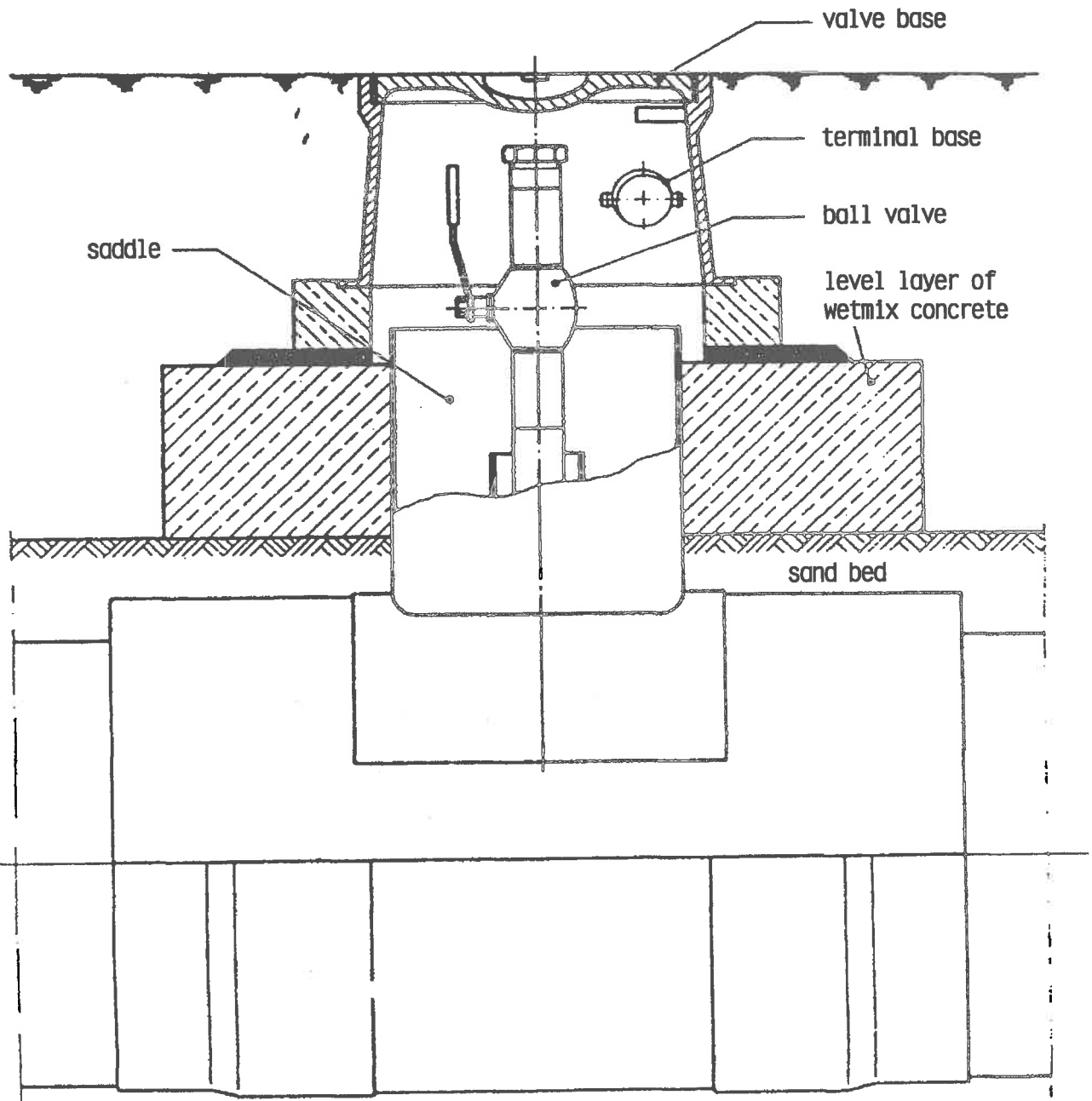

Figure 8.3.3.-2: In-ground venting valve

### 8.3.4 Shafts

On district heating lines various accessory equipment is housed in underground shafts. Because of the high construction costs, efforts are made to minimize shaft construction by installing valves directly in the ground or extending the stem to street level so that the shaft no longer needs to accommodate a person. It can also be advantageous to incorporate the shaft into anchor point construction.

District heating shafts are primarily made of site concrete or assembled from modular units. For reasons of work safety, shafts must be provided with sufficient space for access and work.

The shaft cap is usually prefabricated and can be removable or furnished with an access opening. The cap is particularly at risk from moisture since it may come into contact with condensation or surface water containing road salt. For this reason, concrete with low water permeability is used, such as water-impermeable concrete B 35 with the metal reinforcement protected by 4 cm of concrete. Another practical protective measure is to seal the cap with a plastic coating.

The shaft entrance is designed to allow ventilation while preventing the entry of surface water and obstruction of street traffic. Also for reasons of work safety the shaft is fitted with a 700 mm diameter cover and permanently installed ladders. A pump well is usually installed at the bottom beneath the entrance.

Figure 8.3.4-1 shows an example for a shaft in top view and cross section view

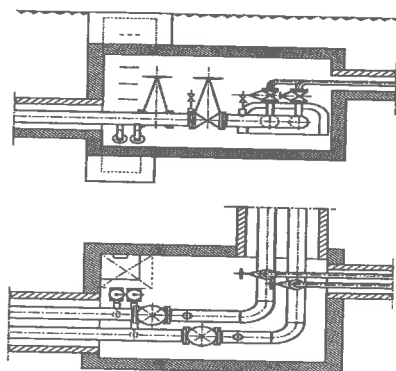

Figure 8.3.4-1: Valve shaft



### 8.3.5 Signal Cable

Modern district heating systems require electrical transmission of measurements as well as warning, malfunction and control signals for measurement and control purposes. For this purpose it is useful to install an appropriate cable line as the heating line is being built. A telephone line for internal use is also often installed. Incorporating an appropriate signal cable is more cost effective than signal transmission over public telephone lines.

Measurement and control functions in district heating systems will become increasingly important. Electronic monitoring of pipelines is virtually mandatory today, and transmission for heat metering purposes will become more common. The increasing refinement of system operations and ongoing automation by means of centralized control equipment will push up costs.

Most often, multi-wire signal transmission cables are laid simultaneously with the heating line. At the very least, however, empty conduit pipes should be placed in the trench during construction of larger lines so that suitable cables can later be inserted. An appropriate concept should be developed in due course.

## 8.4 Thermal Insulation

Heat losses in the system are unavoidable. Since the choice of insulation thickness influences the pipeline and trench cross section, thereby affecting pipeline construction costs, an optimization process is followed in determining the thickness of insulation, as described in Section 7.4. Fibrous materials have found wide application as insulation in ducts, aboveground lines and steel-in-steel pipes. Because of its low thermal conductivity, PUR high-density foam is installed in plastic jacket pipes. Experience to date suggests this foam will have an adequate useful life.

Calculations indicate that heat losses due to ventilation of concrete ducts are small in comparison with heat lost to ground. Moreover, detailed considerations of total heat transport from heating medium to ground indicate that the ground itself provides substantial insulation, especially if water content is low and soil particles are of appropriate size.

In aboveground lines temperatures in the insulating material must not fall below dew point under any circumstances. No similar risk exists with underground lines, not even in ventilated ducts. Special measures should be taken for aboveground lines, as appropriate, where the cladding may be subject to weather-related strong temperature changes. Leaving an air gap of about 15 mm beneath the cladding for ventilation and openings on the cladding underside have proven useful in this regard.

Pipe restraints have a considerable influence on heat losses in a line. Since it is not possible to easily model heat losses from general parameters, a decision must be made in each case whether special calculations for this purpose should be undertaken.

Special physical calculations of heat losses have been undertaken for numerous configurations and components. Each individual case can be calculated to the desired precision as required, but such calculations, such as with finite element methods, can be laborious.

## **8.5 Tests, Commissioning**

During pipeline construction it is normal for 10% of weld joints to be inspected, and up to 100% on critical sections.

In addition, leak and strength tests are also usually performed. Leak testing usually involves air under inner pressure or vacuum using a vacuum gauge. Strength testing is done with water at at least 1.3 times maximum operating pressure, or at least nominal pressure. Caution should be exercised with water pressure testing if there is a risk of freezing or if the line is exposed to strong sunlight.

Once laid the pipeline should be flushed prior to commissioning. The flush water is then drained off and the line filled gradually, by sections, depending on the capacity of the available water supply, in such a way as to allow entrained air to escape.

The stratification of warm and cold water that can occur during the startup process should be avoided by a sufficiently large water flow.

As in the case of safety testing, the line should be tested if possible under maximum pressure and temperature before approval for operation is given. The acceptance test procedure is recorded, the necessary improvements noted, and the latter are carried out in accordance with an agreed schedule.

## **9. Typical sequence for implementing construction work associated with a district heating project**

For reasons of efficiency, a largely standardized sequence of procedures has evolved for planning and implementing the construction work needed in connection with district heat delivery facilities. All that is needed is to fine tune the details of the standardized procedure in order to match it to a specific construction project. A procedure of this type is described in [45] and will be briefly summarized here.

Naturally, each country has its own regulations governing compliance technical standards and legal specifications, and these must be applied either instead of or in conjunction with those which are listed below.

### **9.1 Planning**

In all cases the latest cadastral plans or the official site plans should be taken as the basis for drawing up the pipe-laying or routing plans. The plans showing the layout of the district heating pipes must indicate the existing utilities and sewage facilities as well as any structures, such as sewer access or cable access shafts, which could affect the route of the district heating line. Obstacles of this kind must be taken from the relevant plans of the authorities responsible for administering the other lines. Sometimes, these basic planning data are collected together in graphic form on computer diskettes and can then be further processed in this form using CAD techniques.

The complete set of implementation drawings, such as routing, construction and assembly plans, drawings of shafts, detailed and workshop drawings, must contain all the data and facts required to permit proper completion of the work by the respective trades. The drawings and plans must be available before construction starts. The same applies to the static calculations.

### **9.2 Permits and approvals**

In the Federal Republic of Germany, utility lines, and thus also district heating lines, do not fall within the scope of the respective provincial (Land) construction code. There is no obligation to notify the authorities or apply to them for a construction permit.

Nevertheless, in some cases, the construction of a district heating line, for example, an above-ground line, may require a permit. In such cases, the need for a permit is based on other legal regulations such as those that apply to federal autobahns, major federal or provincial highways and rural roads.

It is necessary to approach the relevant agencies and offices in good time to enquire whether a permit is required or whether notification must be given of the project.

The use of public roads and property by district heating lines is usually regulated by concession agreements concluded between the municipal administrations and the operators of the district heating system. Where the owners of private property are concerned, agreements should be reached in good time on the laying of the lines, and for trunk lines appropriate easements should be recorded in the Land Registers. Agreements of this kind should be reached even if the lines have already been legally entered into development plans; the reason being that, in such cases, the use of expropriation to enforce the easements under the Federal Construction Act is only feasible if the district heating company has first made serious efforts to reach a contractual settlement with the owner of the property to grant the easement and has tried to pay compensation to the owner.

The AVB-FernwärmeV [General Terms and Conditions of Supply - District Heating Regulations] state that, as a general rule, the property of the customer receiving the district heating service can be used free of charge for laying the connecting lines and possibly also for installing a trunk line running through the property, including all necessary accessories in both cases.

### **9.3 Preparing the contract award**

Bid sets are prepared in order to invite specialist firms to submit their bids for the construction of the line. The work is usually divided up into trades such as below-grade construction, pipe construction and thermal insulation, and depending on the size of the project the contract may be awarded in sections.

The supplies and services should be described clearly and so completely, stating also the purpose of the finished line, that all the bidders understand the description in one and the same way and are able to calculate their prices reliably and without extensive preparatory work. The contractor must bear the operational risks which he can be reasonably expected to assume. For circumstances or events over which he has no control, and also for the development of prices during the term of the contract, separate agreements should be reached which distribute the risk equally between contractor and purchaser.

The performances will be described in a 'statement of specifications'. In order to permit proper pricing, and to make it easier to compare the bids, the performance should be broken down in such a way that each separate item includes only performances which can be regarded as equivalent both in a technical sense and in terms of pricing. In the statement of specifications the individual prices should be broken down according to 'supply' and 'assembly'.

As a rule, the invitation to tender is subdivided as follows:

- An invitation to submit a bid, without any costs or commitment being incurred on the part of the party inviting the bid.

- General preliminary remarks
- A description of performance with bill of quantities
- General and specific contractual conditions
- Additional contractual conditions
- Additional technical regulations
- Rules Governing the Award of Public Works Contracts (VOB-Verdingungsordnung für Bauleistungen)
- Part B of DIN [German Standard] 1961  
General contractual conditions for the execution of construction work; any amendments or additions to the contractual conditions contained in Part B must be separately stipulated.
- Part C of DIN 18300-18451  
General technical regulations applicable to construction work; any amendments or additions to the contractual conditions contained in Part C must be separately stipulate, and
- Technical legislation.

If bills of quantities are prepared using an EDP-programme, a print-out is prepared or the diskettes may be given to the bidder. All other parts of the invitation to tender will be grouped together in a manual. Normally the invitation to bid and the award of contract are based on the conditions set forth in VOB Part A DIN 1960, without granting the bidder any kind of enforceable right arising therefrom.

The statement of specifications must cover all the work to be carried out. The supplies of materials to be included in the bid must be defined. Some typical items to be included when preparing the statement of specifications are listed below as a guide. The list makes no claim to be complete.

- Breaking-up and making good again the terrain and road surfaces, depending on the particular type.
- Excavation of the trenches and construction pits; the dimensions should allow for the agreed on working widths; the excavation work may, if necessary, be subdivided into various depth levels and soil classes.
- Lining of the trenches and construction pits, subdivided into horizontal and vertical lining.

- Demolition work in the area of the trench and construction pits, divided up according to the type of demolition
- Making openings for district heating pipes to pass through masonry walls and concrete, caulking around them.
- Removing soil masses displaced by the district heating lines and new structures.
- Removing all the excavated soil masses and bringing in backfill material, if the quality and compaction of the soil make this necessary
- Removing debris and demolition material
- Manufacturing, transporting and installing finished concrete parts
- Producing the ducts, trench floors, shafts, foundations, pedestals
- Grouting the sliding bearings, thrust blocks, brackets, supports
- Producing the sand bed on the floor of the trench
- Embedding the casing pipe in sand
- Relocating existing utility lines, sewers and cables which are in the way of the heating line.
- Producing, maintaining and disassembling vehicle and pedestrian bridges
- Laying out the construction site with access and departure routes
- Transporting construction materials
- Drainage.

#### **9.4 General and specific contractual conditions**

These conditions regulate the agreements which must be concluded between the purchaser and the contractor in order to implement the construction work. They supplement the Rules Governing the Award of Public Works Contracts (VOB - Verdingungsordnung für Bauleistungen) and thereby match them in detail to the specific project.

### **Execution of the construction work**

The plans for the execution of the construction project must be available in good time before the work commences. It must be clearly stated which company or enterprise is responsible for preparing this documentation. The plans must be approved by the purchaser before construction may commence. In addition, agreement must be reached on the scope of the master plans which should exist once the construction work has been completed. Any doubts (with explanations) about the manner in which the district heating system is to be installed and the sequence in which the work is to be carried out should be brought to the attention of the purchaser in good time and together with suggestions on how to amend the process.

The final acceptance and invoicing procedures, also the payment conditions, must be agreed on. In addition, the following points must be dealt with (this list contains examples only and makes no claims to be complete):

### **Project management**

The purchaser must be represented on the construction site by a responsible project manager.

### **Construction site facilities**

Storage areas and work areas, also access routes, will be built and maintained by the contractor, at his own expense, in consultation with the authorities. Any water, sewer, electricity and telephone connections that are required must be obtained by the contractor. The costs for these performances should be shown separately in the statement of specifications. Any deviations from these agreements must be clearly established by the contracting parties.

Once the construction work is completed, the construction site equipment and facilities must be disassembled, loaded onto trucks and removed; the construction area must be cleaned up and roads, pathways, ditches, park areas, etc. must be restored to their original condition.

### **Deadlines**

The deadlines for the commencement and completion of the work must be agreed on as soon as possible between the purchaser, the civil engineering and pipeline construction companies, and all other companies involved in carrying out the work. If necessary, individual deadlines for the completion of specific sections of the construction project should be shown in a work schedule.

Any events which modify the deadlines in the work schedule should be brought to the attention of the purchaser by the contractor as soon as possible after they have occurred or been detected. A penalty or compensation for default, possibly tied to the delay involved, should be agreed on for situations in which a completion deadline is exceeded.

### **Drawings and calculation documents**

All the construction work should be carried out in accordance with construction plans and individual drawings. Any modifications to the execution of the work compared with the drawings require the prior approval of the purchaser. The contractor is obliged to build the structures in a technically perfect manner. If a drawing should contain any deficiencies which would prevent the contractor from achieving this goal, he must inform the purchaser of this circumstance.

### **Surveying work**

The costs for having a publicly appointed survey engineer, the planning engineer or the construction companies themselves survey and stake out the site of the district heating line and determine the elevation reference points shall be separately recorded.

### **Fencing and scaffolding**

The design of the scaffolding and fencing needed to permit the work to be carried out smoothly and safely shall be left to the contractor to decide. He must follow the accident prevention regulations. The construction sites must be fenced off and illuminated throughout the entire construction period. Traffic signs and facilities must be set up in good time and maintained in consultation with the road traffic authorities and the police as well as the purchaser. The traffic regulations must be observed. Payment for these performances will either be made separately, or the performances will be included in the work required to set up the site facilities.

### **Working on Sundays, statutory holidays, at night, and overtime**

If it is necessary for work to be performed on Sundays, statutory holidays or at night, the contractor, acting in cooperation with the purchaser must obtain the necessary permit from the competent authorities. For night work, the contractor shall provide adequate illumination of work and traffic areas.

Overtime will be paid only if the purchaser, for special reasons, requires that overtime be worked.



### **Breaking up the road surface**

Prior to commencing the break-up operations, the condition of the road surface should be determined together with the competent authorities and the contractor.

When roads are broken up, any reusable material such as curbstones, paving setts or slabs must be put on one side, in accordance with special instructions, and should be stored separately from backfill soils and other materials so that they can be reused at a later point in time.

Before privately owned areas are broken up, an inventory of the area, possibly including a written record, plans of existing structures and photographs of the currently existing condition, should be prepared in cooperation between the owner, senior management and the local construction manager.

### **Construction of trenches and construction pits**

Before commencing any shaft excavation work, the contractor must inform himself about the soil conditions. The excavation should be carried out in compliance with authorities and any other relevant regulations, such as Work Sheet ZH 1/441. If necessary, the excavated masses of material displaced by the ducts, shafts and pipes must be removed immediately. Excavated masses of earth which can be reused as backfill should be stored in such a way that, on one side, sufficient room is left for work to be performed and for materials to be transported. The free space on one side of the excavated trenches should be at least 1 m wide. Roadways and paths on the construction site should be maintained in a clean and safe condition. Any construction debris which gets tracked onto the roads and paths should be removed. Piles of earth should be kept off the traffic area by means of planks or at least by using duckboards so that the excavated material is not tracked around. Water run-off in gutters and ditches should be maintained by installing bridging sections and pipes.

No excavated material may be stored on top of shafts leading to other supply lines, or on survey points, hydrants, etc. Trees, shrubs, parts of buildings should be protected from damage by setting up protective cladding or walls, cf. DIN 18920 and the RSBB [Guidelines for the Protection of Shrubs and Trees in the Area of Construction Sites].

Roadways, paths and gate entrances which intersect with trenches must be provided with bridges or means of crossing the trenches; such structures must be capable of withstanding the stresses imposed on them when in use and they should be fitted with an accident-proof protective railing.

If gas and water lines, electricity and telephone cables, cable ducts, sewers, etc. are exposed during excavation, the relevant authorities should be informed and their instructions should be followed. When excavating the trenches, care should be taken not to damage any other pipes and lines along the route followed by the district heating pipes.

The other lines should be carefully protected in accordance with the instructions given. Before the trenches are refilled, any exposed pipes and lines may have to be inspected by the enterprise or authority responsible for them.

Railway/streetcar tracks must be secured and supported in accordance with the regulations of the respective transportation enterprise throughout the entire construction period.

The width of the trench should be selected in such a way that sufficient working space is left, e.g. for sealing the points on the concrete ducts. The minimum dimensions according to DIN 4124 must be observed. The amount and location of the working space required varies according to the pipe-laying method used.

In each case, prior to starting work, the purchaser and the contractor must agree on the size of the working space required and also, in the case of an open construction trench, the slope angle so that no differences of opinion can arise when measuring quantities and invoicing. Furthermore, before commencing construction, it is useful to decide on the type of pit boards to be used and the depth to which they are to be installed.

If the construction trench has been cut too deep, the error must be corrected by using lean concrete or some other suitable material.

### **Lining of pits and trenches**

The walls of the excavated trench should be immediately and expertly lined.

Removal and relocation of the trench lining, which is necessary to permit the pipes to be installed and laid, should only be undertaken by the civil engineering company and not by the pipe-laying company. In special cases it may be advisable to brace the pipe installation site with steel frames. The civil engineering company must bear the costs of the trench support work. The company is also responsible for the stability of the bracing for the period of time that other workers are employed in the trench. These other workers may not by themselves make any changes to the bracing nor may they place any impermissible stress on the bracing. The individual bracing elements may only be gradually removed as the trench is filled up. If special trench support measures are required, for example when working in poor ground or in underpinnings, the manner in which this extra support shall be provided must be agreed on beforehand and any resulting costs should be quoted beforehand.

### **Welding pits**

In order to execute circular welds on the fixed steel pipe it is advantageous to provide a recess in the floor of the construction pit over a length of 0.5 to 2 m, and oriented parallel to the pipe axis. The working space between the lower edge of the pipe and the bottom of the trench should be about 0.6 m. The lateral space at this point between the trench wall and the respective outer pipe should also be about 0.6 m.

### **Production of the concrete structures**

The concrete used should meet the specifications of the German Committee for Steel-Reinforced Concrete DIN 1045 and should be as dense and impermeable to water as possible. The formwork should be constructed without joints and should be completely flat so that a clean and smooth concrete surface is obtained. Cap sections and other finished parts should as far as possible be produced at the concrete factory.

Proof should be provided of the quality of the concrete.

In agreement with the pipe-laying company, the sliding bearing and thrust blocks will be grouted with pourable concrete. In order to save time, setting-accelerators can be added to the concrete.

Before it is covered over by the construction firm, the duct should be given one last, thorough cleaning. It is incumbent on each contractor to clean up the construction site before handing it over to the contractor. When the duct is covered over, care should be taken to protect the pipelines and the thermal insulation.

### **Backfilling the construction trench**

In general, low-grade backfill soil should be wholly or partially removed and replaced by suitable soil material. The trenches and construction pits beneath traffic-bearing surfaces should be backfilled and sealed in accordance with the 'Work Sheet for the Backfilling of Pipe Trenches'. The space between the vertical concrete wall or the casing pipe and the wall of the trench should be carefully backfilled and tamped down.

## **9.5 Liability**

The purchaser and the contractor should contractually agree that until his work has undergone final acceptance, the contractor shall bear the risk for any damage and for any infringement of the rights of third parties as well as for any losses caused by the work and services provided under the contract.

If requested, the contractor shall show proof that he has taken out the customary insurance cover for his particular trade.

## **9.6 Warranty**

The deadline for handover of the system shall be mutually agreed on by the contracting parties before construction work commences.

The contractor shall guarantee that at the time when the risk is transferred to the purchaser, the installation which he has produced possesses the contractually assured

properties, complies with generally accepted engineering standards and does not have any defects which would cancel out or reduce the value of the installation or its suitability to be used for its customary or contractually stipulated purpose.

The warranty covers, for example, the dimensionally accurate construction of the line within the height and lateral play tolerances prescribed by the pipeline construction company, as well as the stability and durability of the structure, its impermeability to surface water and, if necessary, to groundwater, as well as the prevention of subsidence of the road surface.

The warranty shall run for 2 years, calculated from the day of final acceptance by the purchaser. Longer warranty periods can be agreed on. The purchaser and the contractor should agree that the contractor is responsible for replacing, upon request, without delay and at no cost to the purchaser, all parts which become unusable or defective or suffer more than the natural amount of wear during the period of the warranty due to defective design or the use of defective or unsuitable materials. Replaced parts shall become the property of the contractor and shall be removed by him. Any resulting costs must be borne by the contractor. At the same time, it should be clearly stipulated that the contractor shall be liable beyond the warranty period for any consequences arising from culpable failure to comply with the contractual conditions.

## **9.7 Project manager**

The project manager must carry out the duties laid down in the relevant Land [state] construction code. The purchaser will inform the supervisory authorities of the project manager's name. The project manager cannot delegate his tasks, however, he may appoint a deputy, or specialist project managers may be called in if he does not possess the necessary factual knowledge and experience to perform all the duties incumbent on him. However, he is responsible for ensuring that his activities fit in smoothly with the work of the specialist project manager.

The project manager is obliged under public law to supervise the construction project so as to ensure that it is properly completed within the agreed deadline. His supervisory activities shall be based on the generally accepted standards that apply in the construction industry, as adopted in the form of construction regulations through public proclamation by the senior construction authority. The Project manager's supervisory shall also be based on individual drawings, individual calculations and instructions given by the author of the plans or, if these are not required, on the approved construction documents.

In carrying out his duties he must ensure that safe operating conditions prevail at the construction site and that the work performed by the various individual contractors shall remain unaffected by this. He shall ensure that the accident prevention regulations are observed and has the authority to issue legally binding instructions.

The construction manager may obtain insurance coverage through an employer's liability insurance scheme only in the event of negligent infringement of the secondary obligation to safeguard traffic if claims for damages, e.g. due to improper fulfillment of his duties, are brought against him.

## 10. Literature

### 10.1 Monographs, Reports, Publications

1. AGFW (editor): Bau von Fernwärmenetzen. 5. Auflage (Construction of District Heating Systems. 5th Edition).  
Frankfurt am Main: Verlags- und Wirtschaftsgesellschaft der Elektrizitätswerke m.b.H. 1993
2. Schwaigerer, S.: Festigkeitsberechnung im Dampfkessel-, Behälter- und Rohrleitungsbau (Strength Calculation in Construction of Steam Boilers, Tanks and Pipelines).  
Berlin: Springer 1978
3. Stradtman (editor): Stahlrohrhandbuch. 11. Auflage (Steel Pipe Manual. 11th Edition).  
Essen: Vulkan Verlag 1990
4. Handbuch für den Rohrleitungsbau. 4. Auflage (Pipeline Construction Manual. 4th Edition).  
Berlin: VEB Verlag Technik 1972
5. Munser, H.: Fernwärmeversorgung (District Heating Supply).  
Leipzig: VEB Deutscher Verlag für Grundstoffindustrie 1979
6. AGFW (editor): Fernwärmeversorgung aus Heizwerken. 2. Auflage (District Heating Supply from Heating Stations. 2nd Edition).  
Frankfurt am Main: Verlags- und Wirtschaftsgesellschaft der Elektrizitätswerke m.b.H. 1981
7. Recknagel, Sprenger, Hönnmann: Taschenbuch für Heizung und Klimatechnik (Handbook of Heating and Air Conditioning)  
Munich, Vienna: R. Oldenbourg Verlag 1992
8. Reichel, A.: Verfahren zum Vergleich von Energieversorgungssystemen (Comparison Method for Energy Supply Systems).  
Vienna: Metrica Fachverlag Bartak 1984
9. Mäkelä, T.: District Heating Research in Finland.  
Helsinki: Ministry of Trade and Industry 1993
10. Hakansson, K.: Handbuch der Fernwärmepaxis. 2. Auflage (Manual of District Heating Practice. 2nd Edition).  
Essen: Vulkan Verlag 1982

11. Glück, B.: Heizwassernetze für Wohn- und Industriegebiete (Hot Water Systems for Residential and Industrial Zones).  
Berlin: VEB Verlag für Bauwesen 1985
12. Värmekulvert Handbok  
Stockholm: Svensk Byggtjänst 1986
13. Diamant, R.M.E. and D. Kut: District Heating and Cooling for Energy Conservation.  
London: The Architectural Press 1981
14. Frederiksen, S. and S. Werner: Fjärrvärme  
Sweden: Studentlitteratur Lund 1993
15. IEA Report 1989:R3  
Static Problems in the Laying of Plastic Jacket Pipes  
NOVEM- Agency, Sittard/The Netherlands  
Telefax: 0031 46 528260
16. IEA Report 1989:R4  
Fittings in Plastic Jacket Pipelines  
NOVEM-Agency, Sittard/The Netherlands
17. IEA Report 1990:R5  
Welded Sleeves Technique for Plastic Jacket Pipes  
NOVEM-Agency, Sittard/The Netherlands
18. IEA Report 1990:R6  
New Methods in Underground Engineering and  
Installing of District Heating Pipelines  
NOVEM-Agency, Sittard/The Netherlands
19. IEA Report 1990:R8  
Guidelines for Converting Building  
Heating Systems for Hot Water District Heating  
NOVEM-Agency, Sittard/The Netherlands
20. IEA Report 1990:R9  
Advanced Energy Transmission Fluids  
NOVEM-Agency, Sittard/The Netherlands
21. IEA Report 1990:R10  
Heat Meters Report of Research Activities - Annex II  
NOVEM-Agency, Sittard/The Netherlands

22. IEA Report 1992:P2  
CFC-Free Plastic Jacket Pipes for District Heating  
NOVEM-Agency, Sittard/The Netherlands
23. IEA Report 1992:P3  
District Heating Piping with Plastic Medium Pipes  
- Status of the Development and Laying Costs  
NOVEM-Agency, Sittard/The Netherlands
24. IEA Report 1992:P4  
Bends for Plastic Jacket Pipe Systems Able to Withstand High  
Transverse Loadings  
NOVEM-Agency, Sittard/The Netherlands
25. Handbuch zum Programmsystem GEFKMR  
Berechnungsprogramm zur Statik von Kunststoff-  
Mantelrohrleitungen, Version 8.0 [Manual of the GEFKMR Program System.  
Calculation Program for the Statics of Plastic Jacket Pipelines, version 8.0]  
(94.1)  
GEF-Leimen, 1994
26. Report Värmeforsk  
Spänningar, Fjärrvärmeledningar  
Del 1, 2, 3  
Stockholm, 1984
27. AGFW  
Einfluß der Temperatur- und Mengengleitung in Heizwassernetzen auf die  
Betriebskosten (Effect on Operating Costs of Temperature and Flow Slippage in  
Hot Water Systems).  
Frankfurt 1992
28. Häubi, F. and G. Pape  
Untersuchung einer zum Heizöl alternativen Energieversorgung für den Rhein-  
Neckar-Raum (Study of an Alternative to Heating Oil for Energy Supply in the  
Rhine-Neckar Region).  
Siedlungstypen: Beschreibung, Datenprofile (Settlement Types: Description,  
Data Profile).  
Arbeitspapier ur B 2.1.3/03  
Büro für Raumplanung, Umweltforschung, Städtebau und Architektur,  
UELI ROTH, Zürich, June 1981



29. Mathenia, Th.  
Erweiterungsmöglichkeiten der Fernwärmenetze bei forcierter Nutzung der Abwärme aus industriellen Anlagen, die dabei auftretenden Speicherprobleme sowie wirtschaftliche Verlegetechnik (Expansion Possibilities for District Heating Systems with Forced Waste Heat Utilization from Industrial Facilities, Associated Storage Problems and Economic Laying Methods).  
Fortschritt-Berichte der VDI-Zeitschriften Reihe 6, Nr. 150  
Düsseldorf: VDI-Verlag 1984
30. Mosler, J.  
Wärmeverlust von Fernwärmeleitungen (Heat Loss from District Heating Lines).  
Dissertation, Dortmund 1987
31. LLY Lämpöläitosyhdistys ry.  
Erleichterungsmöglichkeiten der Fernheizungssysteme in Kleinhausbereichen und kleinen Siedlungsgebieten (Simplification Possibilities for District Heating Systems in Small House and Small Residential Development Zones).  
Helsinki: 1985
32. Bericht - Bundesminister für Forschung und Technologie  
Technik des Leitungsbaus (Report of the Federal Minister for Research and Technology. Line Construction Technique).  
GEF - Ingenieurgesellschaft Leimen/Chemnitz 1993
33. Bericht - Bundesminister für Forschung und Technologie  
Wirtschaftliche Rahmenbedingungen für die Fernwärmeversorgung (Report of the Federal Minister for Research and Technology. Fundamental Economic Conditions for District Heating Supply).  
Wirtschaftsberatung WIBERA, Düsseldorf 1993
34. Bericht - Bundesminister für Forschung und Technologie  
Sanierung and Betriebsoptimierung von Wärmeverteilungsanlagen (Report of the Federal Minister for Research and Technology. Rehabilitation and Operational Optimization of Heat Distribution Systems).  
Institut UMSICHT, Oberhausen 1993
35. Bericht - Bundesminister für Forschung und Technologie  
Unternehmensstrukturen für die künftige Entwicklung einer leistungsfähigen Fernwärmewirtschaft (Report of the Federal Minister for Research and Technology. Enterprise Structures for Future Growth of an Efficient District Heating Market).  
Wirtschaftsberatung WIBERA, Düsseldorf 1993

36. Piller, W. and M. Rudolph  
Kraft - Wärme -Kopplung  
- Zur Theorie und Praxis der Kostenrechnung (Force/Heat Coupling).  
VWEW- Verlag, Frankfurt/M. 1984
37. Schaefer, H. (editor)  
Energieeinsparung und Umweltentlastung bei der Wärmeversorgung von  
Industrie und Gewerbe (Energy Savings and Environmental Relief in Supplying  
Heat to Industry and Commerce).  
TÜV-Rheinland-Verlag, Cologne 1988
38. Schimmel, R.  
Kostenuntergrenzen im Leitungsbau (Minimum Costs in Line Construction)  
Lecture, Nuremberg, 1992
39. Eisenhauer, G. and K. Ziegler  
Rohrleitungen und Zubehör für Fernwärmenetze.  
Planung, Konstruktion, Berechnung (Pipelines and Accessories for District  
Heating Systems. Planning, Construction, Calculation)  
Fernwärme International, Special edition, 1972/1973
40. Eisenhauer, G.  
Fernwärmeleitungsbau (District Heating Pipeline Construction).  
Lecture, Bielefeld, 1990
41. Groh, H. and R.W. Gutsch  
Netzplantechnik (System Planning Method).  
VDI-Verlag, Düsseldorf, 1982
42. Icking, M.  
Zur Modellierung des dynamischen Betriebes von Fernwärmesystemen (On the  
Modelling of Dynamic Operation in District Heating Systems).  
Diss[ertation], Dortmund, 1994
43. Andersson, S. and L. Mattson  
Temperature Variations in DH Systems (preliminary information).  
Lund, 1993
44. Festigkeitsberechnung von Fernwärmeleitungen (Strength Calculations for  
District Heating Lines).  
AGFW, Frankfurt/M. 1989

45. AGFW (editor)  
Bau von Fernwärmenetzen  
5. Auflage  
AGFW, Frankfurt/M. 1993

## 10.2 Periodicals

Technical studies on district heating supply can be found primarily in the following periodicals:

1. Fernwärme International, District Heating. Editors: AGFW und Unichal. Frankfurt am Main: Verlags- und Wirtschaftsgesellschaft der Elektrizitätswerke m.b.H.
2. 3R international. Vulkan Verlag, Essen
3. Stadt- und Gebäudetechnik, Berlin
4. BWK Brennstoff-Wärme-Kraft; VDI Verlag Düsseldorf
5. Energie Spektrum, Resch-Media Mail Verlag, Gräfelfing
6. HLH Heizung, Lüftung/Klima, Haustechnik - VDI Verlag Düsseldorf

## 10.3 Standards and Guidelines

- EN253 Werksmäßig gedämmte Verbundmantelrohrsysteme für erdverlegte Fernwärmenetze - Verbund-Rohrsystem bestehend aus Stahl-Medium-rohr, Polyurethan-Wärmedämmung und Außenmantel aus Polyethylen hoher Rohdichte.  
[Factory insulated composite jacket pipe systems for buried district heating systems; composite pipe system consisting of steel medium pipe, polyurethane thermal insulation and external jacket of high apparent density polyethylene]
- EN 448 Werksmäßig gedämmte Verbundmantelrohrsysteme für erdverlegte Fernwärmenetze - Verbund-Formstücke bestehend aus Stahl-Medium-rohr, Polyurethan-Wärmedämmung und Außenmantel aus Polyethylen hoher Rohdichte.  
[Factory insulated composite jacket pipe systems for buried district heating systems; composite fittings consisting of steel medium pipe, polyurethane thermal insulation and external jacket of high apparent density polyethylene]
- EN 488 Werksmäßig gedämmte Verbundmantelrohrsysteme für erdverlegte Fernwärmenetze - Vorgeämmte Absperrarmaturen für Stahl-Medium-rohr, Polyurethan-Wärmedämmung und Außenmantel aus Polyethylen hoher Rohdichte.  
[Factory insulated composite jacket pipe systems for buried district heating systems; pre-insulated shut-off valves for steel medium pipe, polyurethane thermal insulation and external jacket of high apparent density polyethylene]

- EN489 Werksmäßig gedämmte Verbundmantelrohrsysteme für erdverlegte Fernwärmenetze - Rohrverbindungen für Stahl-Mediumrohr, Polyurethan-Wärmedämmung und Außenmantel aus Polyethylen hoher Rohdichte.  
[Factory insulated composite jacket pipe systems for buried district heating systems; pipe connections for steel medium pipe, polyurethane thermal insulation and external jacket of high apparent density polyethylene]
- DVS 2207 Schweißen von thermoplastischen Kunststoffen  
Teil 5 Schweißen von PE-Mantelrohren - Rohre und Rohrleitungsteile  
[Welding of thermoplastics.  
Welding of PE jacket pipes; pipes and pipeline segments]  
Deutscher Verband für Schweißtechnik, February 1993
- DIN 4747 Fernwärmanlagen  
Part 1 Sicherheitstechnische Ausführung von Hausutilityen zum Anschluß von Heizwasser-Fernwärmenetze  
[District heating systems.  
Safety-related design of house utilitys for connection to hot-water district heating systems]  
July 1989

## 11. Acknowledgements

The writing of this manual was prompted by a suggestion from Canadian heating engineers that was enthusiastically supported by British experts. Initial discussions took place both in the IEA Expert Group "Heat Distribution" as well as in the IEA Executive Committee "District Heating and Cooling." R. Brandon, Ottawa, and P. Davidson, London, participated actively in formulating the content of the book, as did S. Andersson of Malmö.

Editorial responsibility for the book was entrusted to the firm of GEF - Ingenieurgesellschaft of Leimen, Germany. GEF is responsible for the content and accuracy of the presentation.

In order to provide a general overview and to avoid purely national characteristics, GEF has made an effort to involve foreign experts. The persons named below reviewed the draft documents prepared by GEF and added additional material and illustrations as well as textual contributions. In addition, Mr. S.T. Bakken developed the entire section on hydraulics and from Mr. Risager we have the guidelines for connection systems.

S.T. Bakken, Oslo - Norway  
 S. Frederiksen, Lund - Sweden  
 A.J. Horemann, Purmerend - The Netherlands  
 T. Nordenswan, Stockholm - Sweden  
 K. Risager, Fredericia - Denmark  
 V.-P. Sirola, Espoo - Finland

The manuscript was written in German with parts in English. The translation into English was entrusted to Rob Brandon in Canada. The text, figures and tables were also prepared there for printing.

The project received constant support from the IEA Expert Group "Heat Distribution." It helped in organizing the voluminous material, in facilitating conversations with participants in other countries and, through its many efforts, helped to advance the work from the initial idea to the printed product. The members of the expert group are:

S. Andersson, Malmö, Sweden  
 R. Brandon, Ottawa, Canada  
 R. Couch, Brecksville, USA  
 N.P. Garrod, Sheffield, Great Britain  
 M. Klöpsch, Leimen/Heidelberg, Germany  
 K. Mikalsen, Oslo, Norway  
 Ra, Zong-Ung, Seoul, Korea  
 P. Rimmen, Odense, Denmark  
 K. Risager, Kolding, Denmark  
 W. Schaefer, Jülich, Germany

V. Schroeder-Wrede, Cologne, Germany  
V.-P. Sirola, Espoo, Finland  
A. Sijben, Sittard, The Netherlands

We would like to express our gratitude to all those who contributed to the work of preparing this book.

GEF - Ingenieurgesellschaft, Leimen





# IEA District Heating and Cooling

---

## GUIDELINE TO PLANNING AND BUILDING OF DISTRICT HEATING NETWORKS

Published by  
**Netherlands Agency for Energy and the Environment**

Mailing address: P.O.Box 17, 6130 AA Sittard, the Netherlands  
Street address: Swentiboldstraat 21, Sittard  
Telephone: +31 46 4595295  
Telefax: +31 46 4528260

1996: N 3.1  
ISBN 90-72130-84-7