

International Energy Agency

IEA District Heating and Cooling

Programme of Research, Development and
Demonstration on District Heating and Cooling

EXECUTION OF CONNECTIONS TO PIPELINES IN OPERATION

Published by

Novem

Netherlands agency for energy and the environment



Acting as operating agent for
the IEA District Heating and Cooling project

1996: N 3.3

International Energy Agency

Programme of Research, Development and Demonstration on District Heating

Execution of Connections to Pipelines in Operation

Dealing with the subject:

**GEF Ingenieurgesellschaft für Energietechnik und Fernwärme mbH
Ferdinand-Porsche-Str. 4a, 69181 Leimen, Germany**

Leimen, March 31, 1995

Contents

1. Summary
2. Introduction
3. Welding to water-filled pipes
4. Representation of principle procedure techniques for the manufacturing of a pipeline connection without interruption of service
 - 4.1 The drilling-in and milling procedure
 - 4.2 The shear-off procedure (firing-off)
5. Description of drilling-in machines on the market
 - 5.1 TONISCO
 - 5.2 Hütz + Baumgarten
 - 5.3 Walther & Partner
 - 5.4 MANIBS
 - 5.5 Pan-Isovit/Flamco-T-Plus
6. Criteria to the judgement of the drilling-in machines
 - 6.1 Opportunities and limitations (temperatures, pressure, drill size)
 - 6.2 Handling of the drilling-in machines
 - 6.2.1 Space conditions while drilling-in
 - 6.2.2 Pressure test and control during drilling-in
 - 6.2.3 Drill and milling drill
 - 6.2.4 Removal of cuttings
7. Aspects of technical safety
 - 7.1 Safety of the connecting construction and the drilling-in machine
 - 7.2 Job safety at the drilling
8. Comparison of costs
 - 8.1 Investment costs
 - 8.2 Comparison of costs of drilling-in systems for the realisation of a connection
9. Acknowledgements

Appendix

- A Addresses of manufacturers
- B Minimal wall thickness for branch pipes (pipe at pipe) according AD-sheet B9
- C Example for guideline for the connection of a branch pipe by drilling-in
- D Drilling-in service of TONISCO

1. Summary

The execution of connections to pipelines in operation is a proven technology for long time in the field of gas and water and is used more and more in applications in the field of district heating. The advantages are clear:

- ◆ No more emptying the pipeline.
- ◆ Heat distribution is not interrupted.
- ◆ Construction of networks is possible without a variety of shut-off devices and inspection chambers
- ◆ Drilling-in is a fast and inexpensive technology.
- ◆ Repair of damaged pipelines possible by drilling-in without interrupting the service

Welding the drilling support at the filled-up pipeline was seen for long time as the critical point for the application of the drilling-in technique. In a detailed essay of the Technische Werke Stuttgart (TWS), in co-operation with the TÜV, welding to water-filled pipes was examined and the conclusion was that with certain requirements, e.g. the use of specific electrodes, a sufficient welding seam quality is obtained. From a welding point of view nothing opposes drilling-in.

Five manufacturers altogether are present on the market with equipment to create connections to filled pipelines without interruption.

At this time two principally different procedures are offered:

- ◆ The drilling-in and milling procedure
- ◆ The shear-off procedure (firing-off)

The drilling-in and milling procedure is offered by four manufacturers and uses a milling drill in combination with a centre drill for milling the pipe wall. The procedure requires a drain armature which is either connected directly with the drilling-in machine (a so called drain-drill-machine) or is separated from the actual drilling-in machine and connected to it. The drilling-in machines are on the market for several years partially and have proved themselves at a variety of drillings.

At the shear-off procedure the pipe wall is separated by means of a cutting club . The ripped off pipe wall is caught in the system-unit cover. The cutting club is accelerated by a priming mechanism, therefore it is called "Anschießen", firing off. The firing-off is a new development and has been on the market only for a short time.

The limitations of the drilling systems are enclosed by:

- ◆ Max. Temperature Approx. 130 ° C
- ◆ Max. Pressure Approx. 16 -- 25 bar
- ◆ Max. Drill size DN 400

Therefore all are applicable in normal district heating installations.

For firing-off an especially dimensioned piece of equipment is required for every combination of drill size and main pipeline size. The connecting dimension is limited to DN 25/32 and the main pipeline to DN 80.

A comparison of the costs points out that prices for purchasing a drilling machine with appliances differ greatly and are hard to compare while the machines do cover different dimensions. Prices vary from DM 6.000,- to DM 40.000,-.

A comparison of the costs for producing a connection has shown that the drilling-in machine of TONISCO is the most economic one and that shearing-off is the most expensive. It should be considered though that a drilling-in closure with a closing disc is used at the TONISCO system as drain armature which is very inexpensive compared to other armatures. Safety reconsiderations oppose this system since a total closeness at drilling cannot be guaranteed.

The shear-off system however is more advantageously compared to drilling-in only than if a distribution company practises only a few drillings per annum out or if narrow working space excludes the use of a drilling-in machine.

Doubts on grounds of technical safety are further argument against the drilling-in technique. Demands of trade organisations led to requirements for a construction admittance for drilling-in machines in which the equipment is checked for technical safety and a clearance certificate is emitted. Exact checking guidelines are in process but not yet formulated.

To sum up:

Drilling-in is starting to become a frequently used technology in district heating. It facilitates the production of an additional connection without interruption of service. The equipment offered on the market has partly proved it self already for years and there are dedicated machines and procedures for almost every case in district heating. Technical safety risks have to be classified low under consideration of specific requirements.

2. Introduction

The expansion of district heat supply to areas with low heat demand requires a consistent use of all possibilities to cut costs, in the pipeline construction too. One of the possibilities examined in this work is the forceful application of drilling-in techniques on pipelines in operation.

The essential use of this technology is the production of additional connections. First shall be revealed with an example that the drilling-in technique in principle offers a cost cutting potential. This allows already for a reduction of the building costs at the planning of the distribution network where at larger dimensions a variety of shut-off armatures requires considerable investments.

A reduction of the construction costs is possible because by this approach one can do without installing connection support nozzles for all potential customers along a main distribution line. Many nozzles appear to be abundant later on. Construction costs can be limited this way too because the time needed to realise connections with the drilling-in techniques is very limited. It is even possible to create open works which can be operated with simple safety measures.

Operation costs can be reduced by this drilling technique while the distribution company has no losses of revenue due to longer fall outs of operations. No costs appear for emptying and filling of additional parts of the network.

The drilling-in technique is not used as often as possible. Goal of this examination is to present and to compare in function and handling all common drilling-in techniques on the European market. Next to the description of the technology are presented the limits of use, opportunities and matters of security on the job. A comparison of costs of the available drilling-in techniques is in the conclusion.

3. Welding to water-filled pipelines

An essential prerequisite for the application of the drilling-in technique at district heating pipelines is the certain control of the technique of welding to water filled pipes. Doubts were revealed against welding a drilling-in nozzle to the water-filled pipe particularly for two reasons:

- A One is fear that the material of the filled pipe does not melt sufficiently since a large portion of the heat is drained by vaporising or by flowing water.
- B Another reckons with more hardening due to shock-wise cooling down of the welding material. Higher hardening values indicate generally lower toughness and increased vulnerability of the material for cracking.

In a paper [1], supported by the BMFT, the TWS examined the welding to water-filled pipes and worked out recommendations for such welding activities. An optimisation of the technical welding parameter was done in a variety of welding try outs under different internal operating conditions. A mechanical check of the welded components revealed information on the quality of obtainable welding seams. Furthermore strength calculations were carried out for a disclosure test case.

The most important results are:

Partial un-satisfying welding seam qualities were obtained at welding try outs with the usual welding technique under work conditions at which numerous shrinking cracks did appear.

Sufficiently good welding connections could be obtained under the following conditions:

- ◆ Adjustment of the work piece under workshop conditions
- ◆ Shape of weld and number of runs considering of the constructive conditions
- ◆ Use of KB electrodes with smaller welding-wire diameters

In illustration 3-1 the influences are represented of the entry of high heat at the water-filled pipe. Cross sections of the welding-seams show that burning depth and extension of the heat influence zone reduce in the order "empty pipe - pipe filled with hot water - pipe filled with cold water". The influence of differences in heat drain on the hardening values is for directly welded nozzles presented in illustration 3-2.

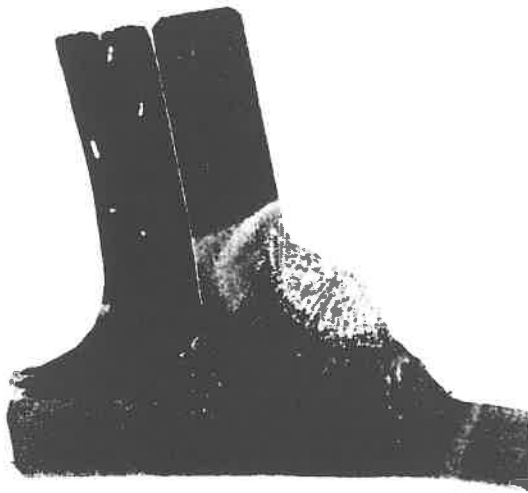

a) Welding at empty pipe



b) Welding to water-filled pipe
(approximately 105 ° C)

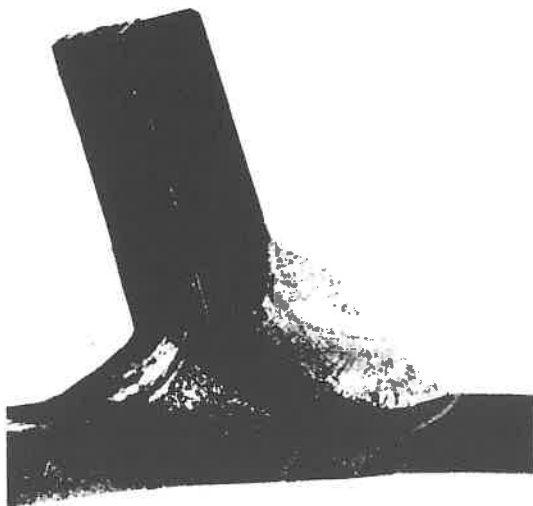

c) Welding to water-filled pipe
with pre-heated surface for
sweat-water drying

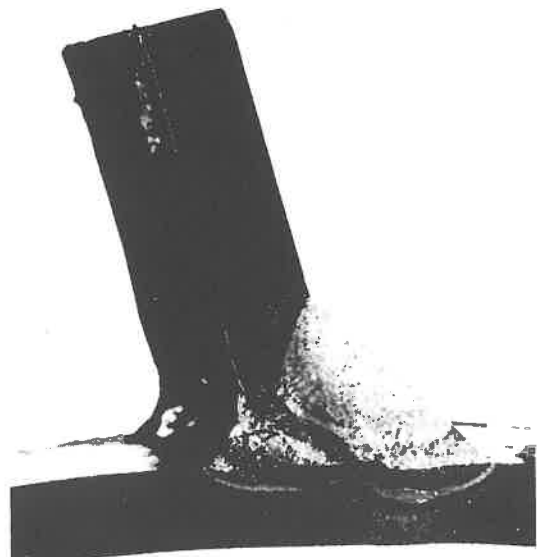

d) Welding to water-filled pipe
(approx. 16 ° C)

Illustration 3-1: Different influences of high heat drain on welding depth and extension of heat influence zones at the example of directly welded nozzles [1]

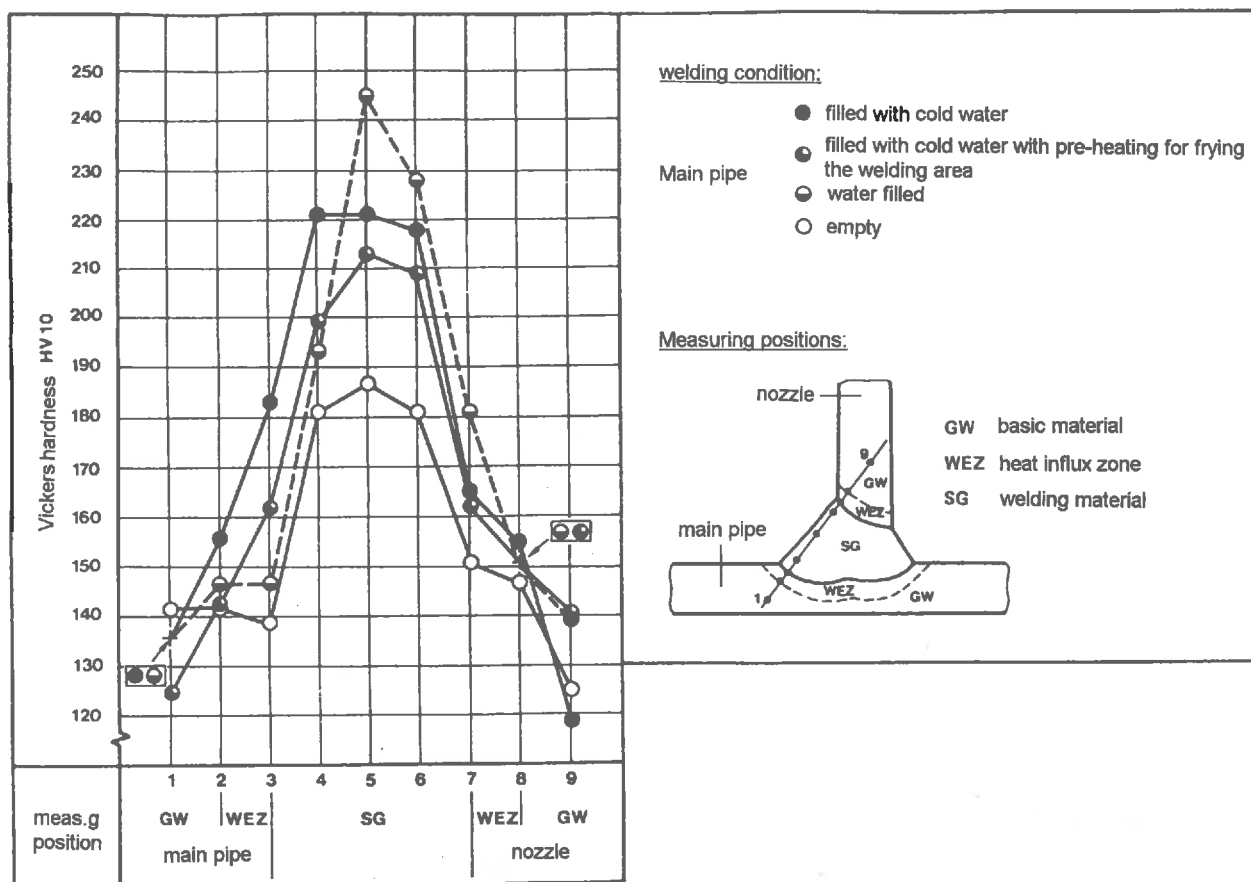

Picture 3-2: Different influences of high heat removal on hardening values at the example of directly welded nozzles [1]

The welding technical judgement was done by the Technischer Überwachungsverein (TÜV) Stuttgart which reached the verdict "that control of the recommended welding ... at the water-filled pipe, welding seam qualities were obtained comparable to ones at empty pipes".

4. Presentation of principle production techniques for manufacturing a pipeline connection without interruption of service

Only such procedures are suitable for the production of a pipeline connection under continuance of heat distribution functioning at operating pressure and at operating temperatures. The drilling-in procedures examined in this work fit this category. The procedure of pipe freezing for example is no part of this, it is carried out at a water-filled pipe but with an interruption of service.

For the production of a branch at a pipeline in operation two technical procedures are offered on the market,

- ◆ The drilling-in and milling drill procedure
- ◆ The shear-off procedure (firing-off),

These procedures are described next.

4.1 The drilling-in and milling drill procedure

The drilling-in and milling drill procedure indicates that the penetration of the pipe wall is carried out with a drill and/or a milling drill. The drilling-in machine must be constructed for this task, so that it can be disassembled at operating pressure after penetrating the pipe wall successfully. This requires the existence of a drain armature which separates the drilling-in machine from the water under pressure.

On the market there are two different constructive solutions of this problem:

One category of drilling-in machines (drilling-in method type A) uses as drain armatures conventional shut-off armatures, in which slide or ball valves fit in best. This procedure is also described as "drilling-in with a lost armature" since the drain armature remains in the branch pipe after the drilling-in.

Another drilling-in machine is so constructed that the drain armature is a component of the drilling-in machine (drilling-in method type B). This drilling-in machine needs special drilling-in T-pieces, through which it is possible to do without a shut-off armature which remains directly at the drilling site. This can be of advantage under cramped space conditions.

Illustration 4-1 shows the differences of the drilling-in procedures described above in a principle diagram. It shows that both types of drilling-in machines are useful for the other procedure. For the drilling-in machine type A use of an drilling-in T-piece is required in addition to a drain armature which can be reused after completing the drilling-in. On the other hand, a drilling-in machine type B may also be used for "drilling-in with a lost armature" if a second armature is used in addition to the equipment as drain armature that remains in the branch pipe.

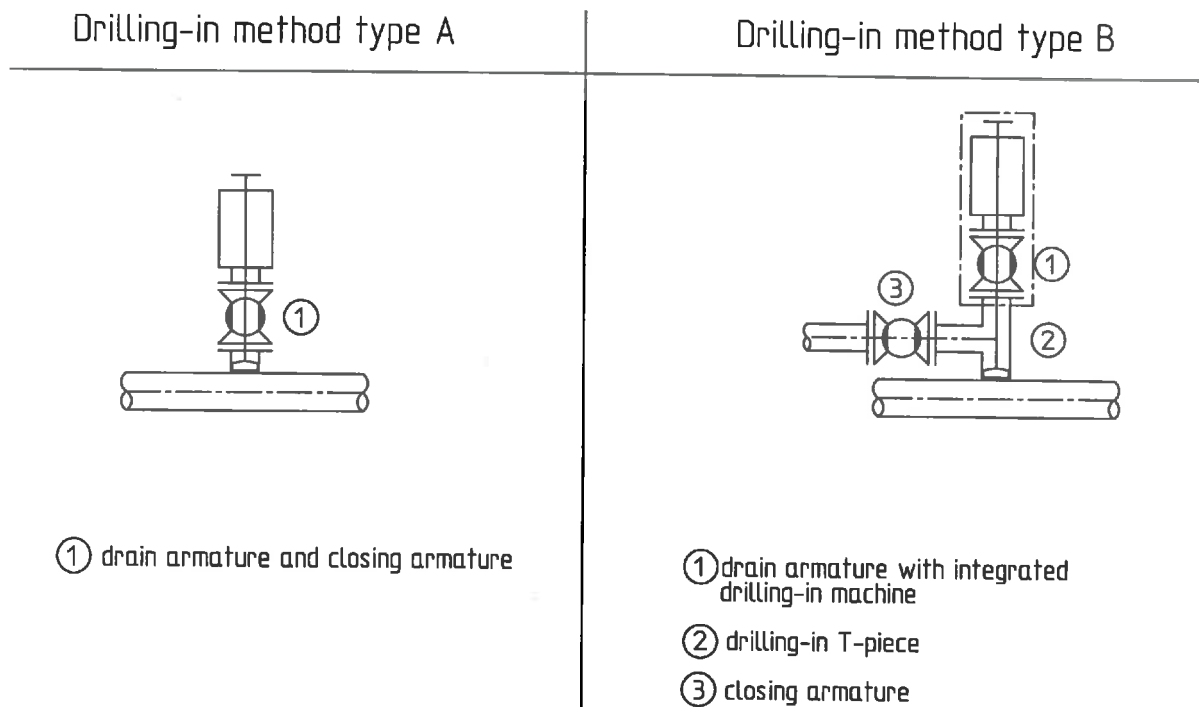

Illustration 4-1: Presentation of the different drilling methods.

The single process steps for a drilling-in are similar for both drilling-in methods and can be described as follows (cf. illustration 4-2):

1. The drilling-in nozzle (drilling-in T-piece (2)) is welded on the de-insulated medium pipeline. The in chapter 2 mentioned requirements on welding to water-filled pipes [1] have to be considered. (At the drilling-in method type B the branch pipeline will now be connected with the drilling-in T-piece.)
- 2./3. The drain armature together with the drilling machine (1) is mounted on the drilling nozzle. The valve is opened and the drilling stick with milling head is fed in. The milling head consists generally of a centre drill and a fret-saw in which the centre drill has the task to lead the milling drill and catch the separated piece of pipe wall.
The centre drill is so constructed that pneumatical as well as electrical drivers can be used as power generator. The following milling of the pipe wall is carried out with the fret-saw.
4. The drilling stick is led back behind the drain armature and the drain armature is closed. (for drilling method type B the opening for the drilling machine gets closed with a special closing piece in the next process step). A pressure equalisation is carried out by the valve in the drilling compartment and remaining cuttings can be rinsed out.
5. The drilling-in machine is dismantled and the separating pipeline attached. The drain armature is opened slowly.

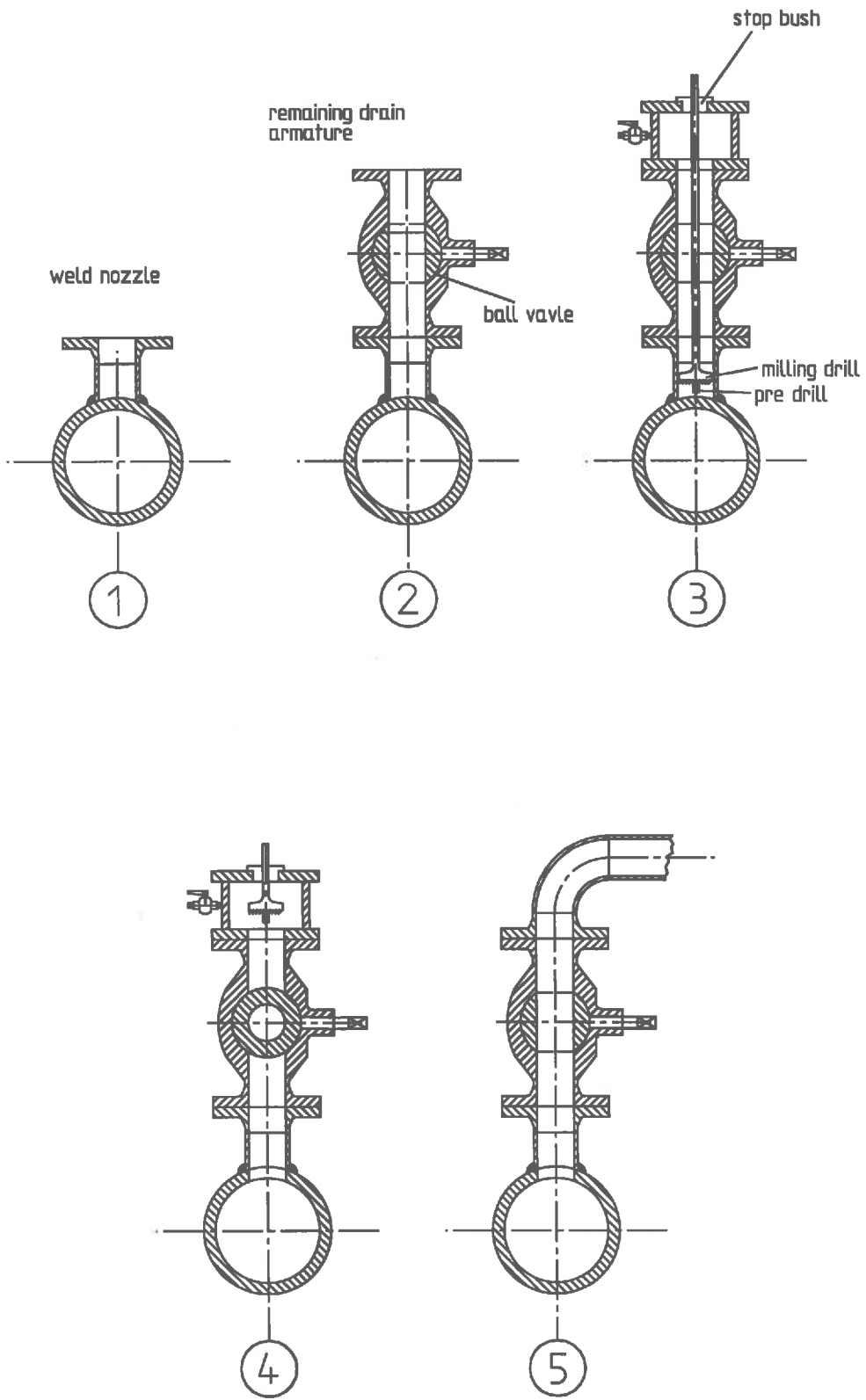

Illustration 4-2: Process steps for the completion of a drilling

4.2 The shear-off procedure (firing-off)

At the shear-off procedure the separation of the pipe wall piece is carried out with an especially constructed cutting club.

The speeding up of the cutting club is realised by the ignition of a propulsive charge by means of hammer blow. The connection of a branch pipeline is relatively simple and fast through this method and there is no need for closing-off or drain armatures.

The single process steps required for the shear-off procedure are presented next (cf. illustration 4-3):

1. The steel cover containing the cutting club and the ignition is welded on the de-insulated main pipe. The requirements on welding to water-filled pipes [1] have to be considered. A special steel cover is required for every combination of dimensions of main and branch pipeline.
2. The branch pipeline is connected.
3. The propulsive charge in the ignition head is activated by a short, firm hammer blow. The cutting club is accelerated by the propulsive charge and a piece of pipe wall will be separated from the rest. The sheared-off pipe wall remains in the distant part of the system-unit cover.
4. The ignition head is removed and the cutting club is turned around slowly 90° . The cutting club is so constructed that after a 90° turn the through flow diameter is fully opened.

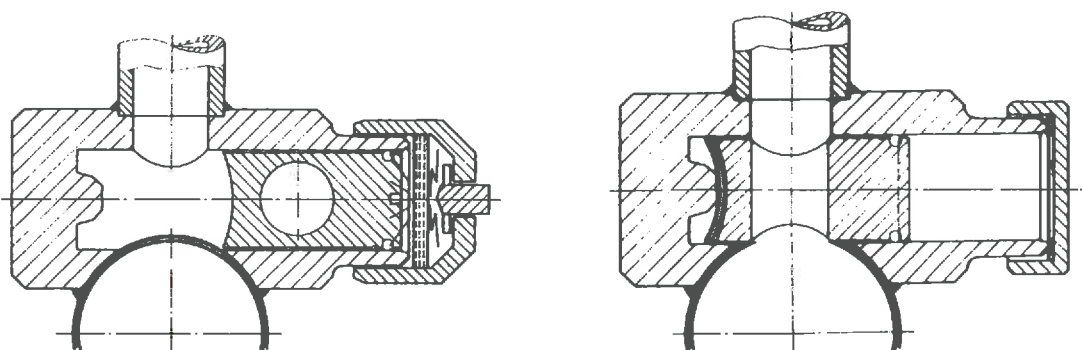

Illustration 4-3: Process steps of the shear-off procedure (firing off) [2]

5. Description of drilling-in machines on the market

In Europe following machine manufacturers are on the market with drilling-in systems according to our market research:

- ♦ TONISCO (Finland)
- ♦ Hütz+Baumgarten (Germany)
- ♦ Walther&partner (Germany)
- ♦ MANIBS (Germany)
- ♦ Pan-Isovit/Flamco-T-plus (Germany)

The drilling-in machines manufactured by TONISCO, Hütz+Baumgarten and Walther&partner have to be assigned to type A according to the principle drilling-in procedure, an additional drain armature is needed as a rule. The manufacturer of MANIBS offers a drilling machine according to the drilling method type B, that works well with a special drilling-in T-piece.

Strictly all drilling-in machines cannot be assigned to one drilling-in method. The drilling-in machines of TONISCO, Hütz+Baumgarten and Walther&partner can also be used for drilling method type B by a corresponding adapter and gadgets. The equipment of MANIBS may be turned around to use it with an additional shut-off armature too, which occurred in drilling-in method type A.

The Flamco-T-plus equipment which is sold by Pan-Isovit is part of the category of shear-off or firing-off machines described in chapter 3.2.

The equipment is described separately with regard to handling in their construction and in their unusual features next.

5.1 TONISCO

TONISCO offers 2 versions of his drilling-in machine:

- TONISCO JR, drilling-in machine for branch dimensions of
DN 25 to DN 100
- TONISCO B40, drilling-in machine for branch dimensions of
DN 125 to DN 400

Construction of drilling-in machine TONISCO JR

Illustration 5-1 shows the construction of the TONISCO JR equipment. It consists of the following components. (The numbers refer to illustration 5-1):

- Drill spindle (1)
- Support unit (2)
- Drill support (3)
- Control valve (4)
- Adapter for connection to drilling-in closure (5)
- Drill container (6)
- Fret-saw (7)
- Centre drill (8)

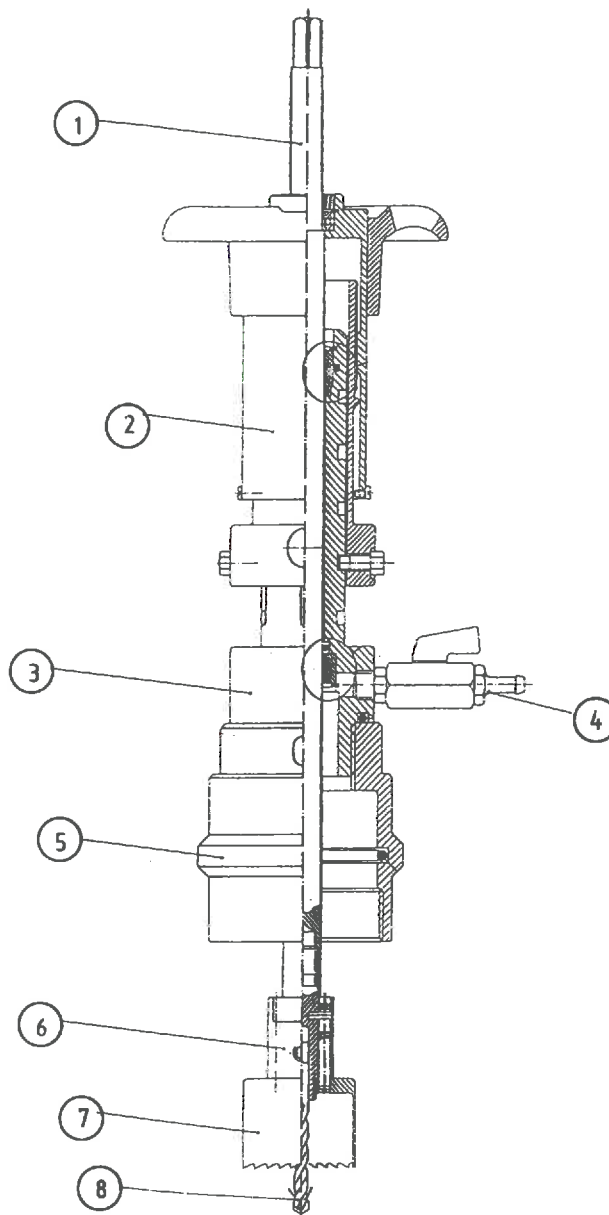
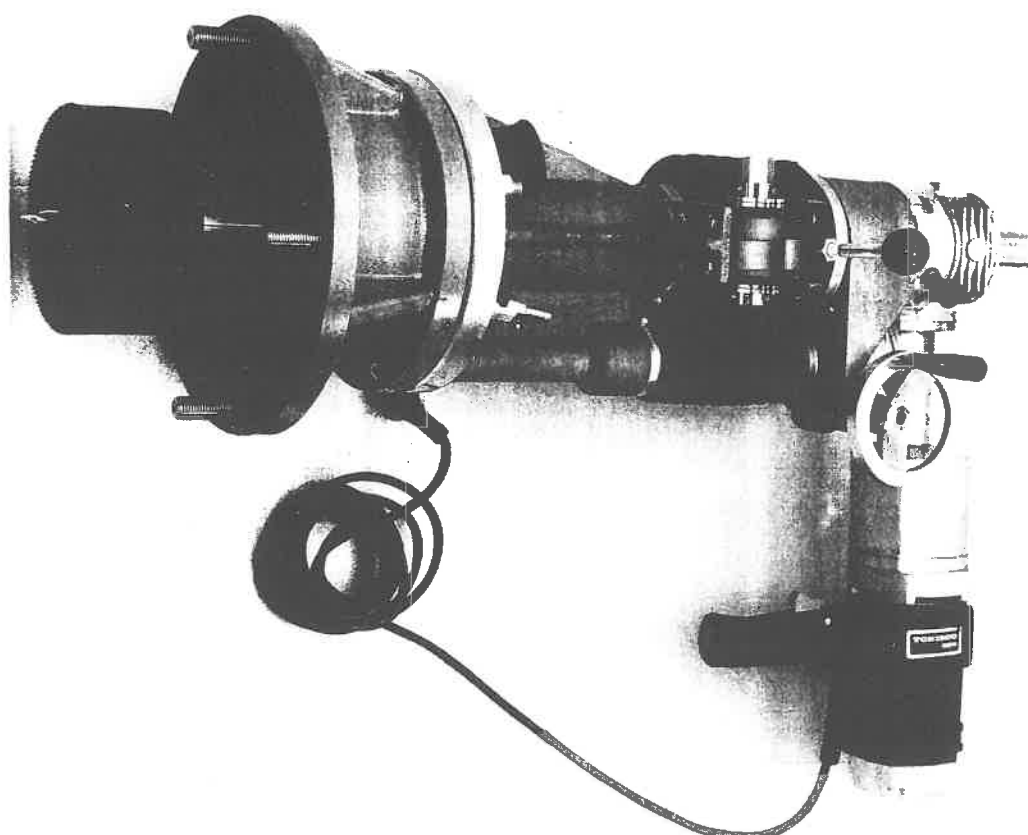

Illustration 5-1: TONISCO JR drilling-in machine

Construction of drilling-in machine TONISCO B40

The drilling-in machine TONISCO B40 is of a construction comparable to the JR. The construction is more stable for higher loads. Illustration 5-2 shows drilling-in machine B40.



Picture 5-2: TONISCO B40 drilling machine

Features of the drilling-in machines of TONISCO

TONISCO offers a drilling-in closure which unites the functions of a drain armature and a welding nozzle together.

This drilling-in closure (cf. illustration 5-3) is provided at one end with a thread of tempered steel to insert the drilling-in machine, the other end gets welded to the main pipeline. The drilling-in closure must be brought in line with the bending of the main pipe under workshop conditions before it gets welded. The drilling-in closure is provided with a slit in which a closing disc can be moved. The closing disc is made of steel, the sealing of the slit is made of synthetic rubber.

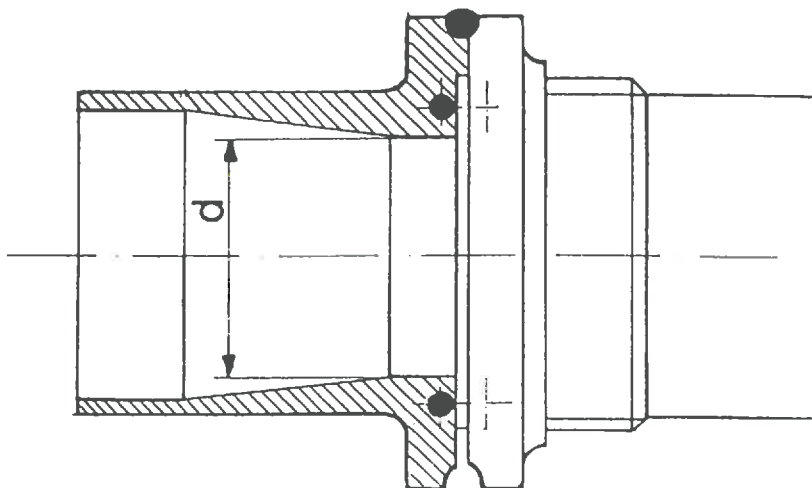

Illustration 5-3: TONISCO drilling-in closure

With the drilling-in closure there appear some interrelated features in the handling of the drilling machine.

The drilling closure must be brought in line with the curvature of the main pipe before welding in the workshop. This has to be done with a grinder. One has to pay attention that the slit for the closing disc does not get dirty.

Attention too for welding the drilling-in closure, it should not get too hot otherwise the sealing could be damaged. The drilling-in closure may have to be cooled. The functionality of the closing disc must be checked after welding. A pressure test of the welding-seam can be realised with the assembled drilling-in machine.

After the drilling the drill head is led back so far that the closing disc can be slid in. The manufacturer recommends that the closing disc is moved in and out when it is un-tight.

While welding the branch pipeline one has to take care that the surface of the closing disc is not damaged by welding spots. The sealing of the drilling-in closure could otherwise be damaged when pulling the closing disc out.

The slit is welded after pulling out the drilling-in closure and is totally closed this way.

5.2 Hütz+Baumgarten

Hütz+Baumgarten manufactures drilling-in machines and armatures in particular for the gas and water distribution. The drilling machine offered by Hütz+Baumgarten is a piece of equipment for district heating modified from the gas application.

The equipment is applicable in the dimensions from DN 50 to DN 100.

Construction of the drilling-in machine of Hütz+Baumgarten

The drilling machine is represented in illustration 5-4 of Hütz+Baumgarten. It consists of the following components (the numbers refer to the illustration 5-4):

- Drilling stand (1)
- Pneumatic drill (2)
- Drilling creaks (3)
- Drilling spindle (4)
- Fret-saw (5)
- Centre drill (6)
- Dome seating (7)
- Remaining shut-off armature (8)

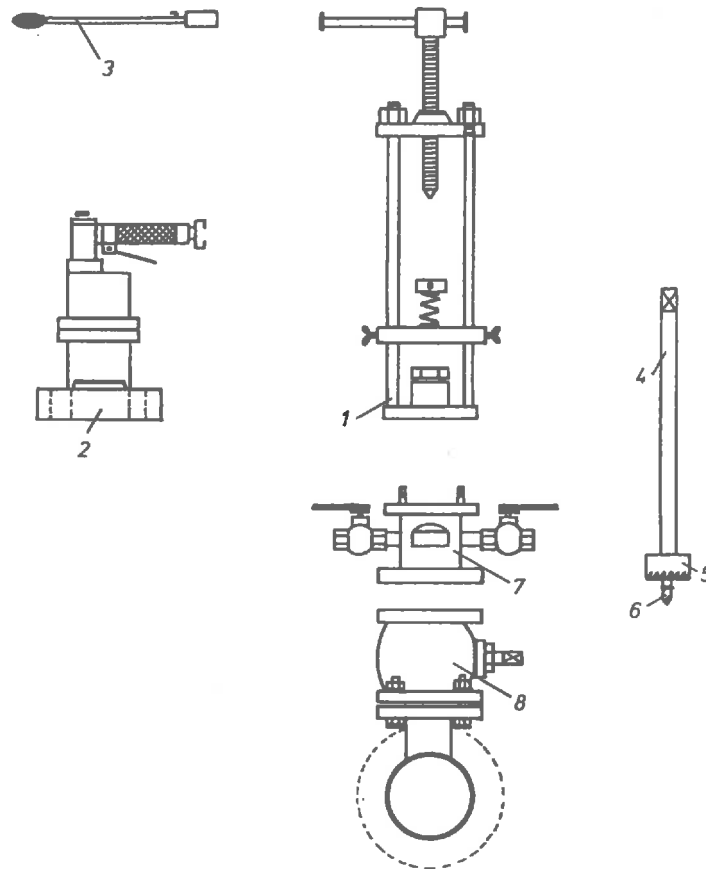

Illustration 5-4: Drilling-in machine for district heating pipelines of Hütz+Baumgarten

Features of the drilling-in machine of Hütz+Baumgarten

For drill sizes of DN 50 to DN 100 the drilling-in machine works according to the principle of the "lost armature" (drilling-in method type A). Every suitable armature can be used as drain and shut-off armature. Pre-requisite is only that the armature can be connected to the dome seating. The dome seating is equipped with a manometer and two ball valve connections which allow for rinsing out cuttings and to pressure test the welding at the filled pipe. There is no special drilling-in nozzle offered by the manufacturer, so that every nozzle can be used that can be connected to the shut-off armature.

For drill sizes DN 32 to DN 50 the drilling-in machine of Hütz+Baumgarten works with an drilling-in T-piece after the drilling-in method type B. A connecting sleeve can be assembled as drain armature to the dome seating and this can be connected by an adapter through a drilling-in T-piece with the drilling-in machine.

The manufacturer offers for the drilling-in machine a pneumatic drive as power generator. This allows for an regular turning speed and makes it possible to drill in by hand. The driller shall be spared by this.

5.3 Walther&Partner

The company Walther&Partner offers 2 versions of its drilling-in machine:

- Drilling machine WP100 for branch dimensions of
DN 40 to DN 100
- Drilling machine WP250 for branch dimensions of
DN 150 to DN 250 (DN 300)

Construction of the drilling-in machines

Illustration 5-5 shows both drilling-in machines. The drilling-in machines consist of the following components:

- Milling drill with support
- Centre drill with magnet
- Electrical power unit
- Pressure gauge and control valve

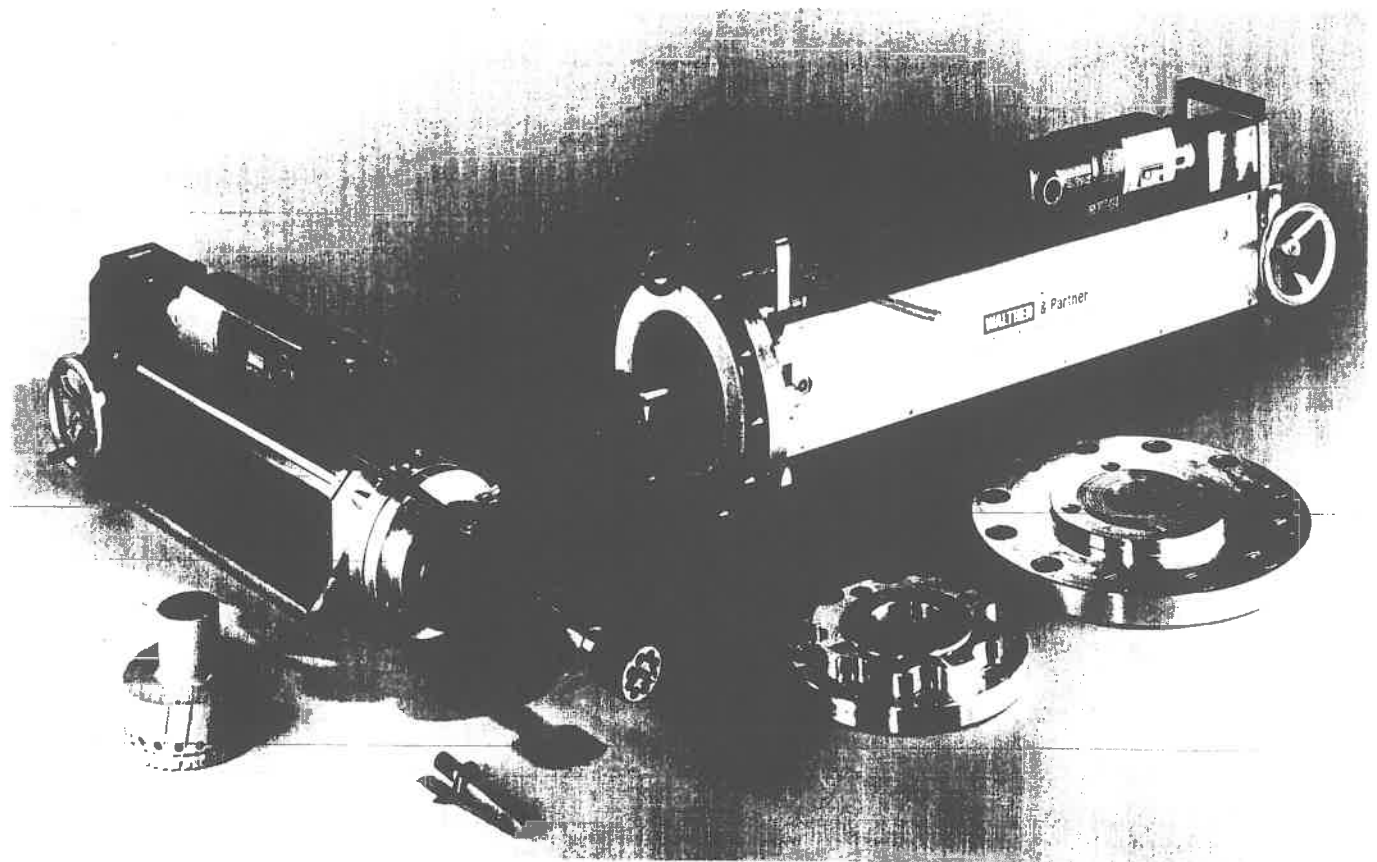

Illustration 5-5: Drilling-in machines WP100 and WP250 of Walther&Partner

Features of the drilling-in system

The drilling-in machines of Walther&Partner have a variety of set-ups for the supply for an exact regulation of the drilling-in/milling drill position. The construction of the equipment is altogether compact and handy.

A magnetic disc is available as collector for cuttings and is assembled in the milling head. For the drilling-in machine are drilling-in closures offered with closing dishes which are comparable to the drilling-in closures of TONISCO.

Here the same remark should be considered for usage of the drilling closures as made for the drilling-in machine of TONISCO. Usually a conventional armature (e.g. ball valve) is used for the drilling-in machine.

5.4 MANIBS

MANIBS offers a drilling-in machine for use with a special drilling-in T-piece (drilling-in method type B). The drilling-in machine is suitable for branch dimensions up to DN 50.

Construction of drilling-in machine

Illustration 5-6 shows the construction of the drilling-in machine. It consists of the following components (numbers refer to illustration 5-6)

- Feeding spindle (1)
- Drill support with 2 traverses (2)
- Drill spindle (3)
- Channels with integrated drain armature (slide valve) and split lock chamber (4)
- Assembly head (5)
- Drill head (6)
- Pneumatic mechanic drive (7)
- Assembly spindle for watertight close (8)
- Watertight close (9)
- Special drilling-in T-pieces (10)



Abb. 5-6: Drilling-in machine of MANIBS

Features of the drilling-in system

The drilling-in machine with integrated sluice can be assembled only on the special drilling-in T piece, so that the drilling-in machine and T-piece must be considered actually as a unity.

Two points shall be stressed with respect to the handling of equipment:

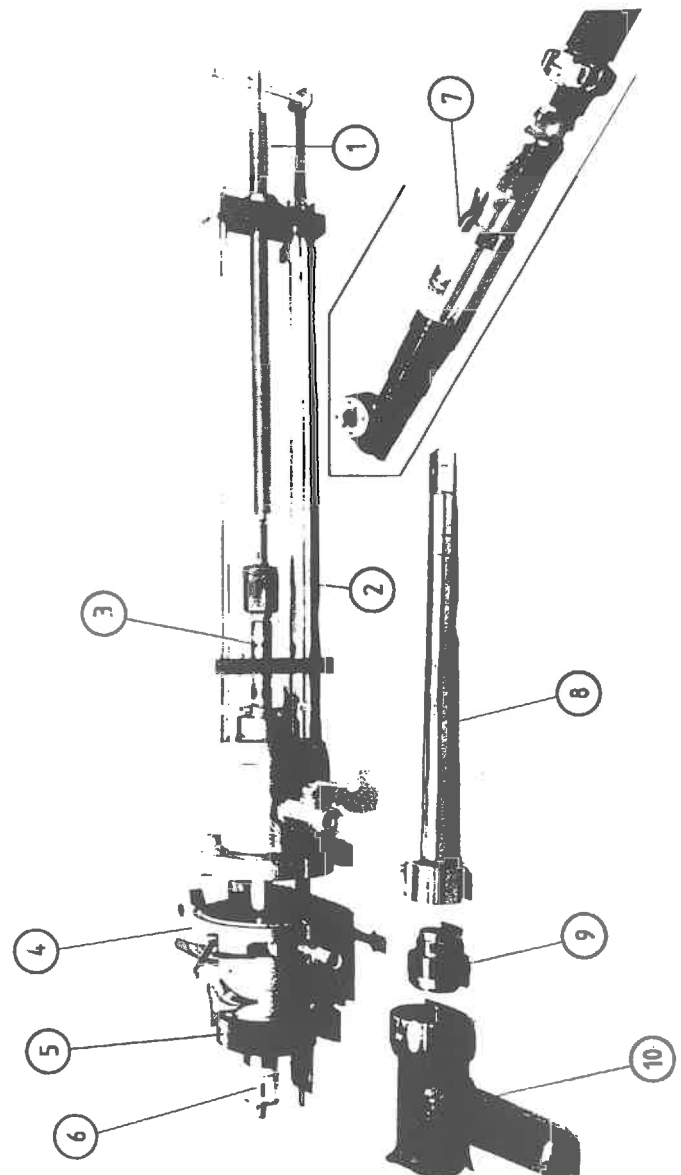
- (a) The equipment is so constructed that to use the drill or the assemble spindle the upper half of the cover of the lock chamber must be lifted off. This solution is very user friendly and makes short assembly runs possible.
- (b) The drilling-in T-piece is so constructed that the upper nozzle is equipped with female thread for turning in the watertight close. Problematic is that while drilling in this pitch of screw thread it is scoured with cuttings that might get caught and prevent the turning in of the watertight close or lead to leaking. Therefore a sealing weld of the watertight close has to be recommended .

5.5 Pan-Isovit/Flamco-T-plus

The Pan-Isovit/Flamco-T-plus system has been a known procedure for many years in plumbing. The use in district heating has been developed from it. For a tight connection of the system-unit cover to the branch pipe a welding construction had to be found. The branch dimension is limited to DN 25 or DN 32.

Construction of the equipment

Illustration 5-7 shows the construction of the Flamco-T-plus firing-off tool (the numbers refer to illustration 5-7):

- (1) Steel cover
- (2) Cutting club
- (3) Ignition head with propulsive charge
- (4) Sealing cover



Abb. 5-7: Firing-off tool Flamco-T-plus

Features of the firing-off system of Flamco-T-plus

The firing-off tool Flamco-T-plus consists of a steel cover which is welded on the pipeline to attach. A special cutting club is led in the system-unit cover, this cuts off exactly the required piece of pipe wall. The cutting club is equipped with a spring washer against axial move and with an O ring to insulate.

The cutting club with an axial drill hole is slid into the system-unit cover and the ignition head with the propulsive charge is turned on. The ignition is activated with a hammer blow and the cutting club clips the pipe wall. With a depth gauge the correct location of the cutting club can be checked. If required the location of the cutting club still can be corrected. The sealing cover locks in a metal closing washer with the system-unit cover.

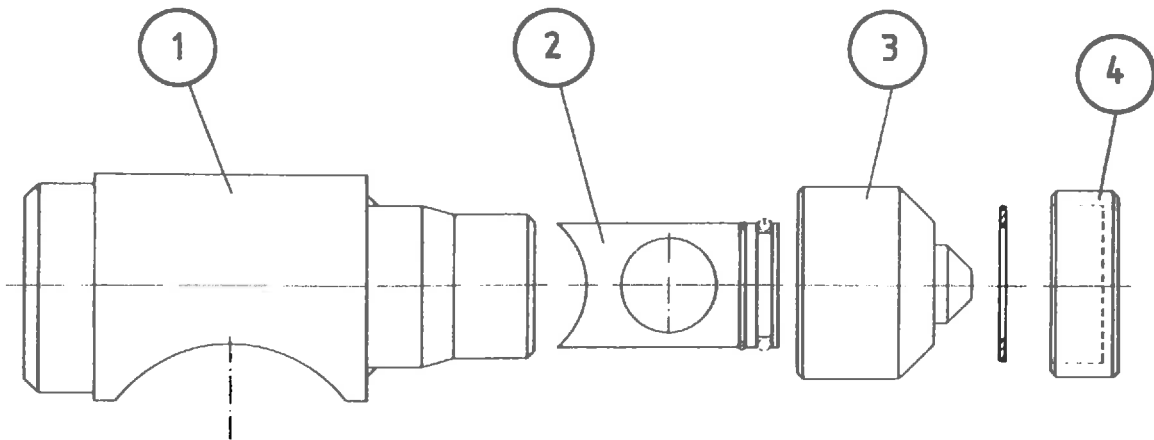
The firing-off system requires a special system-unit cover for every combination of dimensions of a separating pipe to the main pipe. For this the possible number of combinations is restricted.

Realising the connection can be done without cuttings, unlike drilling the armatures. A special sleeves set for the additional heat insulation is offered by the manufacturer, illustration 5-8, this makes insulation afterwards relatively simple.

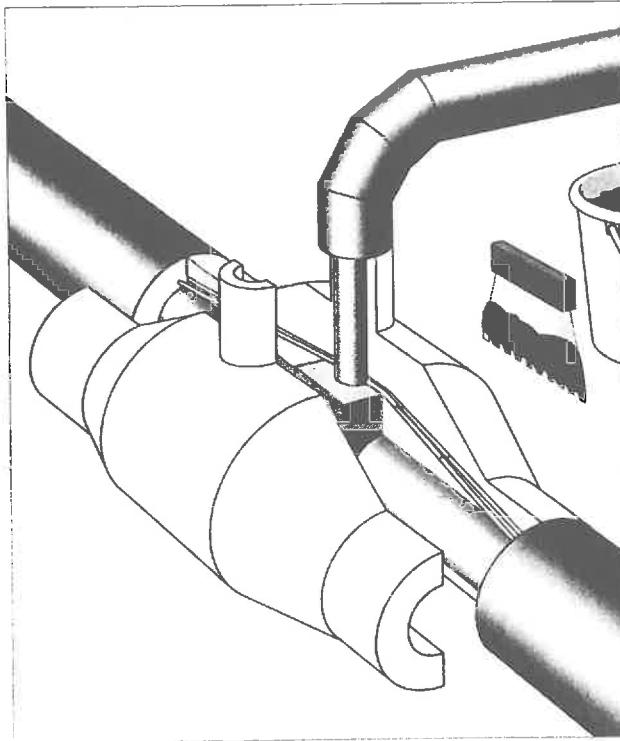

Illustration 5-8: Heat insulation set to the firing-off tool Flamco-T-plus

6. Criteria for the judgement of drilling-in machines

6.1 Opportunities and limitations (temperatures, pressures, drill size)

The drilling-in machines on the market are as a rule prepared for prevailing pressures and temperatures in the field of district heating. The functionality is limited however for constructive reasons mostly. The limitations of the separate drilling-in machines are shown in illustration 6-1 in relation to:

- ◆ Temperature
- ◆ Pressure
- ◆ Drill size
- ◆ Pipe dimensions

drilling-in machine	maximal admissible operation temperature	maximal operation pressure	drilling-in size	size main pipe
TONISCO JR	120 °C	25 bar ¹⁾	DN 25 - DN 100	no limit
TONISCO B40	120 °C	25 bar ¹⁾	DN 125 - DN 400	no limit
Hütz+Baumgarten	110 - 130 °C	20 bar	DN 32 - DN 100	no limit
Walther+Partner WP250	130 °C	25 bar	DN 40 - DN 100	no limit
Walther+Partner WP250	130 °C	25 bar	DN 150 - DN 300	no limit
MANIBS J114	130 °C	25 bar	DN 32 - DN 50	no limit
Flamco T-plus	no limit	no limit	DN 25 - DN 32	DN 32 - DN 80

¹⁾ during the drilling only 10 bar is permitted

Illustration 6-1: Limitations of the drilling-in machines according to details of the manufacturers.

6.2 Handling of the drilling-in machines

6.2.1 Space conditions while drilling-in

A considerable free working space is required to use drilling-in machines for the of connection of a branch. The required working space may roughly be approached by the length of the drill spindle and be indicated by approx. three times the length of the spindle [1]. The drill length corresponds approximately to the distance between the upper side main pipe and upper side drain armature, so that at drill sizes up to approx. DN 100 a free working space of 1,5 to 2 m required is.

For some types of equipment the required working space can be clearly lower. The equipment of MANIBS needs only a clearance of 1 m, it is only suited for drill sizes up to DN 50 though.

For working with equipment with a lost armature the required clearance depends strongly on the construction length of sluice and shut-off armature. As short as possible ball or slide valves are fit for this drilling where the construction length of armatures of different manufacturers partly may differentiate around the factor 2.

The Flamco-T-plus firing-off tool can get by on an minimal required working space so that this equipment has an advantage at sharply cramped conditions.

6.2.2 Pressure test and control during drilling-in

All drilling machines have at least one pressure connection, usually with a handle, where the fitting point as a rule is above drain armature. Before and during the drilling the pressure connection can fulfil several functions:

Before the drilling a pressure test of the welding-seam of the branch nozzle can be carried out at an attached drilling set.

A permanent pressure control is possible during the drilling by means of a manometer so that the breaking through of the drill in the wall of the main pipeline can be noticed with the rise in pressure.

Before drilling a pressure may be generated inside the drilling set and can be used to check the welding and prevent a sudden high load on the drill spindle when the pipe wall breaks.

Additionally there is the possibility to rinse out under pressure the cuttings generated while drilling.

6.2.3 Drill and milling drill

All drilling-in machine manufacturers offer a combination of pre-drill (centre drill) and milling drill as drilling head. The pre-drill has to accomplish two tasks:

- ◆ The pre-drill shall centre the drill and lead the milling drill.
- ◆ As a rule the pre-drill is equipped for catching the separated pipe wall disc with a device. Pre-drills with a spring washer under a nut are very well equipped for that.

The milling drill realises the real cutting through of the pipe surface. Due to the surface curvature of the pipe the teeth of the milling drill are partly intruding at the beginning of the drilling session very strong load differences work at uneven progress.

Fret-saws have shown themselves as particularly favourable. They are very good value for money and due to their smaller cutting planes there is less power needed which means a lower wear out. It also appears that fret-saws have less milling dust. However harder materials must be used for fret-saws drill sizes larger than DN 150 so that the price advantage disappears.

6.2.4 Removal of cuttings

Depending on the construction and the size of the milling drill and the pre drilling a considerable cuttings are left. The steel part can be up to 70 % of the drill mass [1].

Which consequence this left cuttings has on the capability and functionality of the network and of the following armatures, pumps and heat exchanger there is no secured knowledge available at present. The entry of steel cuttings into the network should be avoided. Following methods are used to remove steel cuttings:

- ◆ Rinsing out cuttings

During and after the drilling created cuttings can be rinsed out over the pressure connection at the drilling-in machine. The success of the rinse out depends on the flow conditions at the drilling site and the course of outflow.

- ◆ Magnetic dishes to catch the cuttings

Two manufacturers (MANIBS and Walther&Partner) offer magnetic dishes to catch the cuttings which is attached in the milling head in the shape of a round disc. This magnetic disc catches as well the cut out pipe wall as the cuttings. After the drilling the magnetic disc can also catch the cuttings and dust which sunk to the bottom of the pipe.

The share of the cuttings was examined in a series of experiments [1]. At different conditions strongly changing results were achieved which are partly not explicable. The result was between 3 % and 73 %. A great share of the available cuttings can under favourable conditions be removed.

7 Aspects of technical safety

Doubts on the safety of the drilling-in technology was the cause that it was not practised frequently. Therefore the Arbeitsgemeinschaft Fernwärme e.V. (AGFW) in Germany prepared a guideline in which the considerable technical safety requirements for drilling are presented [3]. A new version of this guideline is being reworked at the moment.

7.1 Safety of the connecting construction and the drilling-in machine

The connecting construction consists of a main pipe, a branch pipe and a branch nozzle which must be laid out correctly for sufficient safety with the appearing loads. A minimum value must be set at this moment for the wall thickness of the main pipeline in the area of the drilling. Appendix B shows results for the minimum strength of walls calculated according to AD-sheet B9 [3] (AD = Arbeitsgemeinschaft Druckbehälter). A load has been attached only to the inner over-pressure. At additionally submitted loads, e.g. due to temperature restricted expansion of the pipeline (particularly large at cold laying) the required wall strength has to be proved. A reinforcement of the main pipe by strengthening rings is then frequently required.

For a perfect welding the drilling-in nozzle of dimensions to DN 50 must be carefully prepared and brought into line with the curvature of the pipe wall radius. For larger branch dimensions customisation can be dropped.

The guideline of the AGFW [3] prescribes secure functional safety of the drilling-in machines that only admitted equipment may be used for the execution of drilling-in at the building site. At the moment however it is not yet decided upon whether such a permission is required for every single piece of equipment or whether a working permission is not granted for drilling-in machines in general if the technological risks as e.g. leakages of the closing disc, welding seam quality etc. is minimised by corresponding regulations. The new draft of the AGFW guideline for drilling-in which will fix the work permission of the drilling machines was not yet ready at the time of the finishing of this report.

Expert remarks to the safety of drilling-in procedures due to unclear requirements of the manufacturers MANIBS and TONISCO are produced earlier. Computer tests and tests of stability and consistence were carried out. The examinations yielded no doubts based on technological safety at both pieces of equipment. But the remark is made at the TONISCO equipment though that "a little of the medium can come out for a short time when sliding in or removing the closing disc". Needed are special safety measures.

7.3 Job safety at the drilling-in

To prevent endangering of the employees at the drilling-in one shall stick to the following rules :

- ◆ The space conditions on the spot must allow the easy use of the drilling equipment. To consider are guidelines of the trade organisations ZH 1/77, "Richtlinien für Arbeiten in Behältern und engen Räumen", and ZH 1/110, "Sicherheitsregeln für den Betrieb von Fernwärmenetzen".
- ◆ Welding and drilling may only be carried out by people who are trained particularly to become familiar with the working of the drilling machine.
- ◆ A job specification must point out clearly all remarks with relevance to security. Any use of special welding procedures and sort of electrodes should be clearly stated.
- ◆ No special safety clothing is required for this kind of drilling. For welding it is sufficient to use the usual safety gear of an electric welder (UVV VGB 15).
- ◆ At the execution of the drilling-in the following checks have to be performed:
 1. Sound functional condition of the drilling machine (examine the sealings e.g.)
 2. Perfect assembly of the equipment
 3. Test of welded nozzle and assembled drilling machine
 4. Draining off leaving drilling water
 5. Secure for closing valve for unwanted opening after the drillings.

The AGFW guideline recommends to have a job protocol for every drilling-in in which all essential data and tests are documented. Appendix C shows an example for such a guideline.

8. Comparison of costs

A comparison of costs was carried out for the different drilling machines in the context of this work with regard to

- ◆ Investment costs for the acquisition of a drilling-in machine,
- ◆ Costs for the production of a connection.

8.1 Investment costs

The manufacturers of drilling-in machines were asked to give list prices for the acquisition of their equipment including accessories. The prices are presented in illustration 8-1 (all details in DM), price level 1994. The list contains accessories required for the use of the drilling machine incl. adapter and tools. Costs for separate drain armatures are not included. All prices are net-prices.

The investment costs for drilling-in machines cannot be compared with each other directly since the pieces of equipment cover different dimension areas for drilling. That the TONISCO JR piece of equipment is offered very favourably nevertheless is conspicuous.

8.2 Comparison of costs of drilling-in systems for realisation of a connection

In the following chapters the costs for the production of a connection without service interruption of single drilling-in machines were estimated and compared. The cost of drilling-in was investigated for three combinations of a branch connection to a main pipe, for

	Main pipe	/	Branch pipe
-	DN 400	/	DN 100
-	DN 150	/	DN 65
-	DN 65	/	DN 32.

The determined costs have to be understood as comparative costs, that is merely such costs were included which differ at different drilling-in systems. It is assumed, that the distribution company buys a drilling machine and carries out the drilling with their own staff. The costs are investigated for the supply line and for the return line.

TONISCO JR (DN 25 - DN 100)	TONISCO B40 (DN 100 - DN 400)	Hütz + Baumgarten (DN 32 - DN 100)	Walther & Part. WP 100 (DN 40 - DN 100)	Walther & Part. WP 250 (DN 100 bis DN 250)	MANIBS J114 (DN 40 - DN 50)	Pan-Isovit/Flamco-T-Plus
drilling-in set incl. electr. driver	drilling-in set incl. electr. driver	drill stand	drilling-in set incl. electr. driver	drilling-in set incl. electr. driver	drilling-in set inclusive drill rattle	firing-off set
3.654,30	13.887,30	pneumatic drill	8.950,--	12.400,--	7.157,80	main pipe / branch
adapter for drill closure (DN 25- DN 100)	adapter for drilling-in (DN 100 - DN 400)	transport case	1.350,--	2.380,--	146,40	DN 32/ DN 25-32
1.247,70	8.489,--	drilling spindle	900,--	6.764,--	adapter	DN 40/ DN 25-32
hole saw + centre drill (2 per dimension)	hole saw + centre drill (2 per dimension)	dome seating	315,--	540,--	fret saw (2 per dimension)	DN 50/ DN 25-32
564,20	15.833,80	nozzle shift	216,--	368,--	centre drill (per 2)	DN 65/ DN 25-32
closing dish (2 per dimension)	closing dish (2 per dimension)	adapter T-peace (DN 32-DN50)	8.950,--	368,--	magnet (DN 40, DN 50)	DN 80/ DN 25-32
530,80	2.496,--	bush spindle	1.350,--	368,--	200,--	940,--
handle		spiral drill (per 2)	1.350,--	368,--	33,40	
		milling drill DN 40 (per 2)	1.350,--	368,--	252,60	
		centre drill (per 2)	1.350,--	368,--		
		drill spindle	1.350,--	368,--		
		milling drill + centre drill (2 per dimension)	1.350,--	368,--		
		intermediate (DN 50 - DN 100)	1.350,--	368,--		
		transport case	1.350,--	368,--		
		Total	11.731,--	22.452,--	Total	Total
Total	40.706,10	19.388,88	11.731,--	22.452,--	7.790,20	3.946,-

Illustration 8-1: Investment costs for drilling-in equipment inclusive accessories (DM price level 1994, no VAT)

Considered are:

- ◆ Labour for preparing and guiding the drilling. To the prepare the work the drilling-in nozzle should be aligned with the curvature of the main pipe. Labour is calculated at 70,- DM/h.
- ◆ Material costs for the drillings, e.g. the costs for the remaining drain armature or drilling-in closure and for the welding nozzle.
- ◆ Cost of capital for the investments for the drilling-in machine including accessories (cf. illustration 8.1). The cost of capital is determined by an interest rate of 8 % and a 10 years life time of the drilling-in machine. To determine the costs per drilling it is assumed that the number of drillings per annum is 15.
- ◆ Assembly and material costs for the insulation after the drilling has been done.

Not considered is:

- ◆ Finishing insulation of the main pipe
- ◆ Costs for welding the drilling-in nozzle on the main pipe.

At these costs is pre-supposed that they are identical for a combination of dimensions at all drilling systems.

The following costs result for the production of a connection for a supply and return pipeline (illustration 8-2):

main pipe / branch pipe [DN/DN]	TONISCO		Hütiz + Baumgarten		Walther & Partner		MANBIS ** 65/32	Flamco-T-Plus 65/32
	400/100	150/65	400/100	150/65	400/100	150/65		
capital cost drilling-in system	60,- DM	60,- DM	190,- DM	190,- DM	120,- DM	120,- DM	165,- DM	-
material cost	720,- DM	470,- DM	1.360,- DM	520,- DM	1.360,- DM	520,- DM	-	1.795,- DM
	-	-	100,- DM	50,- DM	100,- DM	150,- DM	220,- DM	-
time consumption	2,5 h	2,5 h	2,5 h	2,5 h	2,5 h	2,5 h	2 h	0,75 h
labour cost	175,- DM	175,- DM	175,- DM	175,- DM	175,- DM	175,- DM	140,- DM	50,- DM
re-insulation	1.900,- DM	860,- DM	1.900,- DM	860,- DM	1.900,- DM	860,- DM	710,- DM	980,- DM
Total	2.855,- DM	1.565,- DM	3.725,- DM	1.795,- DM	3.655,- DM (2.920,-DM*)	1.725,- DM (1.645,-DM*)	1.235,- DM	2.825,- DM

in case of a drilling-in bush

assumption of 7 drillings per year

Illustration 8-2: Costs of the creation of a branch pipe (supply and return line) without interruption of supply

The drilling-in system TONISCO is the less expensive system in the comparison, for the low purchase costs and the low material costs for the TONISCO drilling closure. For the same reason comparatively high costs arise at the systems of Hütz+Baumgarten and Walther&Partner because ball valves at their equipment are more expensive as drain armatures than drilling-in closures. The disadvantages mentioned already of the drilling-in closures have to be considered.

The firing off system with the Flamco-T-Plus-System proves to be most expensive. Reason for this is a comparatively high price for the firing-off tool which can be used for only one drilling-in. Also the corresponding insulation costs must clearly be calculated higher than at the other systems. The advantages of the system is the fast and simple handling and the need for little working space. This system will be more favourable at specific uses and at a low number of drilling-ins per year.

For the sake of completeness should be stated that the manufacturers TONISCO and Walther&Partner also offer a drilling-in service. In Appendix D the prices are presented of the performances offered by TONISCO in Germany.

9. Acknowledgements

- [1] TWS Stuttgart: "Schweißen an wassergefüllten Rohren für das Anbohren und Reparieren von Fernwärmeleitungen"
Abschlußbericht Januar 1985
- [2] Schindler, R.; Trinkmann, R.: "Herstellen von Abgängen für Hausanschlußleitungen an in Betrieb befindlichen Verteilerleitungen"
FWI, Jg 20 (1991), S. 208 - 211
- [3] AGFW-Merkblatt 6.2: "Herstellen eines Rohrabzweiges an in Betrieb befindlichen Fernwärmeleitungen nach dem Anbohrverfahren"

Appendix A

- 1 TONISCO SYSTEM OY
Tarjankatu 1
33100 Tampere
Finnland

- 2 Hütz + Baumgarten GmbH & Co KG
Solingerstraße 23-25
42857 Remscheid
Deutschland

- 3 Walther & Partner GmbH
Marzahner Chausse 227
12681 Berlin
Deutschland

- 4 MANBIS GmbH & Co KG
Lempstraße 24
42859 Remscheid
Deutschland

- 5 Pan-Isovit GmbH
Siemensstraße 18
67346 Speyer
Deutschland

Appendix B

Main pipe		minimal and maximal wall thickness of branch nozzle							
DN	Da	Sa	DN	50	65	80	100	125	150
				60.3	76.1	88.9	114.3	139.7	168.3
65	76.1	2.9	min. max.	2.9 5.6					
80	88.9	3.2	min. max.	2.9 6.3	2.9 6.3				
100	114.3	3.6	min. max.	2.9 6.3	2.9 7.1	3.2 7.1			
125	139.7	3.6	min. max.	2.9 6.3	2.9 7.1	3.2 7.1	3.6 6.3		
150	168.3	4.0	min. max.	2.9 7.1	2.9 7.1	3.2 8.0	3.6 7.1	3.6 7.1	
200	219.1	4.5	min. max.	2.9 7.1	2.9 8.0	3.2 8.0	3.6 8.0	3.6 8.0	4.0 8.0
250	273.0	5.0	min. max.	2.9 7.1	2.9 8.0	3.2 8.8	3.6 8.8	3.6 8.8	4.0 8.8
300	323.9	5.6	min. max.	2.9 8.0	2.9 8.8	3.2 8.8	3.6 8.8	3.6 1.0	4.0 11.0
350	355.6	6.3	min. max.	2.9 8.0	2.9 8.8	3.2 10.0	3.6 10.0	3.6 11.0	4.0 11.0
400	406.4	6.3	min. max.	2.9 8.0	2.9 8.8	3.2 10.0	3.6 10.0	3.6 11.0	4.0 11.0
450	457.2	6.3	min. max.	2.9 7.1	2.9 8.8	3.2 10.0	3.6 10.0	3.6 10.0	4.0 11.0
500	508.0	7.1	min. max.	2.9 8.0	2.9 8.8	3.2 10.0	3.6 11.0	3.6 11.0	4.0 12.5
600	609.6	8.8	min. max.	2.9 8.8	2.9 10.0	3.2 11.0	3.6 12.5	3.6 12.5	4.0 14.2
700	711.2	10.0	min. max.	2.9 10.0	2.9 11.0	3.2 11.0	3.6 12.5	3.6 14.2	4.0 14.2
800	812.8	11.0	min. max.	2.9 11.0	2.9 11.0	3.2 12.5	3.6 12.5	3.6 14.2	4.0 16.0

Da = outside dimension for main pipe and branch (mm)
 SA = minimal wall thickness main pipe (mm); (smaller values need a static approval)

Computing basics:

Calculations according to AD-sheet B9 - load based on inside over-pressure
 Material St 35 or St 37
 Temperature: 150 °C, PN 16

c₁ = complement for walls falling short, according DIN 1626 respectively. 1629
 c₂ = complement for corrosion is set at "0"

Up to DN 100 seamless pipes were used according to DIN 2458, from DN 125 welded pipes according to DIN 2448 (welding seam factor 0.9) were presupposed

Minimal wall thickness for branch pipes (pipe at pipe) according AD-sheet B9 [3]

Appendix C

Example for guideline

Guideline for the connection of a branch pipe by drilling-in

Place of drilling-in:

Date of drilling-in:

1. Preparation

DN supply line:

Wall thickness: mm

Approved by: US measurement Work file

DN return line:

Wall thickness: mm

Approved by: US measurement Work file

Supply drilling-in nozzle DN Type:

Return drilling-in nozzle DN Type:

Operation with drilling in equipment Type:

Welding created with electrodes

and welding procedure

Local circumstances allow welding and perfect assembly as well as operation

of the drilling-in equipment YES NO

Signature of the person in charge:

Date:

2. Realisation

Person accountable for welding: _____

Person accountable for drilling-in: _____

2.1 Welding seam is regularly created and tested. (test medium air)

YES

2.2 Drilling-in is executed without objection.

YES NO

Clearance of working site for further operation.

YES NO

Signature of person accountable:

Date

Remarks: _____

Appendix D

Drilling-in service of TONISCO

Offer to execute branch pipes under pressure (District Heating pipelines)

Now the opportunity is available for you to order us for your drilling-in activities . We offer you our drilling-in service with our closures. The job is realised according the requirements and specifications of the principal.

Work process

Our people will execute the drilling-in under pressure at the spot determined by the principle. The components for the connection, closures, are welded to the pipeline by the principle. The welding and the adjustments are should be realised before to allow for a fast connecting job. In case of difficult local conditions we are prepared to provide instructions concerning connecting job and preparations for the connection.

The welding may also be realised by our people. Normally they are no experts at welding so we have to ask you to get to an agreement in advance if we must order for them. The principle takes care of the safety of the surrounding and construction of possibly necessary installations.

All our branch components are applicable up to a pressure of PN 25. At drilling-in closure > DN 100 the operating pressure must be reduced to 10 bar to prevent damaging the closing disc. When the drilling-in is finished and the branch pipeline has been welded to the closure and filled, the operating pressure may again be raised up to 25 bar.

The connecting job should be ordered as early as possible to execute all the necessary preparations. Normal lead time is 4 weeks. If possible we will try to realise a shorter lead time but for planning of the connecting job the normal lead time is the safe option.

Price

The pricing is based on labour time and cost compensation. Working time starts when the worker leaves the office in Steyerberg, D-31595, and finishes by returning at the office. When preparation is included which must be executed at our work they will be invoiced as starting cost. Travelling time, travelling kilometres and hotel expenses, and the waiting at the building site are calculated as specified.

BASIC PRICE FOR DRILLING-INS

The price contains the prices for the closures and compensation for the use of the connecting equipment.

Branch 2 * DN 25	DM	374,00
Branch 2 * DN 32	DM	417,00
Branch 2 * DN 40	DM	478,00
Branch 2 * DN 65	DM	530,00
Branch 2 * DN 80	DM	648,00
Branch 2 * DN 100	DM	803,00
Branch 2 * DN 125	DM	948,00
Branch 2 * DN 150	DM	1.154,00
Branch 2 * DN 200	DM	1.409,00
Branch 2 * DN 250	DM	2.660,00
Branch 2 * DN 300	DM	3.781,00
Branch 2 * DN 350	DM	4.690,00
Branch 2 * DN 400	DM	6.648,00

Starting costs and time compensation have to be added to the prices:

Starting cost	DM	260,00 per order
Compensation for time travelling, working, waiting	DM	70,00 per person per hour

Compensation for travelling (from Steyerberg) and the hotel expenses etc.

Call money depending on length of labour day:

< 8 hours	1/2 call money	DM	45,20 per person per day
> 8 hours	1/1 call money	DM	85,00 per person per day

Compensation for hotel expenses

for staying overnight at the job	DM	130,00 per person per night
compensation for travelling	DM	0,60 per km

Branches > DN 100 need normally two workers.

Pricing example:

1 * drilling-in 2 * DN 100	DM	948,00
1 * starting costs	DM	260,00
Compensation travelling (2 * 230 km) 6.0 hours		
Compensation labour		
1.5 hours		
7.5 hours at DM 66,00	DM	495,00
Call money 1 person	DM	42,50
compensation km		
660 km at DM 0,60	DM	396,00
Total	DM	<u>2.141,00</u>

IEA District Heating and Cooling

EXECUTION OF CONNECTIONS TO PIPELINES IN OPERATION

Published by
Netherlands Agency for Energy and the Environment

Mailing address: P.O.Box 17, 6130 AA Sittard, the Netherlands
Street address: Swentiboldstraat 21, Sittard
Telephone: +31 46 4595295
Telefax: +31 46 4528260

1996: N 3.3
ISBN 90-72130-82-0